

REMER

RUBINETTERIE

SERIE
SERIES

COLONNE DOCCIA

SHOWER COLUMNS

EQ32X7SDSD20

CODICE
CODE

IMMAGINE - IMAGE



SCHEMA TECNICA - TECHNICAL FEATURES

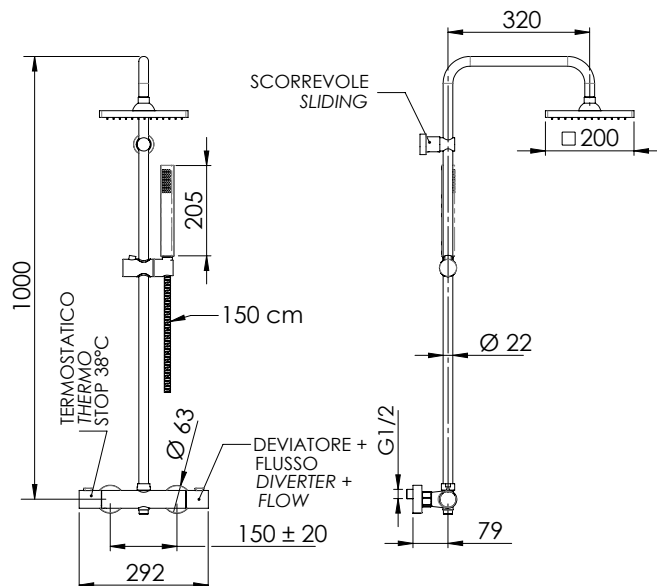

DESCRIZIONE - DESCRIPTION

Set doccia composto da: miscelatore termostatico esterno con deviatore incorporato (EQ32); soffione quadrato 20x20 cm in abs cromato, con getti in silicone anticalcare (356SD20X); colonna con fissaggio superiore regolabile in altezza (329X); doccetta quadrata in ABS cromato con getti in silicone, 1 funzione (317SD); flessibile 150 cm.

Shower set including: exposed thermostatic mixer with integrated diverter (EQ32); square shower head 20x20 cm in c.p. abs, with anti-limescale silicone jets (356SD20X); shower column with height-adjustable top fixing (329X); 1-function square handshower in c.p. abs with anti-limescale jets (317SD); 150 cm flexible hose.

CARATTERISTICHE - FEATURES



2 Vie
2 Ways



Termostatico
Thermostatic



Getto effetto pioggia ad ampia copertura
Wide coverage rain effect



Flessibile Lungo 150 cm
Flexible Length 150 cm



Con Getti Anticalcare
With Antilimescale Jets



Getto vigoroso effetto pioggia
Vigorous rain effect jet

COMPONENTI - COMPONENTS



Cartuccia E50P
Cartridge E50P



Cartuccia H50
Cartridge H50

FINITURE - FINISHING



CR
Cromo
Chrome

REMER Rubinetterie S.p.A.

Via Leonardo Da Vinci, 83 - 20062 Cassano d'Adda (MI) - Italy - Tel. +39 0363 364211 - info@remer.eu - www.remer.eu