

REMER

RUBINETTERIE

SERIE
SERIES

CLASS LINE

CODICE
CODE

L10L

IMMAGINE - IMAGE



SCHEMA TECNICA - TECHNICAL FEATURES

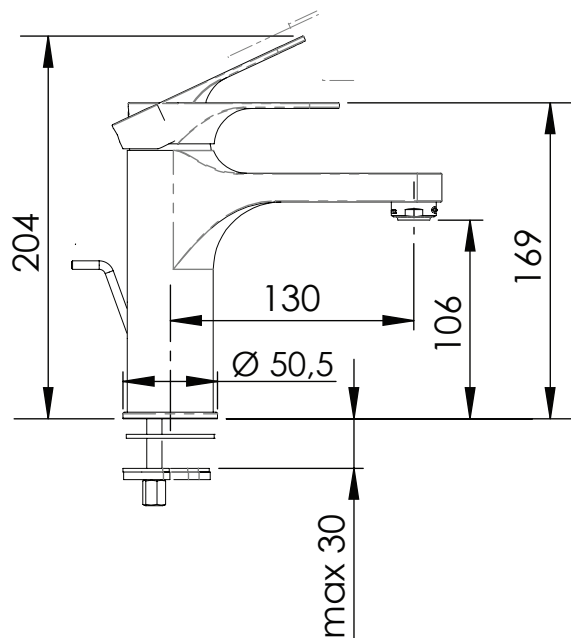

DESCRIZIONE - DESCRIPTION

Miscelatore monocomando lavabo alto L, con scarico.

L high single lever basin mixer, with pop-up waste.

CARATTERISTICHE - FEATURES



Disponibile in Finitura
Available in Finishing



Perfect Tune
Perfect Tune



Con scarico
With pop-up waste

COMPONENTI - COMPONENTS



Cartuccia R50
Cartridge R50



Aeratore 83NESI
Aerator 83NESI

REMER Rubinetterie S.p.A.

Via Leonardo Da Vinci, 83 - 20062 Cassano d'Adda (MI) - Italy - Tel. +39 0363 364211 - info@remer.eu - www.remer.eu