

# REMER

RUBINETTERIE

SERIE  
SERIES

## CLASS LINE

CODICE  
CODE

## L10

### IMMAGINE - IMAGE



### SCHEMA TECNICA - TECHNICAL FEATURES

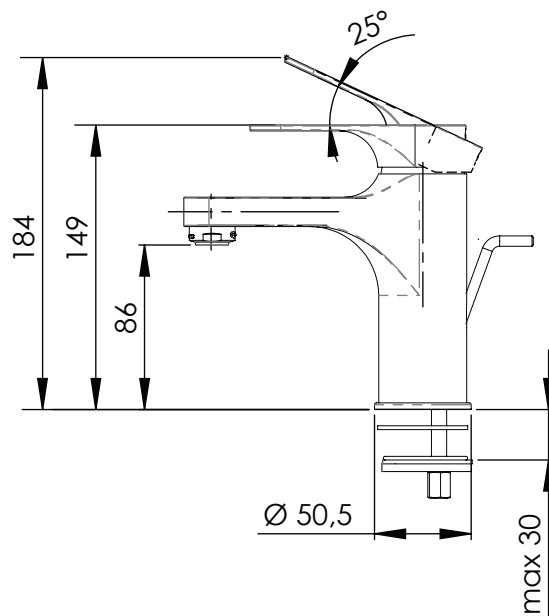

### DESCRIZIONE - DESCRIPTION

Miscelatore monocomando lavabo con scarico.

Single-lever basin mixer with pop-up waste.

### CARATTERISTICHE - FEATURES



Disponibile in Finitura  
Available in Finishing



Perfect Tune  
Perfect Tune



Con scarico  
With pop-up waste

### COMPONENTI - COMPONENTS



Cartuccia R50  
Cartridge R50



Aeratore 83NESI  
Aerator 83NESI

REMER Rubinetterie S.p.A.

Via Leonardo Da Vinci, 83 - 20062 Cassano d'Adda (MI) - Italy - Tel. +39 0363 364211 - info@remer.eu - www.remer.eu