

REMER

SCHEDA TECNICA

TECHNICAL FEATURES

RUBINETTERIE

ART. COD.

S603

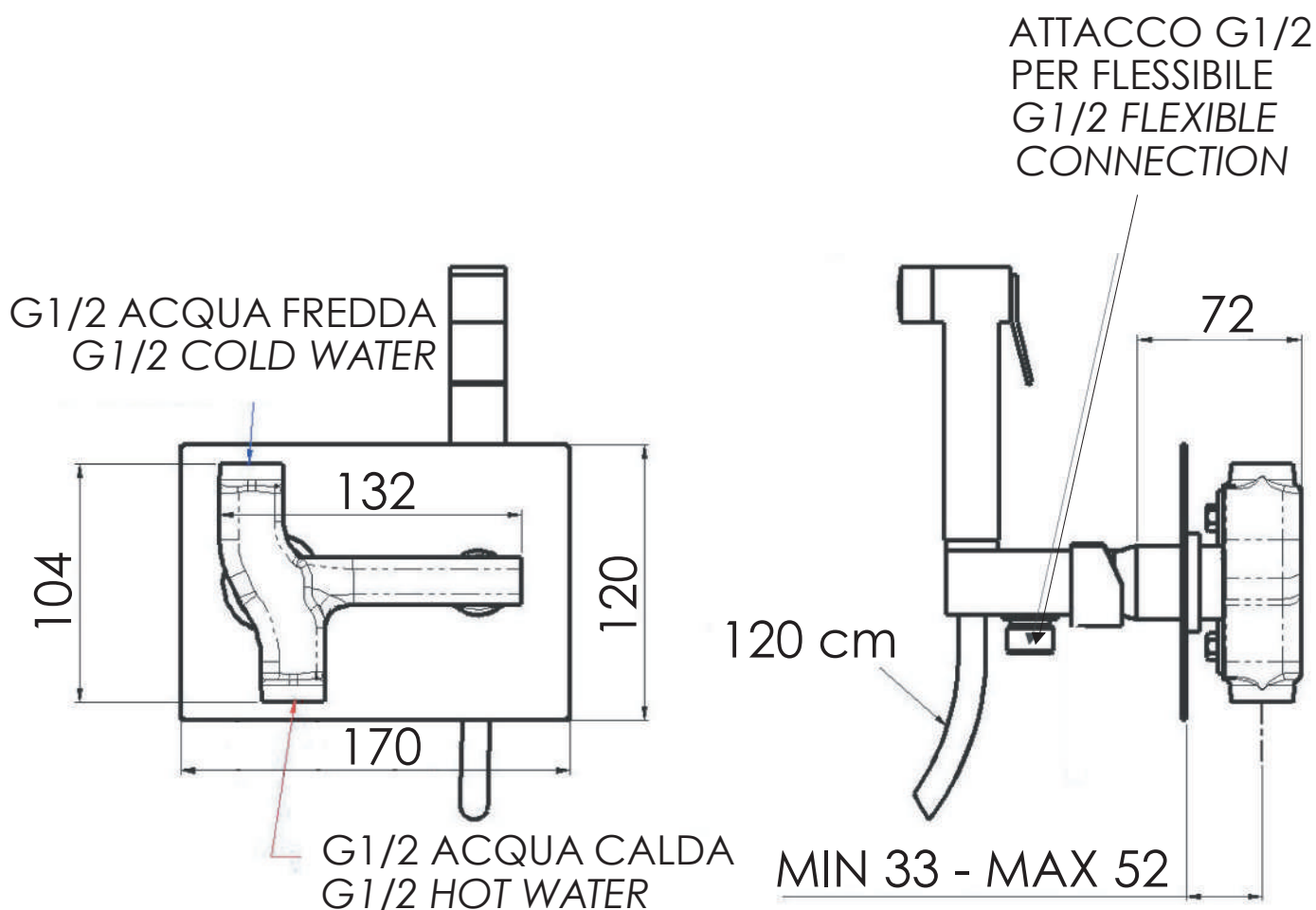

CHIUDERE SEMPRE IL FLUSSO CON LA MANIGLIA DEL MISCELATORE FOPO OGNI UTILIZZO
ALWAYS CLOSE THE FLOW WITH THE MIXER HANDLE AFTER EVERY USE

MATERIALI / MATERIALS

OTTONE CROMATO / CHROME PLATED BRASS

CROMATURA / CHROME PLATING

UNI EN 248

Via Leonardo da Vinci 83 - 20062 Cassano d'Adda (MI) Italy - Tel. +39-0363 364211

info@remer.eu www.remer.eu