

REMER

RUBINETTERIE

SERIE
SERIES

SENSOR

CODICE
CODE

SE16I

IMMAGINE - IMAGE



DESCRIZIONE - DESCRIPTION

Rubinetto elettronico ad azionamento a sensore, mono-acqua dotato di rubinetto sottolavabo con filtro.

Electronic single water tap, with sensor control, equipped with angle valve with filter.

SCHEDA TECNICA - TECHNICAL FEATURES

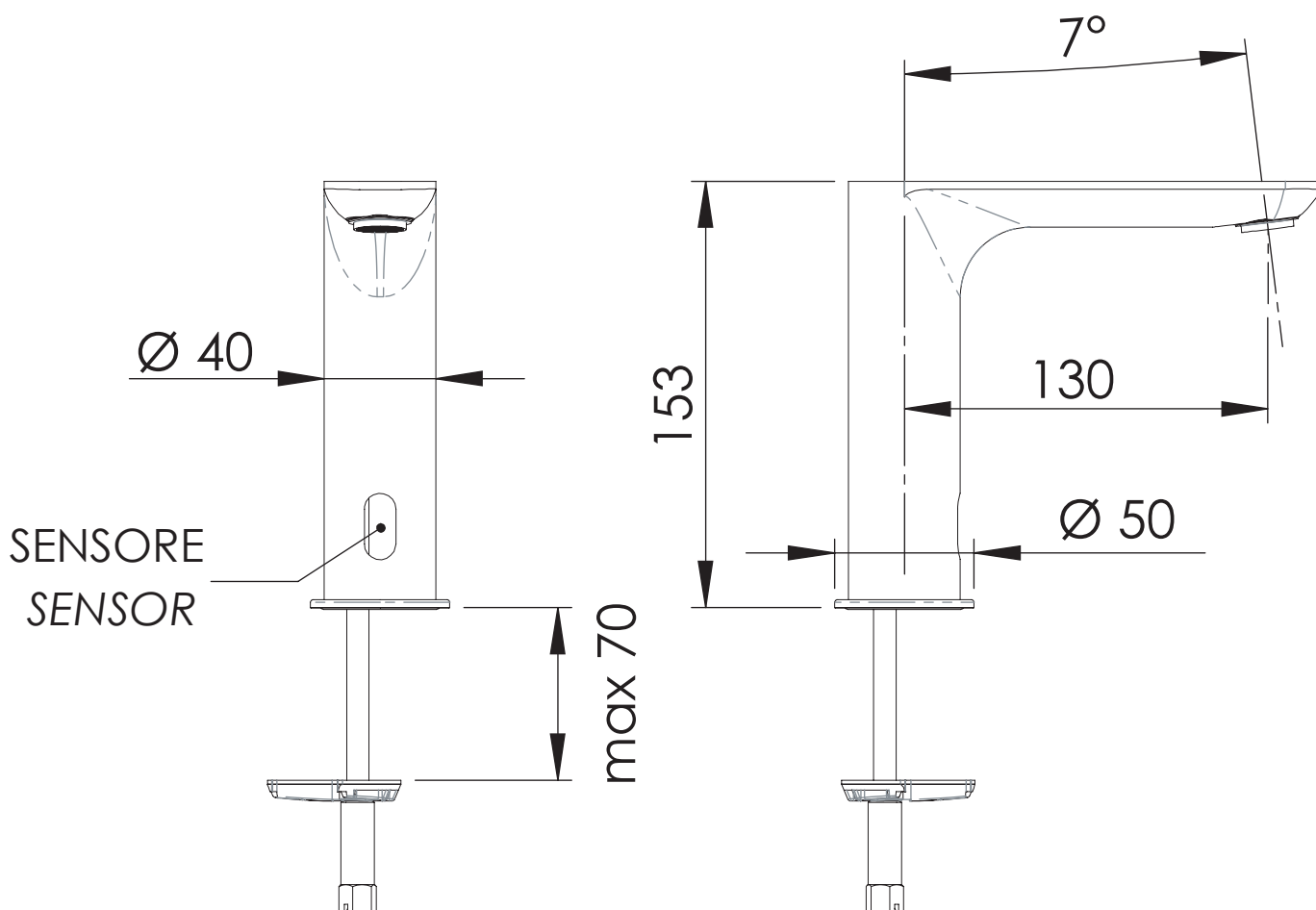

CARATTERISTICHE - FEATURES



Azionamento a Sensore
Sensor Control



Con filtro incluso
With filter included



Con Batterie al Litio Incluse
With Lithium Batteries Included

COMPONENTI - COMPONENTS



Aeratore 83NE
Aerator 83NE

FINITURE - FINISHING



CR
Cromo
Chrome

REMER Rubinetterie S.p.A.

Via Leonardo Da Vinci, 83 - 20062 Cassano d'Adda (MI) - Italy - Tel. +39 0363 364211 - info@remer.eu - www.remer.eu