

REMER

RUBINETTERIE

SERIE
SERIES

COLONNE DOCCIA

SHOWER COLUMNS

ST32LX7AU9SS

CODICE
CODE

IMMAGINE - IMAGE



SCHEMA TECNICA - TECHNICAL FEATURES

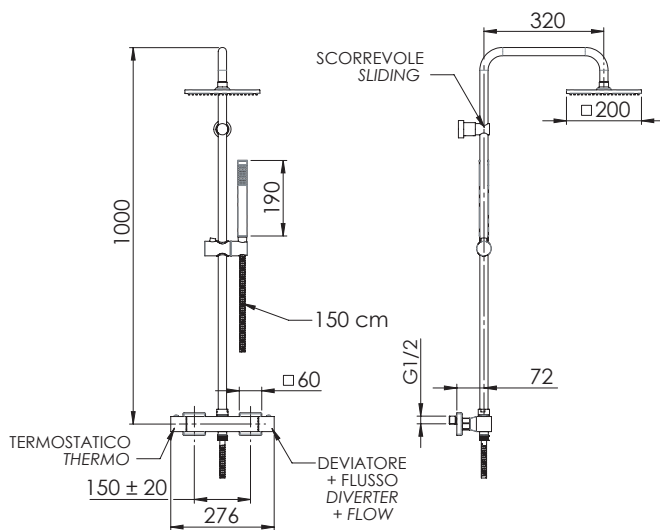

DESCRIZIONE - DESCRIPTION

Set doccia composto da: miscelatore termostatico esterno quadrato con deviatore incorporato, comandi in ottone (ST32L); soffione in ottone cromato 20x20 cm, con getti in silicone soffice anticalcare (359SSX); colonna doccia (329X); doccetta minimale quadrata in ottone (317AU); flessibile 150 cm.

Shower set including: square external thermostatic mixer with integrated diverter, brass handles (ST32L); c.p. brass shower head 20x20 cm, with soft anti-limescale silicone jets (359SSX); shower column (329X); 1-function handshower in c.p. brass (317AU); 150 cm flexible hose.

CARATTERISTICHE - FEATURES



Disponibile in Finitura
Available in Finishing



Getto effetto pioggia ad ampia copertura
Wide coverage rain effect



Flessibile Lungo 150 cm
Flexible Length 150 cm



Getto vigoroso effetto pioggia
Vigorous rain effect jet



Con Getti Anticalcare
With Antilimescale Jets



Termostatico
Thermostatic



3 Vie
3 Ways

COMPONENTI - COMPONENTS



Cartuccia E50P
Cartridge E50P



Cartuccia H50
Cartridge H50

REMER Rubinetterie S.p.A.

Via Leonardo Da Vinci, 83 - 20062 Cassano d'Adda (MI) - Italy - Tel. +39 0363 364211 - info@remer.eu - www.remer.eu