

REMER

RUBINETTERIE



PROFESSIONAL E MINUTERIA
PROFESSIONAL AND MINUTERY

2025

REMER

RUBINETTERIE

**PROFESSIONAL E
MINUTERIA**

***PROFESSIONAL AND
MINUTERY***

RUBINETTERIA - TAPS

REMER
RUBINETTERIE

Giga Four	pag 16	35	pag 32
Kiss	pag 20	1000-2000	pag 38
Remix	pag 28	Complementi doccia - <i>Shower complements</i>	pag 44

FLESSIBILI - FLEXIBLE HOSES

 **FLEXITALY**

Flessibili DN6 acciaio inox <i>Stainless steel DN6 flexibles</i>	pag 50	Flessibili antivibranti inox <i>Stainless steel anti-vibration flexibles</i>	pag 62
Flessibili DN8 acciaio inox <i>Stainless steel DN8 flexibles</i>	pag 52	Tubi di rame <i>Copper tubes</i>	pag 64
Flessibili DN10 acciaio inox <i>Stainless steel DN10 flexibles</i>	pag 55	Adattatori per flessibili <i>Flexible hoses adapter</i>	pag 65
Flessibili DN13 acciaio inox <i>DN13 flexibles stainless steel</i>	pag 58	Raccordi e nipples <i>Connections and nipples</i>	pag 65
Flessibili antivibranti <i>Anti-vibration flexibles</i>	pag 60		

MINUTERIA - MINUTERY

 **RR**
REMER RUBINETTERIE

Rubinetto sottolavabo <i>C.P. Brass angle valve</i>	pag 68	Galleggianti <i>Flushing valves</i>	pag 72
Rosette <i>Wall flanges</i>	pag 70	Rubinetto <i>Taps</i>	pag 73
Canotti, raccordi e tubi <i>Tubes and connectors</i>	pag 71	Accessori per lavatrice <i>Washing machine accessories</i>	pag 76
Passo rapido <i>Flushing valves</i>	pag 72		

VALVOLE - VALVES

 **RR**
REMER RUBINETTERIE

Serie Seven <i>Seven series</i>	pag 80	Serie Reduce Flow <i>Reduce Flow series</i>	pag 86
Serie RR <i>RR series</i>	pag 81	Valvole <i>Valves</i>	pag 87
Serie Full Flow <i>Full Flow series</i>	pag 82	Serie Yellow <i>Yellow series</i>	pag 90
Serie Standard <i>Standard series</i>	pag 84		

RACCORDERIA - FITTINGS



Raccordi in ottone <i>Brass fittings</i>	pag 95	Tubo multistrato RR PEX <i>Multilayer pipe RR PEX</i>	pag 102
Viti doppie <i>Double nipples</i>	pag 99	Analisi del tubo multistrato RR PEX <i>Analysis of the multilayer pipe RR PEX</i>	pag 103
Portagomma <i>Hose holder</i>	pag 99	Accessori per radiatori <i>Radiator accessories</i>	pag 104
Raccordi <i>Fittings</i>	pag 100	Accessori per tubi <i>Accessories for pipes</i>	pag 105
Raccordi in acciaio zincato <i>Galvanized fittings</i>	pag 100		
Serie 495 <i>495 series</i>	pag 102		

ACCESSORI - ACCESSORIES



Rubinetti <i>Faucets</i>	pag 108	Accessori per lavabo <i>Wash basin accessories</i>	pag 118
Cartucce <i>Cartridges</i>	pag 108	Accessori per lavello <i>Sink accessories</i>	pag 118
Deviatori <i>Diverter</i>	pag 110	Accessori per WC ed orinatoio <i>WC and orinals accessories</i>	pag 119
Prolunghe <i>Extensions</i>	pag 110	Accessori per doccia <i>Shower accessories</i>	pag 120
Deviatori automatici <i>Automatic diverters</i>	pag 110	> Canaline sifonate rettangolari <i>Rectangulars floor drains</i>	pag 120
Vitoni <i>Headvalves</i>	pag 111	> Pilette sifonate <i>Siphon drains</i>	pag 121
Linea risparmio idrico <i>Water saving line</i>	pag 112	> Copertura a pavimento in acciaio inox <i>Stainless steel floor drains</i>	pag 121
Riduzioni <i>Reduction</i>	pag 113	> Sifoni antiscaraffaggio <i>Anti cockroach-insect trap</i>	pag 121
Aeratori <i>Aerators</i>	pag 114	Scarichi automatici <i>Pop-up wastes</i>	pag 122
Eccentrici <i>Eccentrics</i>	pag 115	Scarichi automatici click-clack <i>Automatic click-clack pop-up wastes</i>	pag 122
Colonne bordo vasca <i>Vertical connections for bath mixer</i>	pag 115	Sifoni <i>Traps</i>	pag 124
Bocche <i>Spouts</i>	pag 116	> Sifoni salvaspazio <i>Space-saving traps</i>	pag 125
Supporti doccia <i>Hand shower supports</i>	pag 117	Colonne di scarico <i>Bath wastes</i>	pag 126
Scarichi <i>Wastes</i>	pag 117	Accessori per scaldabagno <i>Water heater accessories</i>	pag 127

COMPONENTI PLASTICI - PLASTIC COMPONENTS



Componenti plastici <i>Plastic components</i>	pag 130
--	---------

LA FORZA DI UN GRANDE GRUPPO - THE STRENGTH OF A BIG GROUP

ENGINEERING 1

Dipartimento di produzione con macchinari high-tech, asserviti e robotizzati.
Department of production with high-tech machineries, asserved and robotized.



ENGINEERING 2

Dipartimento di produzione con macchinari high-tech, asserviti e robotizzati. Uffici tecnici e R&D.
Department of production with high-tech machineries, asserved and robotized. Technical and R&D departments.



Produzione flessibili
 Flexible hoses production.



Dipartimento di preassemblaggio e test, dipartimento con impianti di verniciatura a polvere e liquido, dipartimento e impianto di galvanica per la produzione di articoli di pregio.
Pre-assembly and test facilities, powder and liquid vanishing plant and facilities, high-end galvanic electroplating department, plant and facilities.

Sede operativa, controllo finale, spedizioni, uffici commerciali, amministrativi uffici amministrativi
Head offices and factory.



Dipartimento di pulitura, pre-assemblaggio, test di tenuta e controllo qualità.
Polishing department, Test department, pre-assembly department.

REMER

RUBINETTERIE

Remer Rubinetterie nasce a Milano nel 1965 ed è oggi un'imponente realtà produttiva sita a Cassano d'Adda (MI) su un'area di circa 85.000 mq. L'impegno continuo nel crescere, investire, ideare, creare e perfezionarsi è da sempre il motore trainante dell'azienda che si è confermata negli anni come un solido punto di riferimento nella produzione di rubinetteria e minuteria idraulica in Italia e nelle 120 Nazioni estere in cui distribuisce attivamente il proprio prodotto.

Ogni articolo di Remer Rubinetterie esprime il lavoro e la passione di un team di personale qualificato e motivato da una filosofia aziendale di continuo miglioramento. L'offerta a catalogo apre un ampio ventaglio di rubinetteria per bagno e cucina: linee di rubinetteria dai design più innovativi alle forme tradizionali; soluzioni wellness per gli interni doccia; prodotti ad alto contenuto tecnologico per la temporizzazione, la miscelazione termostatica e la cromoterapia; complementi di arredo bagno; cartucce, minuteria, raccorderia, flessibili e materiale idraulico. Ogni articolo prodotto è pensato e realizzato per garantire uno standard qualitativo elevato, costante e duraturo nel tempo.

La grande varietà dell'offerta è un punto chiave nella proposta al Cliente che trova in Remer Rubinetterie un'azienda in grado di fornire, in aggiunta ad una rubinetteria di alta qualità, una notevole scelta di prodotti per l'impiantistica idraulica con un ottimo rapporto qualità/prezzo.

Remer Rubinetterie born in Milan in 1965 and is today an impressive production facility located in Cassano d'Adda (Milan, Italy) on an area of about 85,000 square meters. The continuous commitment to grow, invest, design, create and improve has always been the driving force of the company which has confirmed itself over the years as a solid reference point in faucets and hydraulic small parts manufacturing, in Italy and in 120 foreign countries in which actively distributes its product.

Each Remer Rubinetterie item expresses the work and the passion of a team of qualified personnel motivated by a company philosophy of continuous improvement. The catalogue of Remer Rubinetterie offers up a wide range of bathroom and kitchen faucets: complete faucet collections from the most innovative designs to traditional shapes; wellness solutions for shower interiors; high-tech products for timed flow taps, thermostatic mixing and chromotherapy; bathroom accessories; cartridges, small parts, fittings, flexible hoses and hydraulic material. Each product is designed and manufactured to guarantee a high, constant and long-lasting quality standard.

The huge variety of the offer is a key point in our proposal to the Customer who finds in Remer Rubinetterie a Company able to supply, in addition to high quality faucets, a considerable choice of products for hydraulic systems with an excellent quality / price ratio.



LE NOSTRE CERTIFICAZIONI:

Remer Rubinetterie S.p.A. è un'azienda certificata UNI EN ISO 9001:2008 sistema di gestione qualità aziendale e UNI EN ISO 14001: 2004 per l'impatto ambientale.



OUR CERTIFICATIONS:

Remer Rubinetterie S.p.A. is a UNI EN ISO 9001:2008 certified factory for the quality system and UNI EN ISO 14001: 2004 for environmental impact.

Remer Rubinetterie S.p.A.
Via Leonardo da Vinci, 83
20062 Cassano d'Adda (MI) Italy
Tel. +39 0363 364 211
E-Mail: info@remer.eu



www.remer.eu



@remerrubinetterieofficial



#remerrubinetterie



Remer Rubinetterie



Remer Rubinetterie

I NOSTRI STABILIMENTI PRODUTTIVI



Il Gruppo Remer è da sempre alla ricerca di sviluppo e tecnologia e soprattutto negli ultimi anni questo processo ha avuto un incremento notevole che ha portato alla nascita di nuovi stabilimenti di produzione con lo scopo di accentrare tutte le fasi produttive. All'interno del nostro gruppo si trovano macchinari di ultima generazione che permettono di realizzare il prodotto finito.

Parliamo di cicli completi che vanno dalla progettazione alla realizzazione dei manufatti, tutto all'interno dei nostri stabilimenti.

Possiamo elencare i nostri macchinari più sofisticati quali (ma non solo):

- centri di lavoro con robots,
- centri di lavoro con visori ottici e robots,
- transfer a 3 assi,
- transfer a doppia barra
- torni con caricatori,
- macchinari per il taglio barra piena o forata e in tubo,
- macchinari per il taglio tubi e lavorazione canotti e aste
- impianti per il taglio della lastra di ottone o altri metalli,
- grande dipartimento di stampaggio plastica con numerose macchine multimarca.

In più:

- grande area dedicata alla lucidatura e pulitura con numerosi impianti automatici robotizzati e sistemi manuali,
- grande impianto di cromatura ad alta qualità,
- dipartimento per la creazione di stampi,
- grande e sofisticata area test prodotto e controllo qualità,
- spettrometro per analisi materia prima,
- linee automatiche di confezionamento,
- impianti per insacchettamento in automatico,
- macchine taglio spugna,
- imballaggio in termoformato in automatico,
- linee automatiche di confezionamento.
- controllo e gestione della produzione e degli ordini totalmente automatizzata con stazioni pc e radio frequenza in tutti gli stabilimenti.

Remer Group has always been searching for innovation and technology and during the last few years this process had a remarkable acceleration that drove to the centralisation of all our production plants between Milan and Bergamo area, to group all our production phases and implement our logistics. Inside these plants there are the most sophisticated Italian last generation machineries that permit to manufacture until the finished product.

Therefore we are talking about a complete cycle that goes from the design to the finished product.

We can list our sophisticated machineries like (but not only):

- work stations with robots,
- work stations with optical viewers and robots,
- 3-ways transfers- several robotised and automatic polishing machines,
- double bar transfers,
- lathes with loaders,
- full bar and tube bar cutters,
- pipes cutters and machineries to process tubes and rods,
- brass plate or other metals cutters,
- forging and injection machines department.

Furthermore:

- robotised and automatic polishing machines,
- high quality chrome plating system,
- tooling and moulds creation laboratory,
- sophisticated testing quality control machinery departments,
- spectrometer for analysis of raw material,
- automatic packaging,
- automatic bagging systems,
- sponge-cutters,
- thermo format machines,
- automatic packaging systems,
- radio frequency automatic orders control in each department.



OUR PRODUCTION PLANTS

Un ciclo produttivo automatizzato e interno alle aziende del gruppo Remer che permette di selezionare con cura le materie prime utilizzate e di seguire con attenzione ogni fase di lavorazione: dalla minuteria alla rubinetteria, dalla progettazione al prodotto finito.

An automated production cycle within the Remer Group Companies allows to carefully select each material and to carefully follow each stage of our manufacturing: from small parts to faucets, from design to finished product.



Grandi spazi completamente attrezzati con macchinari italiani di ultima generazione.

Large spaces fully equipped with the latest Italian machinery









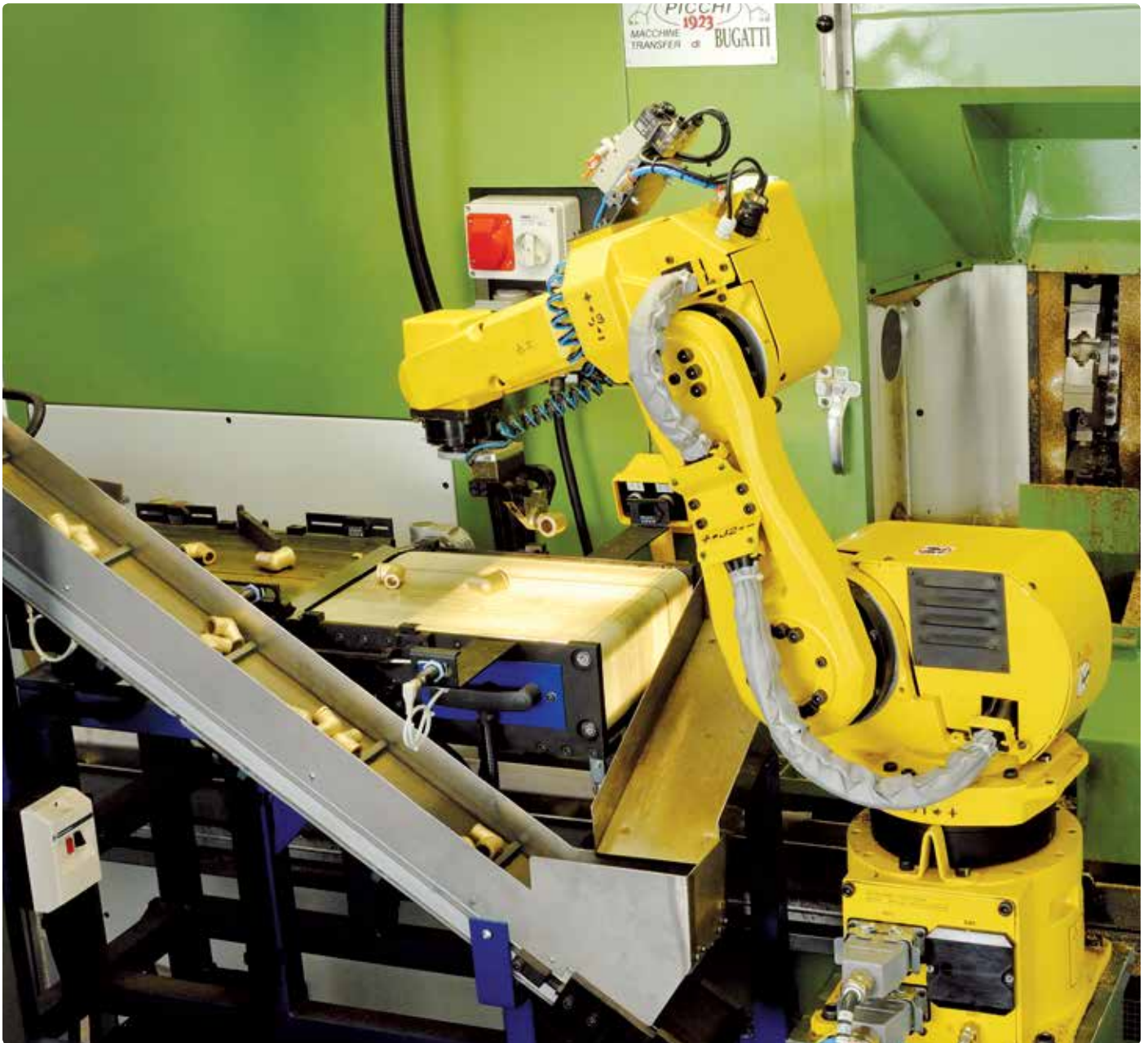



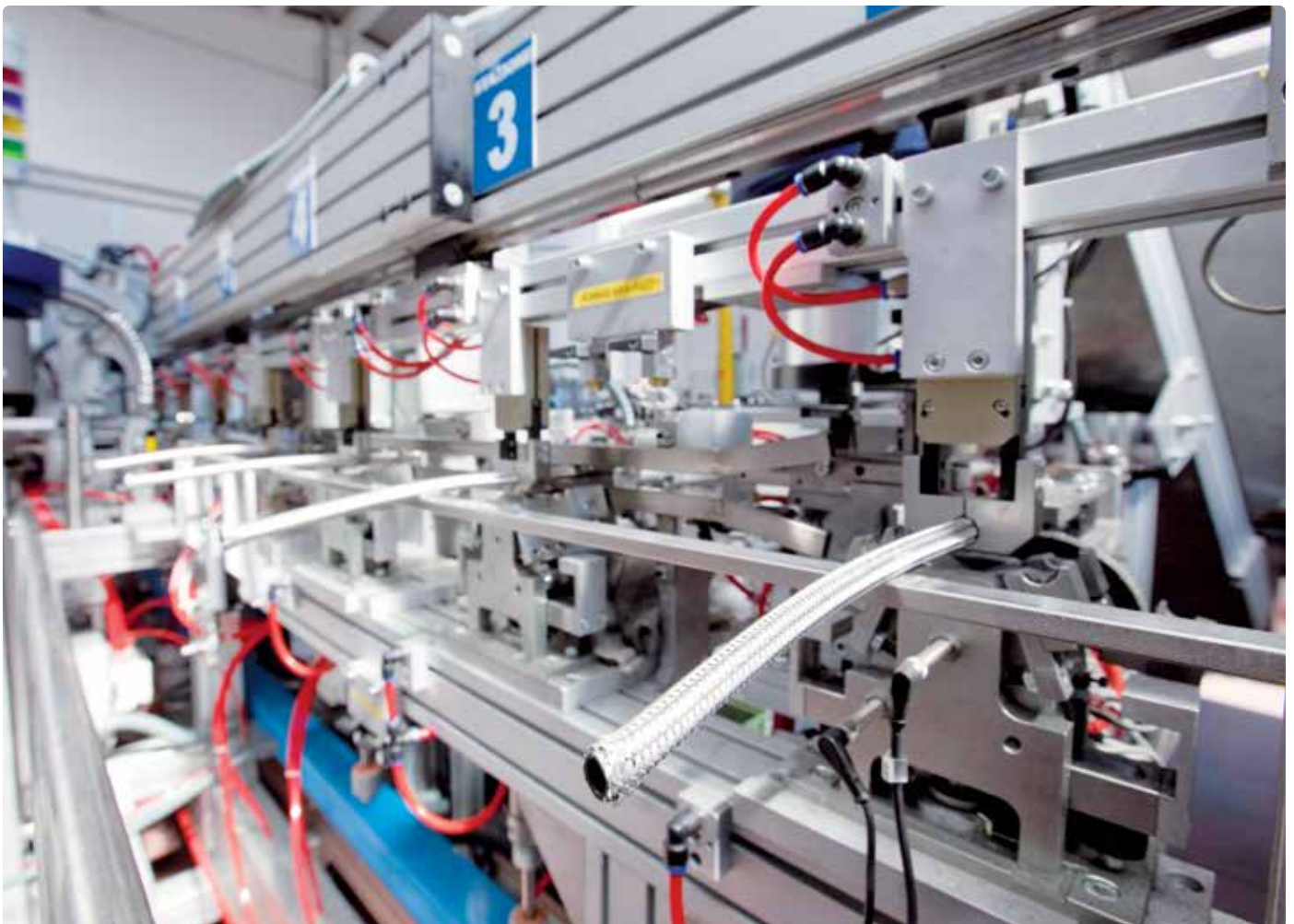

REMER
RUBINETTERIE

RUBINETTERIA TAPS



RUBINETTERIA
TAPS

FLESSIBILI
FLEXIBLE HOSES

MINUTERIA
MINUTERY

VALVOLE
VALVES

RACCORDERIA
FITTINGS

ACCESSORI
ACCESSORIES

COMPONENTI PLASTICI
PLASTIC COMPONENTS



GIGA FOUR

La serie è dotata di cartuccia a dischi ceramici Ø 40 mm.
The series is equipped with a Ø 40 mm ceramic disc cartridge.



OPZIONI MANIGLIA

La collezione è disponibile con diverse varianti di maniglia. Selezionare la preferenza al momento dell'ordine.

LEVER OPTIONS

The collection is available with different lever options. Select your preference before ordering.



LAVABI E BIDET - WASHBASIN AND BIDET MIXERS



G104

Miscelatore monocomando lavabo, con scarico.
Single-lever basin mixer, with pop-up waste.

CR



G204

Miscelatore monocomando per bidet, con aeratore direzionabile, con scarico.
Single-lever bidet mixer with adjustable aerator, with pop-up waste.

CR



G114

Miscelatore monocomando lavabo, senza scarico.
Single-lever basin mixer, without waste.

CR



G214

Miscelatore monocomando per bidet, con aeratore direzionabile, senza scarico.
Single-lever bidet mixer with adjustable aerator, without waste.

CR



VASCA - BATH MIXERS



G024
 Miscelatore monocomando per vasca, esterno. Con doccetta in ABS anticalcare ad 1 funzione e supporto snodato flessibile 150 cm.
 Single-lever external bath mixer, with 1 function antilimestone ABS handshower and swivel shower holder, flexible hose 150 cm.

CR

G054
 Miscelatore monocomando per vasca, esterno. Senza kit doccia.
 Single-lever external bath mixer, without shower kit.

CR



G034
 Miscelatore monoforo lavabo/vasca con deviatore integrato, con doccetta in ABS anticalcare ad 1 funzione e supporto snodato, flessibile 150 cm.
 Single-lever one-hole basin/bath mixer with diverter, with 1 function antilimestone ABS handshower and swivel shower holder, flexible hose 150 cm.

CR

G044
 Miscelatore monoforo lavabo/vasca con deviatore integrato, senza kit doccia.
 Single-lever one-hole basin/bath mixer with diverter, without shower kit.

CR



G074
 Miscelatore monocomando bordo vasca con deviatore integrato nella bocca, e doccetta in ABS estraibile con idromassaggio e anticalcare a 4 funzioni.
 Single lever deck bath/shower mixer with diverter integrated on the spout, antilimestone pull-out ABS handshower 4 functions.

CR



G074UF
 Miscelatore monocomando bordo vasca con deviatore integrato nel miscelatore, bocca effetto cascata e doccetta estraibile in ABS a 4 funzioni anticalcare.
 Single lever deck bath/shower mixer with diverter integrated on the mixer, spout with waterfall jet, antilimestone pull-out ABS handshower 4 functions.

CR



DOCCE - SHOWER MIXERS



G384
 Miscelatore monocomando esterno doccia con leva frontale, con doccetta in ABS anticalcare ad 1 funzione e supporto snodato flessibile 150 cm.
 Wall mounted single-lever shower mixer with frontal lever, with 1 function antilimestone ABS handshower and swivel shower holder, flexible hose 150 cm.

CR

G334
 Miscelatore monocomando esterno doccia con leva frontale, senza kit doccia.
 Wall mounted single-lever shower mixer with frontal lever, without shower kit.

CR

INCASSI DOCCIA - BUILT-IN MIXERS



G304
 Miscelatore monocomando incasso doccia.
 Built-in single-lever shower mixer.

CR



G094
 Miscelatore monocomando incasso vasca/doccia con deviatore.
 Built-in single-lever bath/shower mixer with diverter.

CR

RUBINETTERIA
TAPS

FLESSIBILI
FLEXIBLE HOSES

MINUTERIA
MINUTERY

VALVOLE
VALVES

RACCORDERIA
FITTINGS

ACCESSORI
ACCESSORIES

COMPONENTI PLASTICI
PLASTIC COMPONENTS

CUCINA - KITCHEN MIXERS



G404
 Miscelatore monocomando per lavello, con bocca girevole.
 Single-lever one-hole sink mixer, with swivel spout.

CR

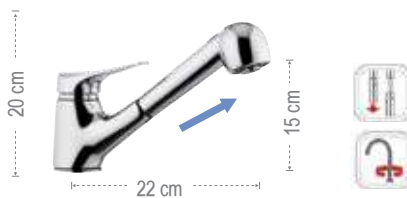

G474
 Miscelatore monocomando per lavello, con doccia estraibile a getto variabile.
 Single-lever one-hole sink mixer, with pull-out spray jet shower, 2 functions.

CR



G424R
 Miscelatore monocomando monoforo 90° per lavello, con bocca alta girevole ed orientabile, tipo lusso, modello sottofinestra.
 Single-lever one-hole sink mixer, with high spout swivel and orientable, luxury type, under window type.

CR



G424
 Miscelatore monocomando per lavello, con bocca alta girevole, tipo lusso.
 Single-lever one-hole sink mixer, with high swivel spout, luxury type.

CR



G424C
 Miscelatore monocomando per lavello, con bocca girevole, modello corto, tipo lusso.
 Single-lever one-hole sink mixer, with swivel spout, luxury type, shorter model.

CR



G424U
 Miscelatore monocomando per lavello, con bocca alta a "U" girevole.
 Single-lever one-hole sink mixer, with high "U" swivel spout.

CR



G434
 Miscelatore monocomando per lavello a muro, con leva frontale e bocca alta girevole.
 Single-lever wall mounted sink mixer, with frontal lever and high swivel spout.

CR



G434C
 Miscelatore monocomando per lavello a muro, con leva frontale e bocca girevole modello corto.
 Single-lever wall mounted sink mixer, with frontal lever and swivel spout, shorter model.

CR



RUBINETTERIA
TAPS

FLESSIBILI
FLEXIBLE HOSES

MINUTERIA
MINUTERY

VALVOLE
VALVES

RACCORDERIA
FITTINGS

ACCESSORI
ACCESSORIES

COMPONENTI PLASTICI
PLASTIC COMPONENTS

KISS

La serie è dotata di cartuccia a dischi ceramici Ø 40 mm.
The series is equipped with a Ø 40 mm ceramic disc cartridge.



OPZIONI MANIGLIA

La collezione è disponibile con diverse varianti di maniglia.
Selezionare la preferenza al momento dell'ordine.

LEVER OPTIONS

The collection is available with different lever options.
Select your preference before ordering.



LAVABI - WASHBASIN MIXERS



K10
Miscelatore monocomando lavabo, con scarico.
Single-lever basin mixer, with pop-up waste.

CR



K10P
Miscelatore monocomando lavabo, con scarico in plastica.
Single-lever basin mixer, with plastic pop-up waste.

CR



K11
Miscelatore monocomando lavabo, senza scarico.
Single-lever basin mixer, without waste.

CR



K10L
Miscelatore monocomando per lavabo, con bocca lunga. Con scarico.
Single-lever basin mixer with long spout. With pop-up waste.
CR



K10LP
Miscelatore monocomando per lavabo, con bocca lunga. Con scarico in plastica.
Single-lever basin mixer with long spout. With plastic pop-up waste.
CR



K11L
Miscelatore monocomando per lavabo, con bocca lunga. Senza scarico.
Single-lever basin mixer with long spout. Without waste.
CR



K11G
Miscelatore monocomando per lavabo o lavello, con bocca girevole, senza scarico.
Single-lever one-hole basin or sink mixer, with swivel spout, without waste.
CR



K10E
Miscelatore monocomando lavabo con bocca estraibile con scarico.
Single-lever basin mixer with pull-out spout and pop-up waste.
CR

BIDET - BIDET MIXERS



K20
Miscelatore monocomando per bidet, con aeratore direzionabile, con scarico.
Single-lever bidet mixer with adjustable aerator, with pop-up waste.
CR

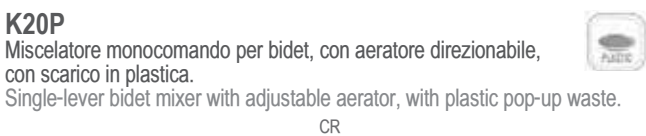

K20P
Miscelatore monocomando per bidet, con aeratore direzionabile, con scarico in plastica.
Single-lever bidet mixer with adjustable aerator, with plastic pop-up waste.
CR

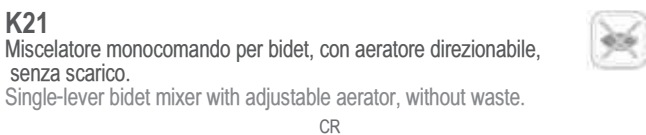

K21
Miscelatore monocomando per bidet, con aeratore direzionabile, senza scarico.
Single-lever bidet mixer with adjustable aerator, without waste.
CR



K23
Miscelatore monocomando per bidet, con doccia, senza scarico.
Single-lever bidet mixer with spray, without waste.
CR



K24
Miscelatore monocomando per bidet, con deviatore e doccia, senza scarico.
Single-lever bidet mixer with diverter and spray, without waste.
CR

VASCA - BATH MIXERS



K02

Miscelatore monocomando per vasca, esterno. Con doccetta in ABS anticalcare ad 1 funzione e supporto snodato flessibile 150 cm.
Single-lever external bath mixer, with 1 function antilimestone ABS handshower and swivel shower holder, flexible hose 150 cm.

CR



K08UK

Miscelatore monocomando per vasca, su colonnette. Con doccetta in ABS anticalcare ad 1 funzione e supporto snodato flessibile 150 cm.
Single-lever external bath mixer on columns, with 1 function antilimestone ABS handshower and swivel shower holder, flexible hose 150 cm.

CR



K49

Miscelatore lavabo/vasca con canna fusa lunga e deviatore, con doccetta in ABS anticalcare ad 1 funzione e supporto snodato, flessibile 150 cm.
Wall basin/bath single lever mixer with long casted spout with diverter, with 1 function antilimestone ABS handshower and swivel shower holder, flexible hose 150 cm.

CR

K05

Miscelatore monocomando per vasca, esterno. Senza kit doccia.
Single-lever external bath mixer, without shower kit.

CR

K01

Miscelatore monocomando per vasca, su colonnette. Senza kit doccia.
Single-lever external bath mixer on columns, without shower kit.

CR

K46

Miscelatore lavabo/vasca con canna fusa lunga e deviatore, senza kit doccia.
Wall basin/bath single lever mixer with long casted spout with diverter, without shower kit.

CR



CR



CR



CR

K03

Miscelatore monoforo lavabo/vasca con deviatore integrato, con doccetta in ABS anticalcare ad 1 funzione e supporto snodato, flessibile 150 cm.
Single-lever one-hole basin/bath mixer with diverter, with 1 function antilimestone ABS handshower and swivel shower holder, flexible hose 150 cm.



K07

Miscelatore monocomando bordo vasca con deviatore integrato nel miscelatore, bocca effetto cascata e doccetta estraibile in ABS a 4 funzioni anticalcare.
Single lever deck bath/shower mixer with diverter integrated on the mixer, spout with waterfall jet, antilimestone pull-out ABS handshower 4 functions.



K07UF

Miscelatore monocomando bordo vasca con deviatore integrato nella bocca, e doccetta in ABS estraibile con idromassaggio e anticalcare a 4 funzioni.
Single lever deck bath/shower mixer with diverter integrated on the spout, antilimestone pull-out ABS handshower 4 functions.



K04

Miscelatore monoforo lavabo/vasca con deviatore integrato, senza kit doccia.
Single-lever one-hole basin/bath mixer with diverter, without shower kit.

CR

DOCCE - SHOWER MIXERS



311311DA

Saliscendi con doccetta anticalcare, con getti in silicone.
Sliding rail set with antilime handshower.

CR



K38

Miscelatore monocomando esterno doccia con leva frontale, con doccetta in ABS anticalcare ad 1 funzione e supporto snodato flessibile 150 cm.
Wall mounted single-lever shower mixer with frontal lever, with 1 function antilime ABS handshower and swivel shower holder, flexible hose 150 cm.

CR

K33

Miscelatore monocomando esterno doccia con leva frontale, senza kit doccia.
Wall mounted single-lever shower mixer with frontal lever, without shower kit.

CR



K39

Miscelatore monocomando esterno doccia, con doccetta in ABS anticalcare ad 1 funzione e supporto snodato flessibile 150 cm.
Wall mounted single-lever shower mixer, with 1 function antilime ABS handshower and swivel shower holder, flexible hose 150 cm.

CR

K31

Miscelatore monocomando esterno doccia, senza kit doccia.
Wall mounted single-lever shower mixer, without shower kit.

CR

INCASSI DOCCIA - BUILT-IN MIXERS



K30

Miscelatore monocomando incasso doccia.
Built-in single-lever shower mixer.

CR



K09

Miscelatore monocomando incasso vasca/doccia con deviatore.
Built-in single-lever bath/shower mixer with diverter.

CR

CUCINA - KITCHEN MIXERS



K40

Miscelatore monocomando per lavello, con bocca girevole.
Single-lever one-hole sink mixer, with swivel spout.

CR



K47

Miscelatore monocomando per lavello, con doccia estraibile a getto variabile.
Single-lever one-hole sink mixer, with pull-out spray jet shower, 2 functions.

CR



K42R

Miscelatore monocomando monoforo 90° per lavello, con bocca alta girevole ed abbattibile, tipo lusso, modello sottofinestra.
Single-lever one-hole sink mixer, with high spout swivel and foldable, luxury type, under window type.

CR

RUBINETTERIA
TAPS

FLESSIBILI
FLEXIBLE HOSES

MINUTERIA
MINUTERY

VALVOLE
VALVES

RACCORDERIA
FITTINGS

ACCESSORI
ACCESSORIES

COMPONENTI PLASTICI
PLASTIC COMPONENTS



K42
Miscelatore monocomando per lavello, con bocca alta girevole, tipo lusso.
Single-lever one-hole sink mixer, with high swivel spout, luxury type.

CR



K42C
Miscelatore monocomando per lavello, con bocca girevole, modello corto, tipo lusso.
Single-lever one-hole sink mixer, with swivel spout, luxury type, shorter model.

CR



K42U
Miscelatore monocomando per lavello, con bocca alta a "U" girevole.
Single-lever one-hole sink mixer, with high "U" swivel spout.

CR



K43
Miscelatore monocomando per lavello a muro, con leva frontale e bocca alta girevole.
Single-lever wall mounted sink mixer, with frontal lever and high swivel spout.

CR



K43C
Miscelatore monocomando per lavello a muro, con leva frontale e bocca girevole modello corto.
Single-lever wall mounted sink mixer, with frontal lever and swivel spout, shorter model.

CR



K41
Miscelatore monocomando per lavello a muro, con bocca girevole.
Single-lever wall mounted sink mixer, with swivel spout.

CR

LINEA PARRUCCHIERE - HAIRDRESSER LINE MIXER



K41S
Miscelatore monocomando per lavello a muro, con bocca a "S" girevole.
Single-lever wall mounted sink mixer, with "S" swivel spout.

CR



K66
Mixer per acconciatore completo con doccia estraibile.
Barber mixer complete with pull-out shower.

CR

LINEA CLINICA BAGNO - BASIN CLINIC LINE MIXERS



K14
Miscelatore lavabo con scarico e leva lunga.
Wash basin mixer with pop-up waste and long lever.

CR



K14L
Miscelatore lavabo con bocca lunga, scarico e leva lunga.
Wash basin mixer with long spout, pop-up waste and long lever.

CR



K11GLL
Miscelatore monocomando per lavabo o lavello, con bocca girevole e leva lunga, senza scarico.
Single-lever one-hole basin or sink mixer, with swivel spout and long lever, without waste.

CR



LINEA CLINICA DOCCIA
SHOWER CLINIC LINE MIXERS



K39LL
Miscelatore monocomando esterno doccia con leva lunga, con doccetta in ABS anticalcare ad 1 funzione e supporto snodato flessibile 150 cm.
Wall mounted single-lever shower mixer with long lever, with 1 function antilimestone ABS handshower and swivel shower holder, flexible hose 150 cm.

CR



K31LL
Miscelatore monocomando esterno doccia con leva lunga, senza kit doccia.
Wall mounted single-lever shower mixer with long lever, without shower kit.

CR

RUBINETTERIA
TAPS

FLESSIBILI
FLEXIBLE HOSES

MINUTERIA
MINUTERY

VALVOLE
VALVES

RACCORDERIA
FITTINGS

ACCESSORI
ACCESSORIES

COMPONENTI PLASTICI
PLASTIC COMPONENTS

LINEA CLINICA CUCINA - KITCHEN CLINIC LINE MIXERS



K44
Miscelatore lavello con bocca girevole e leva lunga.
Sink mixer with swivel spout and long lever.

CR



K42LL
Miscelatore monocomando per lavello, con bocca alta girevole e leva lunga.
Single-lever one-hole sink mixer, with high swivel spout and long lever.

CR

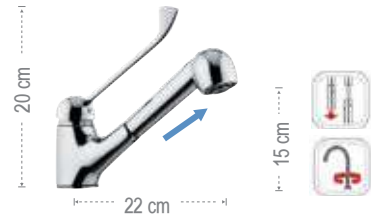

K47LL
Miscelatore monocomando per lavello con leva lunga e doccia estraibile a getto variabile.
Single-lever one-hole sink mixer with long lever and with pull-out spray jet shower with 2 functions.

CR



K45
Miscelatore monocomando per lavello a muro con leva lunga e bocca girevole.
Wall mounted single lever sink mixer with swivel spout and long lever.

CR



K45S
Miscelatore monocomando per lavello a muro con leva lunga e bocca a "S" girevole.
Wall mounted single lever sink mixer with swivel "S" spout and long lever.

CR

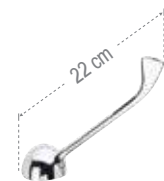

MA14
Leva lunga per miscelatori con cartuccia Ø 40.
Spare long lever for single lever mixers with cartridge Ø 40.

CR

LINEA ACQUA POTABILE - DRINKING WATER LINE MIXERS



K40AP
Miscelatore monocomando per lavello, con bocca girevole, con selettore per acqua potabile (tre vie di ingresso).
Single-lever one-hole sink mixer, with swivel spout, with selector for drinking water (three ways inlet).

CR



K40DW
Miscelatore lavello a tre vie di ingresso con bocca girevole, con selezione acqua potabile tramite la leva, con 2 aeratori in uscita.
Three ways inlet single lever sink mixer, with swivel spout, with selection for drinking water directly from the lever, with 2 exit aerators.

CR

LINEA BASSA PRESSIONE - LOW PRESSURE LINE MIXERS



K40BP
Miscelatore monocomando per lavello, con bocca girevole, per bassa pressione.
Single-lever one-hole sink mixer, with swivel spout, for low pressure.

CR



K40BPC
Miscelatore monocomando per lavabo o lavello, con bocca girevole corta, per bassa pressione.
Single-lever one-hole basin or sink mixer, with short swivel spout, for low pressure.

CR



K41BP
Miscelatore monocomando per lavello a muro, con bocca girevole, per bassa pressione.
Single-lever wall mounted sink mixer, with swivel spout, for low pressure.

CR

LINEA MONO ACQUA - SINGLE WATER LINE MIXERS



K11M
Miscelatore monocomando e monoacqua per lavabo senza scarico.
Single-lever single-water line basin mixer without waste.

CR



K11GM
Miscelatore monocomando e monoacqua per lavabo o lavello, con bocca girevole, senza scarico.
Single-lever single-water line basin or sink mixer, with swivel spout, without waste.

CR



K42M
Miscelatore monocomando mono acqua per lavello, con bocca alta girevole.
Single-lever single-water one-hole sink mixer, with high swivel spout.

CR



K42UM
Miscelatore monocomando monoacqua per lavello, con bocca alta a "U" girevole.
Single-lever single water one-hole sink mixer, with high "U" swivel spout.

CR



K40M
Miscelatore monocomando mono acqua per lavello, con bocca girevole.
Single-lever single-water one-hole sink mixer, with swivel spout.

CR

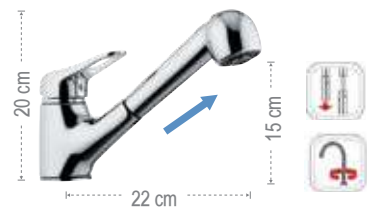

K47M
Miscelatore monocomando monoacqua per lavello, con doccia estraibile a getto variabile.
Single-lever single water one-hole sink mixer, with pull-out spray jet shower two functions.

CR

RUBINETTERIA
TAPS

FLESSIBILI
FLEXIBLE HOSES

MINUTERIA
MINUTERY

VALVOLE
VALVES

RACCORDERIA
FITTINGS

ACCESSORI
ACCESSORIES

COMPONENTI PLASTICI
PLASTIC COMPONENTS

REMIX

La serie è dotata di cartuccia a dischi ceramici Ø 35 mm.
The series is equipped with a Ø 35 mm ceramic disc cartridge.



OPZIONI MANIGLIA

La collezione è disponibile con diverse varianti di maniglia. Selezionare la preferenza al momento dell'ordine.

LEVER OPTIONS

The collection is available with different lever options. Select your preference before ordering.

R10



R102



R103



R104



R106



R107



LAVABI E BIDET - WASHBASIN AND BIDET MIXERS



R10

Miscelatore monocomando lavabo, con scarico.
Single-lever basin mixer, with pop-up waste.

CR



R10P

Miscelatore monocomando lavabo, con scarico in plastica.
Single-lever basin mixer, with plastic pop-up waste.

CR



R11

Miscelatore monocomando lavabo, senza scarico.
Single-lever basin mixer, without waste.

CR



R20
Miscelatore monocomando per bidet con aeratore direzionabile, con scarico.
Single-lever bidet mixer with adjustable aerator, with pop-up waste.

CR



R20P
Miscelatore monocomando per bidet con aeratore direzionabile, con scarico in plastica.
Single-lever bidet mixer with adjustable aerator, with plastic pop-up waste.

CR



R21
Miscelatore monocomando per bidet con aeratore direzionabile, senza scarico.
Single-lever bidet mixer with adjustable aerator, without waste.

CR



R11G
Miscelatore monocomando per lavabo o lavello, con bocca girevole, senza scarico.
Single-lever one-hole basin or sink mixer, with swivel spout, without waste.

CR

VASCA - BATH MIXERS



R02
Miscelatore monocomando per vasca esterno, con doccetta in ABS anticalcare ad 1 funzione e supporto snodato flessibile 150 cm.
Single-lever external bath mixer, with 1 function antilimestone ABS handshower and swivel shower holder, flexible hose 150 cm.

CR



R49
Miscelatore lavabo/vasca con canna fusa lunga e deviatore, con doccetta in ABS anticalcare ad 1 funzione e supporto snodato, flessibile 150 cm.
Wall basin/bath single lever mixer with long casted spout with diverter, with 1 function antilimestone ABS handshower and swivel shower holder, flexible hose 150 cm.

CR



R07
Miscelatore monocomando bordo vasca serie Remix con deviatore integrato nella bocca, bocca fusa e doccetta estraibile ad 1 funzione.
Single lever deck bath/shower mixer with diverter integrated on the spout, casted spout, antilimestone pull-out handshower 1 function.

CR

R05
Miscelatore monocomando per vasca esterno, senza kit doccia.
Single-lever external bath mixer, without shower kit.

CR

R46
Miscelatore lavabo/vasca con canna fusa lunga e deviatore, senza kit doccia.
Wall basin/bath single lever mixer with long casted spout with diverter, without shower kit.

CR

RUBINETTERIA
TAPS

FLESSIBILI
FLEXIBLE HOSES

MINUTERIA
MINUTERY

VALVOLE
VALVES

RACCORDERIA
FITTINGS

ACCESSORI
ACCESSORIES

COMPONENTI PLASTICI
PLASTIC COMPONENTS

DOCCE - SHOWER MIXERS



R39

Miscelatore monocomando esterno doccia, con doccetta in ABS anticalcare ad 1 funzione e supporto snodato flessibile 150 cm.
Wall mounted single-lever shower mixer, with 1 function antilimestone ABS handshower and swivel shower holder, flexible hose 150 cm.

CR



R38

Miscelatore monocomando esterno doccia con leva frontale, con doccetta in ABS anticalcare ad 1 funzione e supporto snodato flessibile 150 cm.
Wall mounted single-lever shower mixer with frontal lever, with 1 function antilimestone ABS handshower and swivel shower holder, flexible hose 150 cm.

CR

R31

Miscelatore monocomando esterno doccia, senza kit doccia.
Wall mounted single-lever shower mixer, without shower kit.

CR

R33

Miscelatore monocomando esterno doccia con leva frontale, senza kit doccia.
Wall mounted single-lever shower mixer with frontal lever, without shower kit.

CR



R37

Colonna doccia con deviatore, completa di doccetta anticalcare 4 getti, flessibile 150 cm e soffione 4 getti anticalcare.
Shower column with diverter, complete with handshower antilimestone 4 jets, flexible hose 150 cm and shower head, 4 jets antilimestone.

CR



311311DA

Saliscendi con doccetta anticalcare, con getti in silicone.
Sliding rail set with antilimestone handshower.

CR



INCASSI DOCCIA - BUILT-IN MIXERS



R30

Miscelatore monocomando incasso doccia completo.
Complete built-in single-lever shower mixer.

CR

N30B

Parte interna miscelatore monocomando incasso doccia.
Single-lever shower mixer (built-in components).

CR

R30E

Parte esterna miscelatore monocomando incasso doccia.
Single-lever shower mixer (external components).

CR



R09

Miscelatore monocomando incasso vasca/doccia con deviatore.
Built-in single-lever bath/shower mixer with diverter.

CR

N09B

Parte interna miscelatore monocomando incasso vasca/doccia con deviatore.
Single-lever bath/shower mixer with diverter (built-in components).

CR

R09E

Parte esterna miscelatore monocomando incasso vasca/doccia con deviatore.
Single-lever bath/shower mixer with diverter (external components).

CR

CUCINA - KITCHEN MIXERS



R40
Miscelatore monocomando per lavello, con bocca girevole.
Single-lever one-hole sink mixer, with swivel spout.

CR



R42B
Miscelatore monocomando per lavello, con bocca alta girevole.
Single-lever one-hole sink mixer, with high swivel spout.

CR



R42R
Miscelatore monocomando monoforo 90° per lavello, con bocca alta girevole ed abbattibile, tipo lusso, modello sottofinestra.
Single-lever one-hole sink mixer, with high swivel and foldable spout, luxury type, under window type.

CR



R42
Miscelatore monocomando per lavello, con bocca alta girevole.
Single-lever one-hole sink mixer, with high swivel spout.

CR



R42C
Miscelatore monocomando per lavello, con bocca a "C" girevole, tipo lusso modello corto.
Single-lever one-hole sink mixer, with "C" swivel spout, shorter model, luxury type.

CR



R42U
Miscelatore monocomando per lavello, con bocca alta a "U" girevole.
Single-lever one-hole sink mixer, with high "U" swivel spout.

CR



R41
Miscelatore monocomando per lavello a muro, con bocca girevole.
Single-lever wall mounted sink mixer, with swivel spout.

CR



R41S
Miscelatore monocomando per lavello a muro, con bocca a "S" girevole.
Single-lever wall mounted sink mixer, with "S" swivel spout.

CR



R43
Miscelatore monocomando per lavello a muro, con leva frontale e bocca alta girevole.
Single-lever wall mounted sink mixer, with frontal lever and high swivel spout.

CR



R43C
Miscelatore monocomando per lavello a muro, con leva frontale e bocca a "C" girevole, modello corto.
Single-lever wall mounted sink mixer, with frontal lever with "C" swivel spout, shorter model.

CR

RUBINETTERIA
TAPS

FLESSIBILI
FLEXIBLE HOSES

MINUTERIA
MINUTERY

VALVOLE
VALVES

RACCORDERIA
FITTINGS

ACCESSORI
ACCESSORIES

COMPONENTI PLASTICI
PLASTIC COMPONENTS

La serie è dotata di cartuccia a dischi ceramici Ø 35 mm.
The series is equipped with a Ø 35 mm ceramic disc cartridge.



OPZIONI MANIGLIA

La collezione è disponibile con diverse varianti di maniglia.
Selezionare la preferenza al momento dell'ordine.

LEVER OPTIONS

The collection is available with different lever options.
Select your preference before ordering.



LAVABI E BIDET - WASHBASIN AND BIDET MIXERS



F102SO

Miscelatore monocomando lavabo, con scarico.
Single-lever basin mixer, with pop-up waste.

CR



F102

Miscelatore monocomando lavabo, con scarico in plastica.
Single-lever basin mixer, with plastic pop-up waste.

CR



F112

Miscelatore monocomando lavabo, senza scarico.
Single-lever basin mixer, without waste.

CR



F202SO

Miscelatore monocomando per bidet, aeratore direzionabile, con scarico.
Single-lever bidet mixer with adjustable aerator, with pop-up waste.

CR



F202

Miscelatore monocomando per bidet, aeratore direzionabile, con scarico in plastica.
Single-lever bidet mixer with adjustable aerator, with plastic pop-up waste.

CR



F212

Miscelatore monocomando per bidet, con aeratore direzionabile senza scarico.
Single-lever bidet mixer with adjustable aerator, without waste.

CR



F112G

Miscelatore monocomando per lavabo o lavello, con bocca girevole.
Single-lever one-hole basin or sink mixer, with swivel spout, without waste.

CR



F232

Miscelatore monocomando per bidet, con doccetta spray.
Single-lever bidet mixer with spray.

CR

VASCA - BATH MIXERS



F072

Miscelatore monocomando bordo vasca serie Remix con deviatore integrato nella bocca, bocca fusa e doccetta estraibile ad 1 funzione.
Single lever deck bath/shower mixer with diverter integrated on the spout, casted spout, antilimestone pull-out handshower 1 function.

CR



91

Bocca incasso miscelatore vasca-doccia.
Built-in spout for bath-shower mixer.

CR



91D

Bocca incasso vasca-doccia, con deviatore integrato.
Built-in spout for bath-shower, with diverter.

CR



F022

Miscelatore monocomando per vasca esterno, con doccetta in ABS anticalcare ad 1 funzione e supporto snodato flessibile 150 cm.
Single-lever external bath mixer, with 1 function antilimestone ABS handshower and swivel shower holder, flexible hose 150 cm.

CR

F052

Miscelatore monocomando per vasca esterno, senza kit doccia.
Single-lever external bath mixer, without shower kit.

CR



F492

Miscelatore lavabo/vasca con canna fusa lunga e deviatore, con doccetta in ABS anticalcare ad 1 funzione e supporto snodato, flessibile 150 cm.
Wall basin/bath single lever mixer with long casted spout with diverter, with 1 function antilimestone ABS handshower and swivel shower holder, flexible hose 150 cm.

CR

F462

Miscelatore lavabo/vasca con canna fusa lunga e deviatore, senza kit doccia.
Wall basin/bath single lever mixer with long casted spout with diverter, without shower kit.

CR

**INCASSI DOCCIA
BUILT-IN MIXERS**



F302

Miscelatore monocomando incasso doccia completo.
Complete built-in single-lever shower mixer.

CR

N30B

Parte interna miscelatore monocomando incasso doccia.
Single-lever shower mixer (built-in components).

CR

F30E

Parte esterna miscelatore monocomando incasso doccia.
Single-lever shower mixer(external components).

CR

DOCCE - SHOWER MIXERS



F392

Miscelatore monocomando esterno doccia con doccetta in ABS anticalcare ad 1 funzione e supporto snodato flessibile 150 cm.
Wall mounted single-lever shower mixer with 1 function antilimestone ABS handshower and swivel shower holder, flexible hose 150 cm.

CR

F312

Miscelatore monocomando esterno doccia, senza kit doccia.
Wall mounted single-lever shower mixer, without shower kit.

CR



F382

Miscelatore monocomando esterno doccia con leva frontale, con doccetta in ABS anticalcare ad 1 funzione e supporto snodato flessibile 150 cm.
Wall mounted single-lever shower mixer with frontal lever, with 1 function antilimestone ABS handshower and swivel shower holder, flexible hose 150 cm.

CR

F332

Miscelatore monocomando esterno doccia con leva frontale, senza kit doccia.
Wall mounted single-lever shower mixer with frontal lever, without shower kit.

CR



F092

Miscelatore monocomando incasso vasca/doccia completo con deviatore.
Complete built-in single-lever bath/shower mixer with diverter.

CR

N09B

Parte interna miscelatore monocomando incasso vasca/doccia con deviatore.
Single-lever bath/shower mixer with diverter (built-in components).

CR

F09E

Parte esterna miscelatore monocomando incasso vasca/doccia con deviatore.
Single-lever bath/shower mixer with diverter (external components).

CR

CUCINA - KITCHEN

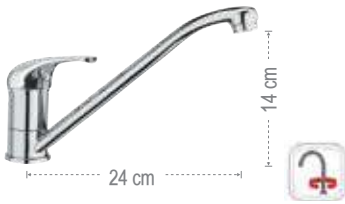

F402
Miscelatore monocomando per lavello, con bocca girevole.
Single-lever one-hole sink mixer, with swivel spout.

CR



F412
Miscelatore monocomando per lavello a muro, con bocca girevole.
Single-lever wall mounted sink mixer, with swivel spout.

CR



F412S
Miscelatore monocomando per lavello a muro, con bocca a "S" girevole.
Single-lever wall mounted sink mixer, with "S" swivel spout.

CR



F422
Miscelatore monocomando per lavello, con bocca alta girevole.
Single-lever one-hole sink mixer, with high swivel spout.

CR



F422C
Miscelatore monocomando per lavello, con bocca alta girevole, modello corto.
Single-lever one-hole sink mixer, with "C" swivel spout, shorter model.

CR



F422U
Miscelatore monocomando per lavello, con bocca alta a "U" girevole.
Single-lever one-hole sink mixer, with high "U" swivel spout.

CR



F422R
Miscelatore monocomando monoforo 90° per lavello, con bocca alta girevole ed orientabile, tipo lusso, modello sottofinestra.
Single-lever one-hole sink mixer, with swivel and orientable high spout, luxury type, under window type.

CR



F432
Miscelatore monocomando per lavello a muro, con leva frontale e bocca alta girevole.
Single-lever wall mounted sink mixer, with frontal lever and high swivel spout.

CR



F432C
Miscelatore monocomando per lavello a muro, con leva frontale e bocca a "C" girevole, modello corto.
Single-lever wall mounted sink mixer, with frontal lever and "C" swivel spout, shorter model.

CR

RUBINETTERIA
TAPS

FLESSIBILI
FLEXIBLE HOSES

MINUTERIA
MINUTERY

VALVOLE
VALVES

RACCORDERIA
FITTINGS

ACCESSORI
ACCESSORIES

COMPONENTI PLASTICI
PLASTIC COMPONENTS

LINEA MONO ACQUA - SINGLE WATER LINE

**F112GM**

Miscelatore monocomando e mono acqua per lavabo o lavello, con bocca girevole.
Single-lever single-water line basin or sink mixer, with swivel spout.

CR

**F402M**

Miscelatore monocomando mono acqua per lavello, con bocca girevole.
Single-lever single-water one-hole sink mixer, with swivel spout.

CR

**F422UM**

Miscelatore monocomando mono acqua per lavello, con bocca alta a "U" girevole.
Single-lever single water one-hole sink mixer, with high "U" swivel spout.

CR

**F422M**

Miscelatore monocomando mono acqua per lavello, con bocca alta girevole.
Single-lever single-water one-hole sink mixer, with high swivel spout.

CR

**F422CM**

Miscelatore monocomando mono acqua per lavello, con bocca a "C" girevole, tipo lusso, modello corto.
Single-lever single-water one-hole sink mixer, with "C" swivel spout, shorter model, luxury type.

CR

INTERASSE 100 CUCINA - INTERAXIS 100 KITCHEN

**C412**

Miscelatore monocomando per lavello a muro, con bocca girevole, interasse 100 mm.
Single-lever wall mounted sink mixer, with swivel spout, interaxis 100 mm.

CR

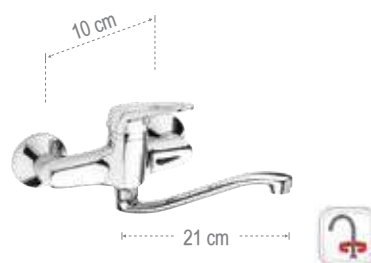
**C412S**

Miscelatore monocomando per lavello a muro, con bocca a "S" girevole, interasse 100 mm.
Single-lever wall mounted sink mixer, with "S" swivel spout, interaxis 100 mm.

CR

**C432**

Miscelatore monocomando per lavello a muro, con leva frontale e bocca alta girevole, interasse 100 mm.
Single-lever wall mounted sink mixer, with frontal lever and high swivel spout, interaxis 100 mm.

CR

INTERASSE 100mm - INTERAXIS 100mm



C492
 Miscelatore lavabo/vasca interasse 100 mm con canna fusa lunga 30 cm e deviatore, con doccetta in ABS anticalcare ad 1 funzione e supporto snodato, flessibile 150 cm.
 Wall basin/bath single lever mixer interaxis 100 mm with 30 cm long casted spout with diverter, with 1 function antilimestone ABS handshower and swivel shower holder, flexible hose 150 cm.

CR



C392
 Miscelatore monocomando esterno doccia, con interasse 100 mm, con doccetta in ABS anticalcare ad 1 funzione e supporto snodato flessibile 150 cm, con interasse 100 mm.
 Wall mounted single-lever shower mixer, interaxis 100 mm, with 1 function antilimestone ABS handshower and swivel shower holder, flexible hose 150 cm, interaxis 100 mm.

CR



C382
 Miscelatore monocomando esterno doccia con leva frontale, interasse 100 mm. Doccetta in ABS anticalcare ad 1 funzione e supporto snodato flessibile 150 cm, con interasse 100 mm.
 Wall mounted single-lever shower mixer with frontal lever, interaxis 100 mm. 1 function antilimestone ABS handshower and swivel shower holder, flexible hose 150 cm, interaxis 100 mm.

CR

C462
 Miscelatore lavabo/vasca interasse 100 mm con canna fusa lunga 30 cm e deviatore, senza kit doccia.
 Wall basin/bath single lever mixer interaxis 100 mm with 30 cm long casted spout with diverter, without shower kit.

CR

C312
 Miscelatore monocomando esterno doccia, con interasse 100 mm, senza kit doccia.
 Wall mounted single-lever shower mixer, interaxis 100 mm, without shower kit.

CR

C332
 Miscelatore monocomando esterno doccia con leva frontale, interasse 100 mm, senza kit doccia.
 Wall mounted single-lever shower mixer with frontal lever, interaxis 100 mm, without shower kit.

CR



C432C
 Miscelatore monocomando per lavello a muro, con leva frontale e bocca a "C" girevole, modello corto, interasse 100 mm.
 Single-lever wall mounted sink mixer, with frontal lever with "C" swivel spout, shorter model, interaxis 100 mm.

CR

RUBINETTERIA
TAPS

FLESSIBILI
FLEXIBLE HOSES

MINUTERIA
MINUTERY

VALVOLE
VALVES

RACCORDERIA
FITTINGS

ACCESSORI
ACCESSORIES

COMPONENTI PLASTICI
PLASTIC COMPONENTS

1000-2000

La serie è dotata di vitoni tradizionali.
The series is equipped with traditional headvalves.



OPZIONI MANIGLIA

La collezione è disponibile con diverse varianti di maniglia.
Selezionare la preferenza al momento dell'ordine.

LEVER OPTIONS

The collection is available with different lever options.
Select your preference before ordering.



LAVABI - WASHBASIN MIXERS



11EX
Batteria lavabo con scarico
Altezza bocca 6 cm, interasse 10 cm.
Wash basin mixer with pop-up waste.
Height spout 6 cm, Interaxis 10 cm.

EX - G

EG

CA - VI



12EX
Batteria lavabo senza scarico.
Altezza bocca 6 cm, interasse 10 cm.
Wash basin mixer without pop-up waste.
Height spout 6 cm, Interaxis 10 cm.

EX - G

CA - VI



13EX
Monoforo lavabo con scarico.
Altezza 12 cm, interasse 10 cm.
One-hole wash basin mixer with pop-up waste.
Height 12 cm, Interaxis 10 cm.

EX - G

EG

CA - VI

Y - YG



14EX
Gruppo lavabo tipo a ponte, canna Ø18 mm senza scarico.
Altezza 27 cm, interasse 22 cm.
Wash basin mixer bridge type, spout Ø18 mm without waste.
Height 27 cm, Interaxis 22 cm.

EX - G

CA - VI

Y - YG



14CEX
Gruppo lavabo tipo a ponte, canna alta a "C" senza scarico. Altezza 27 cm, interasse 22 cm.
Wash basin mixer bridge type, high "C" spout without waste. Height 27 cm, Interaxis 22 cm.

EX - G

CA - VI



17EX
Gruppo lavabo con interasse 160 mm e canna a jota Ø18 mm senza scarico. Altezza 27-28 cm, interasse 14,5 cm.
Wash basin mixer deck-mounted interaxis 160 mm. with jota spout Ø18 mm without waste. Height 27-28 cm, Interaxis 14,5 cm.

EX - G

CA - VI

Y - YG



15EX
Rubinetto collo cigno 1/2. Altezza bocca 6 cm, interasse 11 cm.
Wash basin pillar tap, 1/2.
Height spout 6 cm, Interaxis 11 cm.

EX - G

CA - VI

EG

BIDET - BIDET MIXERS



21EX
Combinazione bidet con scarico automatico.
Bidet mixer with pop-up waste.

EX - G

EG

CA - VI



22EX
Batteria bidet con doccia e scarico.
Bidet mixer with spray and pop-up waste.

EX - G

EG

CA - VI



23EX
Monoforo bidet con scarico.
Altezza bocca 8 cm, interasse 12 cm.
One-hole bidet mixer with pop-up waste 1"1/4.
Height spout 8 cm, Interaxis 12 cm.

EX - G

EG

CA - VI

Y - YG



3212EX
Rubinetto incasso a sfera removibile con maniglia, 1/2.
Built-in stop cock with reswivel ball valve, with handle, 1/2.

EX - G

EG

CA - VI



3234EX
Rubinetto incasso a sfera removibile con maniglia, 3/4.
Built-in stop cock with reswivel ball valve, with handle, 3/4.

EX - G

EG

CA - VI



31EX
Rubinetto incasso diritto 1/2.
Built-in stop cock, 1/2.

EX - G

EG

CA - VI



25EX
Rubinetto bidet 1/2.
Bidet tap 1/2.

EX - G

CA - VI



3312 1/2
Rubinetto incasso con cappuccio a 2 pezzi, 1/2.
Built-in stop cock with chromed cap in 2 pieces, 1/2.

3312 1/2



3412 1/2
Rubinetto incasso a sfera con cappuccio a 2 pezzi, 1/2, 3/4.
Built-in ball valve with chromed cap in 2 pieces, 1/2, 3/4.

3412 1/2

3434 3/4

RUBINETTERIA
TAPS

FLESSIBILI
FLEXIBLE HOSES

MINUTERIA
MINUTERY

VALVOLE
VALVES

RACCORDERIA
FITTINGS

ACCESSORI
ACCESSORIES

COMPONENTI PLASTICI
PLASTIC COMPONENTS

VASCA - BATH MIXERS



01EX

Gruppo vasca esterno con doccetta in ABS ad 1 funzione e flessibile 150 cm.
Bath tub mixer with ABS 1 function handshower and flexible hose 150 cm.

EX - G
EG
CA - VI
Y - YG



02EX

Gruppo vasca esterno con kit doccia duplex, doccetta in ABS ad 1 funzione, supporto snodato e flessibile 150 cm.
Bath tub mixer with duplex shower kit, with ABS 1 function handshower swivel shower holder and flexible hose 150 cm.

EX - G
EG
CA - VI
Y - YG



05EX

Gruppo vasca esterno senza kit doccia.
Bath tub mixer without shower kit.

EX - G
CA - VI
Y - YG



01SY

Gruppo vasca esterno con forcella singola, con doccetta in ABS ad 1 funzione e flessibile 150 cm.
Bath tub mixer, with single fork, with ABS 1 function handshower and flexible hose 150 cm.

Y

05SY

Gruppo vasca esterno con forcella singola, senza kit doccia.
Bath tub mixer, with single fork, without shower kit.

Y



02SY

Gruppo vasca esterno con doccia duplex, doccetta in ABS ad 1 funzione, supporto snodato e flessibile 150 cm forcella singola.
Bath tub mixer with duplex shower, with ABS 1 function handshower swivel shower holder and flexible hose 150 cm, with single fork.

Y

07EX

Gruppo vasca con deviatore e attacco superiore 3/4 M.
Bath tub mixer with diverter and 3/4 M upper connection.

EX - G
CA - VI
Y - YG



08EX

Gruppo vasca con colonna doccia 1/2x3/4 e soffione doccia standard.
Bath tub mixer with stand pipe 1/2x3/4 and standard shower rose.

EX - G
CA - VI
Y - YG



04EX

Gruppo vasca esterno con doccia duplex, doppia forcella, doccetta in ABS ad 1 funzione, supporto snodato e flessibile 150 cm; canna lunga girevole 40 cm.
Bathtub mixer with duplex shower with double fork and long swivel spout length 40 cm.

- EX - G
- CA - VI
- Y - YG



04SY

Gruppo vasca esterno con doccia duplex, doccetta in ABS ad 1 funzione, supporto snodato e flessibile 150 cm, canna lunga girevole 40 cm e forcella singola.
Bathtub mixer with duplex shower, with ABS 1 function handshower swivel shower holder and flexible hose 150 cm, long swivel spout length 40 cm, with single fork.

- Y

DOCCIA - SHOWER MIXERS

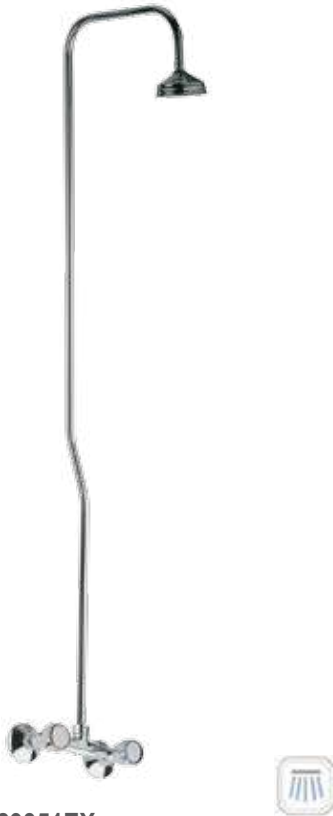

38EX329351EX

Miscelatore esterno doccia con attacco alto e colonna doccia 1/2x3/4 con soffione doccia standard.
Wall mounted shower mixer with higher connection with stand pipe 1/2x3/4 with standard shower head.

- EX

329EX351EX

Colonna doccia 1/2x3/4 e soffione doccia standard.
Stand pipe 1/2x3/4 and standard shower rose.
CR

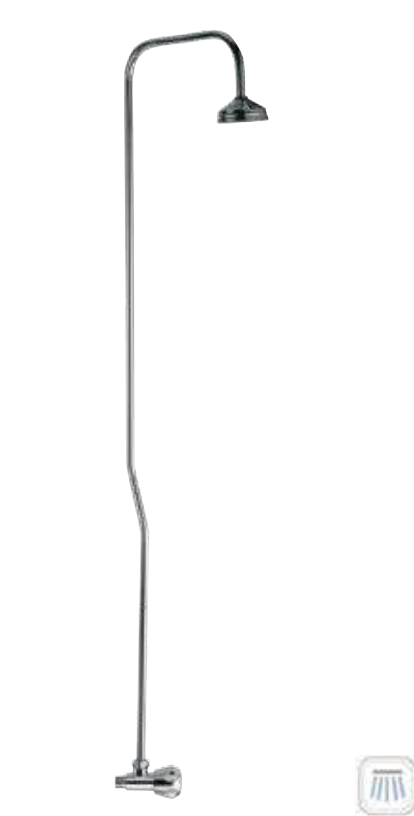

55EX329351EX

Colonna doccia 1/2x3/4 con soffione doccia standard e rubinetto a squadra.
Stand pipe 1/2x3/4 with standard shower head and angle tap.

- EX



39EX

Gruppo esterno per doccia, doccetta in ABS ad 1 funzione, supporto snodato e flessibile 150 cm.
Wall mounted shower mixer, with ABS 1 function handshower swivel shower holder and flexible hose 150 cm.

- EX - G
- CA - VI
- Y - YG

38EX

Gruppo esterno per doccia, senza kit doccia.
Wall mounted shower mixer without shower kit.

- EX - G
- CA - VI
- Y - YG

RUBINETTERIA
TAPS

FLESSIBILI
FLEXIBLE HOSES

MINUTERIA
MINUTERY

VALVOLE
VALVES

RACCORDERIA
FITTINGS

ACCESSORI
ACCESSORIES

COMPONENTI PLASTICI
PLASTIC COMPONENTS

CUCINA - KITCHEN

**41EX**

Gruppo lavello con canna inferiore girevole a "S", lunghezza canna 18 cm.
Sink mixer wall mounted, with low "S" swivel spout, length 18 cm.

EX - G

EG

CA - VI

Y - YG

**41SEX**

Gruppo lavello con canna superiore, unghetta canna 17,5 cm.
Sink mixer wall mounted, with upper swivel spout length 17,5 cm.

EX - G

CA - VI

Y - YG

**41JEX**

Gruppo lavello con canna alta girevole.
Altezza 25 cm, interasse 17 cm.
Sink mixer wall mounted, with high swivel spout.
Height 25 cm, Interaxis 17 cm.

EX - G

CA - VI

Y - YG

**42EX**

Gruppo lavello con attacco lavatrice, con canna inferiore lunga 18 cm.
Sink mixer with washing machine connection with low swivel spout length 18 cm.

EX - G

CA - VI

**43EX**

Monofofo lavello con canna girevole.
Altezza 26 cm, interasse 18 cm.
One-hole sink mixer with swivel spout.
Height 26 cm, Interaxis 18 cm.

EX - G

CA - VI

Y - YG

**43CEX**

Monofofo lavello con canna girevole, modello tipo corto. Altezza 21 cm, interasse 12 cm.
One-hole sink mixer with swivel spout, shorter model. Height 21 cm, Interaxis 12 cm.

EX - G

CA - VI

Y - YG

**45EX**

Monofofo lavello con canna girevole.
Altezza 23,5 cm, interasse 20,5 cm.
One-hole sink mixer with swivel spout.
Height 23,5 cm, Interaxis 20,5 cm.

EX - G

CA - VI

**46EX**

Monofofo lavello con deviatore lavastoviglie.
Altezza 28 cm, interasse 18 cm.
One-hole sink mixer with dish washer diverter and spout. Height 28 cm, Interaxis 18 cm.

EX - G

CA - VI

**47EX**

Monofofo lavello con doccia estraibile.
Altezza 17 cm, interasse 16 cm.
One-hole sink mixer with pull-out spray jet shower. Height 17 cm, Interaxis 16 cm.

EX - G

CA - VI

**48EX**

Gruppo miscelatore per boiler con canna girevole e due cannucce in rame cromato, 1/2.
Lunghezza canna 15,5 cm, interasse 15 cm.
Mixer for water heater with swiveling spout and two c.p. copper pipes, 1/2.
Length spout 15,5 cm, interaxis 15 cm.

EX - G

CA - VI

LINEA MONO ACQUA - SINGLE WATER LINE



51EX
Rubinetto prolungato, 1/2.
Wall mounted long tap, 1/2.

EX - G
CA - VI



52EX
Rubinetto con portagomma, 1/2.
Wall mounted hose-holder tap, 1/2.

EX - G
CA - VI
Y - YG



53EX
Rubinetto a snodo pesante, 1/2 canna Ø 18 mm lunghezza 21 cm.
Sink tap, with swivel spout Ø 18 lenght 18 cm, 1/2.

EX - G
CA - VI



53SEX
Rubinetto a snodo pesante, 1/2 con canna alta Ø18 girevole lunga 21 cm, con rompigitto.
Sink tap 1/2, with high swivel spout Ø18, and aerator.

EX - G
CA - VI
Y - YG



53JEX
Rubinetto a snodo pesante, 1/2 con canna alta a "J" Ø 18 girevole, con rompigitto.
Sink tap 1/2, with high "J" swivel spout Ø18, and aerator.

EX - G
CA - VI



54EX
Rubinetto monoforo per lavello con canna alta a "J" e rompigitto.
One-hole sink tap, with high "J" swivel spout and aerator.

EX - G
CA - VI
Y - YG



55EX
Rubinetto a squadra per lavatrice, 1/2x3/4.
Angle tap for washing machine 1/2x3/4.

EX - G
CA - VI



57EX
Rubinetto curvo con maniglia MINI Y.
Elbow tap with MINI Y handle, 1/2

EX - G
CA - VI



58EX
Rubinetto curvo con portagomma maniglia MINI Y, 1/2.
Elbow tap, with hose connection, with MINI Y handle, 1/2".

EX - G
CA - VI



250EX
Rubinetto a due maniglie per attacco lavatrice, 1/2" x 3/4".
Brass washing machine bibcock, heavy model, 1/2" x 3/4".

EX



2501234EX
Rubinetto a due maniglie per attacco lavatrice, 1/2" x 3/4" x 3/4".
Brass washing machine bibcock, heavy model, 1/2" x 3/4" x 3/4".

EX



252EX
Rubinetto a snodo con attacco lavatrice e bocca girevole lunga 17,5 cm, 1/2".
Brass washing machine bibcock, with swivel spout lenght 17,5 cm, 1/2".

EX



251EX
Rubinetto curvo con uscita da 1/2" e uscita da bocca di erogazione, attacco 1/2" M.
Angle tap with 1/2" output and spout output, 1/2" M connection.

EX

Y

EX

CA

MO



71Y

71YG



71EX

71G



71CA

71VI



71EG

Per ordinare solo la maniglia mettere il codice 71 + il codice della maniglia (es. 71EG)
To order only the handler insert code 71 +code of the handler (ex. 71EG)

RUBINETTERIA
TAPS

FLESSIBILI
FLEXIBLE HOSES

MINUTERIA
MINUTERY

VALVOLE
VALVES

RACCORDERIA
FITTINGS

ACCESSORI
ACCESSORIES

COMPONENTI PLASTICI
PLASTIC COMPONENTS

COMPLEMENTI DOCCIA

SHOWER COMPLEMENTS

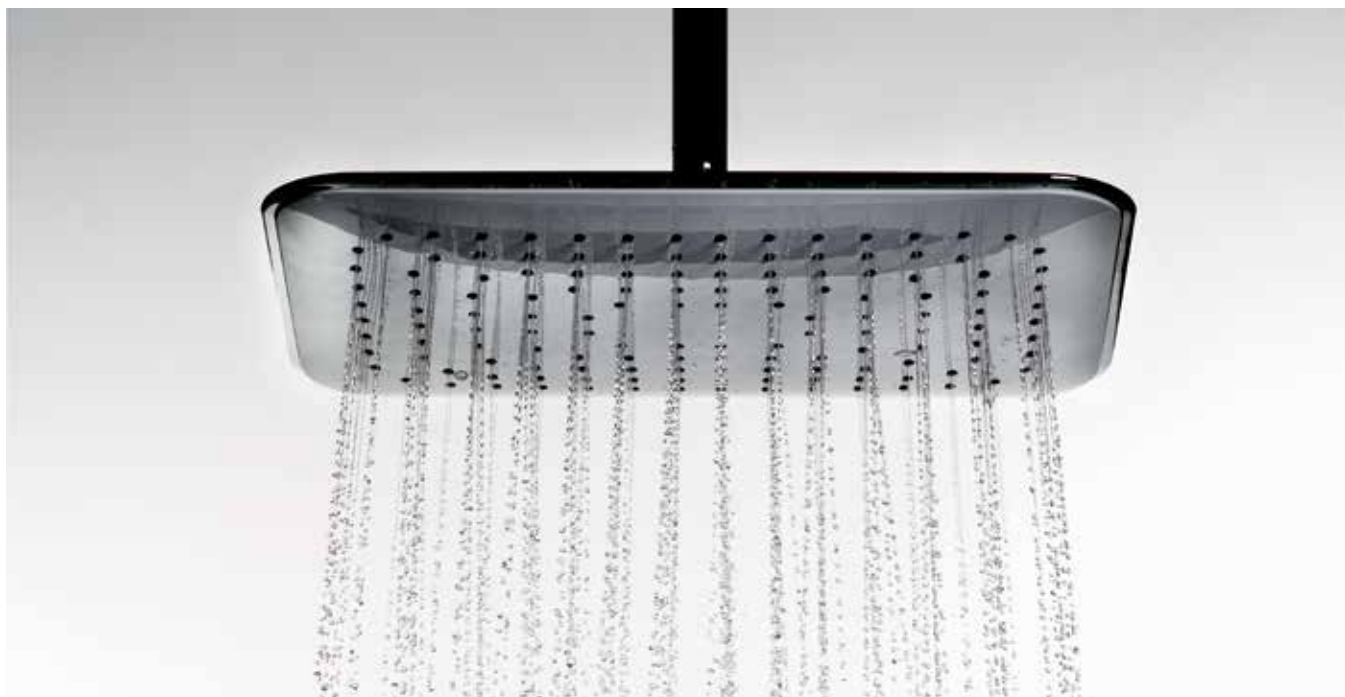

SOFFIONI IN ABS - ABS SHOWER HEADS



356V3X

Soffione a 3 funzioni con tasto centrale per il cambio dei getti: getto pioggia, nebulizzazione e misto, in ABS cromato, Ø 23 cm, con getti in silicone anticalcare.

C.p. ABS shower head, 3 functions with central button to change jets: rain, nebulization and mixed, Ø 23 cm, with antilimestone silicon jets.

CR



Soffione a pioggia Ø 15 cm, con getti anticalcare e snodo.

Shower-head "RAIN" Ø 15 cm, with antilimestone jet and ball-joint.

35315 Senza scatola - Without box

35315X Con scatola - With box



Soffione a pioggia Ø 23 cm, con getti anticalcare e snodo.

Shower-head "RAIN" Ø 23 cm, with antilimestone jet and ball-joint.

35323 Senza scatola - Without box

35323X Con scatola - With box



354PLX

Soffione a pioggia Ø 16 cm, con getti anticalcare e snodo.

Shower-head "Rain" Ø 16 cm, with antilimestone jet and ball-joint.

CR



Soffione con disco anticalcare, a snodo. Shower-head with antilimestone jet, with ball-joint.

351A Senza scatola - Without box

CR

351AX Con scatola - With box

CR



Soffione con disco ostaform, a snodo. Shower-head with ostaform disc, with ball-joint.

352 Senza scatola - Without box

CR

352X Con scatola - With box

CR

RUBINETTERIA - TAPS



Soffione cromato e satinato con disco anticalcare a snodo con 4 funzioni, autopulente.
Shower-head in chrome and satin, 4 functions antilimestone jet, with ball-joint, self cleaning.

358GR Senza scatola - Without box
CR

358GRX Con scatola - With box
CR



Soffione cromato con disco anticalcare a snodo con 3 funzioni, autopulente.
Shower-head in chrome, 3 functions, self cleaning.

358MO Senza scatola - Without box
CR

358MOX Con scatola - With box
CR



Soffione con disco anticalcare, autopulente, a snodo con 2 funzioni.
Shower-head with 2 functions, self-cleaning, antilimestone jet, with ball-joint

355FO Senza scatola - Without box
CR

355FOX Con scatola - With box
CR

DOCCETTE - HAND SHOWERS



Doccetta idromassaggio anticalcare a 2 funzioni in ABS.
2 functions ABS handshower, ydromassage, antilimestone.



315C3 Senza scatola - Without box
CR

315C3X Con scatola - With box
CR



Doccetta anticalcare idromassaggio a 3 funzioni.
C.P. handshower 3 functions, hydromassage, antilimestone.



315FO Senza scatola - Without box
CR

315FOX Con scatola - With box
CR



Doccetta idromassaggio anticalcare, 1 funzione.
1 function c.p. handshower antilimestone.



315C1 Senza scatola - Without box
CR

315C1X Con scatola - With box
CR



Doccetta idromassaggio anticalcare a 3 funzioni.
C.P. handshower 3 functions, hydromassage, antilimestone.



312RO Senza scatola - Without box
CR

312ROX Con scatola - With box
CR



Doccetta idromassaggio anticalcare a 3 funzioni.
C.P. handshower 3 functions, hydromassage, antilimestone



312OV Senza scatola - Without box
CR

312OVX Con scatola - With box
CR



Doccetta bianca ad 1 funzione, anticalcare.
White handshower 1 function, antilimestone.



311DABI Senza scatola - Without box
CR

311DABIX Con scatola - With box
CR

RUBINETTERIA
TAPS

FLESSIBILI
FLEXIBLE HOSES

MINUTERIA
MINUTERY

VALVOLE
VALVES

RACCORDERIA
FITTINGS

ACCESSORI
ACCESSORIES

COMPONENTI PLASTICI
PLASTIC COMPONENTS



Doccetta idromassaggio anticalcare a 5 funzioni.
C.P. handshower 5 functions hydromassage,
antilimestone.



321SC Senza scatola - Without box
CR

321SCX Con scatola - With box
CR



Doccetta cromata ad 1 funzione, anticalcare.
C.P. handshower 1 function, antilimestone.



311DA Senza scatola - Without box
CR

311DAX Con scatola - With box
CR



Doccetta in plastica cromata.
C.p. plastic handshower.



324CR Senza scatola - Without box
CR



Doccetta in plastica bianca e nera "Rombo".
Plastic handshower, coloured in black or white,
"Rhomb" shaped.



324 Senza scatola - Without box
CR



Doccetta in plastica cromata.
C.p. plastic handshower.



324ECR Senza scatola - Without box
CR

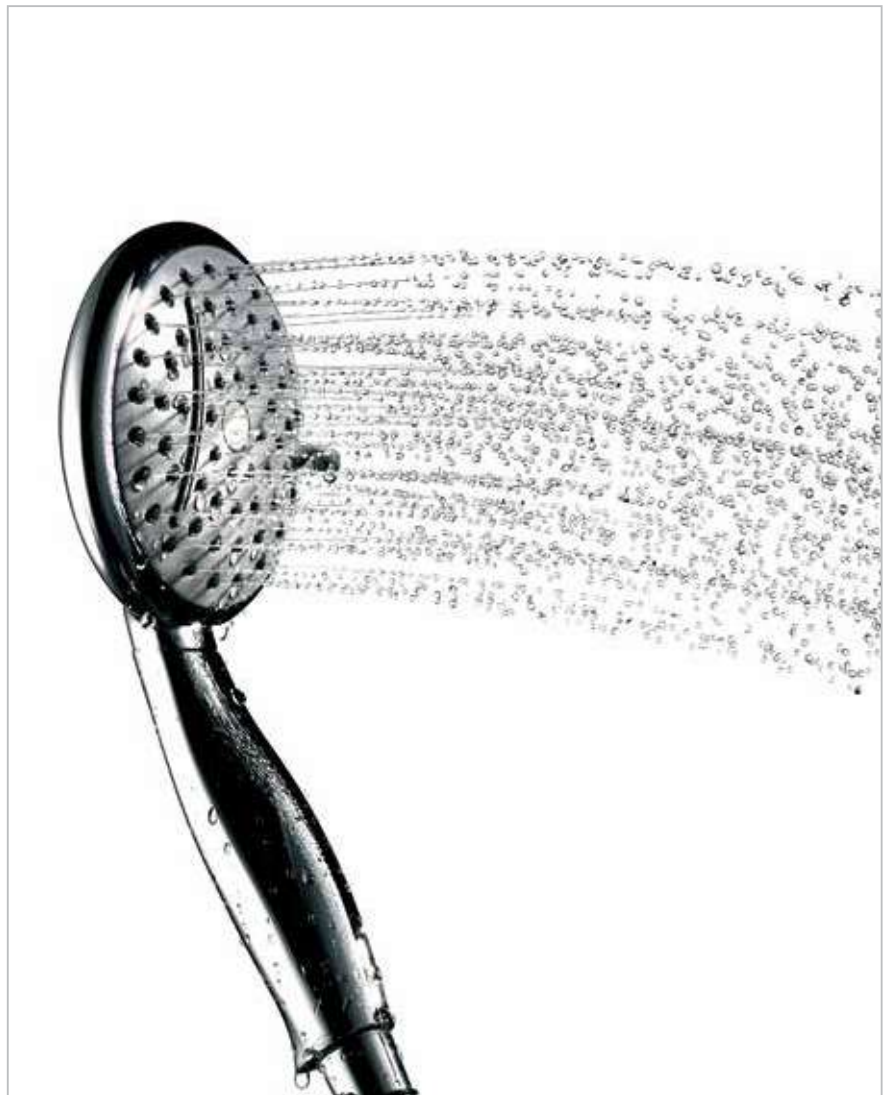

RUBINETTI - MIXERS



61
Rubinetto prolungato con comando a gomito, 1/2.
Wall mounted long tap, 1/2, with long lever.

CR



63
Rubinetto a snodo con comando a gomito, 1/2, con canna inferiore.
Wall mounted hose-holder tap, 1/2, with long lever and S inferior spout.

CR



64
Gruppo lavello con comando a gomito e canna inferiore.
Wall mounted mixer, with long levers and S inferior spout.

CR

RUBINETTERIA
TAPS

FLESSIBILI
FLEXIBLE HOSES

MINUTERIA
MINUTERY

VALVOLE
VALVES

RACCORDERIA
FITTINGS

ACCESSORI
ACCESSORIES

COMPONENTI PLASTICI
PLASTIC COMPONENTS



14LL
Gruppo lavello tipo a ponte con comando a gomito e canna Ø 18 mm.
Sink mixer bridge type, with long lever and spout Ø 18 mm.

CR



65
Rubinetto collo cigno con comando a gomito, 1/2.
Wash basin pillar tap, 1/2, with long lever.

CR



61LE
Leva in ottone per articoli 61, 63, 64, 65, 14LL.
Lever for art. 61, 63, 64, 65, 14LL.

CR



61VI
Vitone da 1/2 per articoli 61, 63, 64, 65, 14LL.
Head valve 1/2 for articles 61, 63, 64, 65, 14LL.

CR



FLESSIBILI FLEXIBLE HOSES



FLESSIBILI - FLEXIBLE HOSES



RUBINETTERIA
TAPS

FLESSIBILI
FLEXIBLE HOSES

MINUTERIA
MINUTERY

VALVOLE
VALVES

RACCORDERIA
FITTINGS

ACCESSORI
ACCESSORIES

COMPONENTI PLASTICI
PLASTIC COMPONENTS

FLESSIBILI DN 6 ACCIAIO INOX

FLESSIBILI PER RUBINETTERIA

STAINLESS STEEL DN 6 FLEXIBLES

FLEXIBLE HOSES FOR FAUCETS



DATI TECNICI - TECHNICAL DATA:

Tubo flessibile trecciato made in Italy in acciaio Inox AISI 304 con interno in gomma alimentare EPDM utilizzato per il collegamento tra la rete idrica e la rubinetteria sanitaria. Grazie alle dimensioni molto ridotte e alla pressatura su tutta la lunghezza della bussola, questo flessibile favorisce l'installazione su rubinetterie di qualsiasi design, specialmente quelle con un design molto minimale con degli spazi tecnici ridotti o poco accessibili. Tutti i flessibili sono raccordati con macchine automatiche ed il risultato è l'assoluta precisione di ogni pezzo prodotto per una garanzia di totale qualità.

Made in Italy braided hose in AISI 304 stainless steel with internal in non-toxic EPDM rubber, used for the connection between the water mains and the sanitary fittings. Thanks to the very small size and the pressing all along the entire length of the sleeve, this hose facilitates the installation on faucets of any design, especially on those with a very minimal design with reduced engineering spaces or not very accessible. All the hoses are produced with automatic machines and the result is the absolute precision of each produced piece for a total quality guarantee.

APPLICAZIONI - APPLICATIONS



MATERIALI - MATERIALS

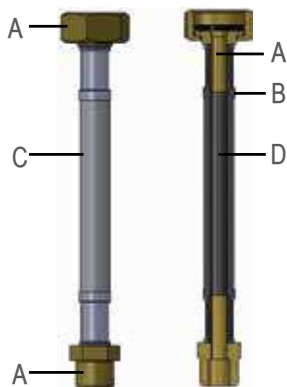

RACCORDI - FITTINGS:

- A) Ottone CW614N e CW617N nichelato o giallo
Brass CW614N and CW617N nickel plated or yellow

BUSSOLE - SLEEVES:

- B) Acciaio INOX AISI 304
Stainless steel AISI 304

TUBO - HOSE:

- C) Treccia 6 fili in acciaio INOX AISI 304
6 Wires Braid in steel INOX AISI 304
D) Tubo interno: gomma EPDM atossico
Internal pipe EPDM rubber, atoxic

CRATTERISTICHE - FEATURES



TEMPERATURA INSTALLAZIONE - INSTALLATION TEMPERATURE:

Da -5°C a +90°C - From -5°C to +90°C



PRESSIONE D'ESERCIZIO - WORKING PRESSURE:

10 BAR



PORTATA A 3 BAR - FLOW RATE AT 3 BAR:

19 lit/min



TEMPERATURA D'IMPIEGO - WORKING TEMPERATURE:

-5°C - +90°C



FORO MINIMO PASSAGGIO D'ACQUA - FITTING INNER DIAMETER:

4,7 mm



RAGGIO CURVATURA MINIMO - MINIMUM BENDING RADIUS:

25 mm



Ø INTERNO - INNER Ø:

Ø 6 mm



Ø ESTERNO - OUTER Ø:

Ø 10 mm



108P12F

Flessibile in Acciaio Inox AISI 304 - DN6 M10x1 - 1/2°F.
Stainless Steel Flexible hose AISI 304 - DN6 M10x1 - 1/2°F.

cm	20	25	30	35	40	45	50	60	80	100
----	----	----	----	----	----	----	----	----	----	-----



108LP12F

Flessibile in Acciaio Inox AISI 304 - DN6 ML10x1 - 1/2°F.
Stainless Steel Flexible hose AISI 304 - DN6 ML10x1 - 1/2°F.

cm	20	25	30	35	40	45	50	60	80	100
----	----	----	----	----	----	----	----	----	----	-----



108P38F

Flessibile in Acciaio Inox AISI 304 - DN6 M10x1 - 3/8°F.
Stainless Steel Flexible hose AISI 304 - DN6 M10x1 - 3/8°F.

cm	20	25	30	35	40	45	50	60	80	100
----	----	----	----	----	----	----	----	----	----	-----



108LP38F

Flessibile in Acciaio Inox AISI 304 - DN6 ML10x1 - 3/8°F.
Stainless Steel Flexible hose AISI 304 - DN6 ML10x1 - 3/8°F.

cm	20	25	30	35	40	45	50	60	80	100
----	----	----	----	----	----	----	----	----	----	-----



1088D12F

Flessibile in Acciaio Inox AISI 304 - DN6 M8x1 - 1/2°F.
Stainless Steel Flexible hose AISI 304 - DN6 M8x1 - 1/2°F.

cm	20	25	30	35	40	45	50	60	80	100
----	----	----	----	----	----	----	----	----	----	-----



108L8D12F

Flessibile in Acciaio Inox AISI 304 - DN6 ML8x1 - 1/2°F.
Stainless Steel Flexible hose AISI 304 - DN6 ML8x1 - 1/2°F.

cm	20	25	30	35	40	45	50	60	80	100
----	----	----	----	----	----	----	----	----	----	-----



1088D38F

Flessibile in Acciaio Inox AISI 304 - DN6 M8x1 - 3/8°F.
Stainless Steel Flexible hose AISI 304 - DN6 M8x1 - 3/8°F.

cm	20	25	30	35	40	45	50	60	80	100
----	----	----	----	----	----	----	----	----	----	-----



108L8D38F

Flessibile in Acciaio Inox AISI 304 - DN6 ML8x1 - 3/8°F.
Stainless Steel Flexible hose AISI 304 - DN6 ML8x1 - 3/8°F.

cm	20	25	30	35	40	45	50	60	80	100
----	----	----	----	----	----	----	----	----	----	-----

FLESSIBILI DN 8 ACCIAIO INOX

FLESSIBILI PER RUBINETTERIA E SANITARI

STAINLESS STEEL DN 8 FLEXIBLES

FLEXIBLES FOR FAUCETS AND SANITARIES



DATI TECNICI - TECHNICAL DATA:

Tubo flessibile trecciato made in Italy in acciaio Inox AISI 304 con interno in gomma alimentare EPDM utilizzato per il collegamento tra la rete idrica e la rubinetteria sanitaria o cassette W.C.e adatto a qualsiasi altro impiego sanitario. Tutti i flessibili sono raccordati con macchine automatiche ed il risultato è l'assoluta precisione di ogni pezzo prodotto per una garanzia di totale qualità.

Made in Italy braided hose in AISI 304 stainless steel with internal in EPDM rubber, used for the connection between the water mains and the sanitary fittings or W.C. flushing tanks. All the hoses are produced with automatic machines and the result is the absolute precision of each produced piece for a total quality guarantee.

APPLICAZIONI - APPLICATIONS



MATERIALI - MATERIALS

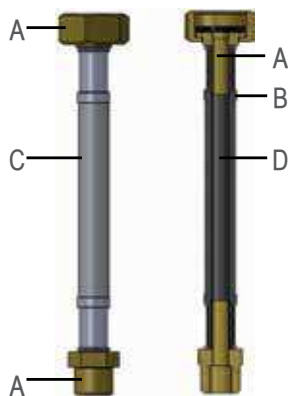

RACCORDI - FITTINGS:

- A) Ottone CW614N e CW617N nichelato
Brass CW614N and CW617N nickel plated

BUSSOLE - SLEEVES:

- B) Acciaio INOX AISI 304
Stainless steel AISI 304

TUBO - HOSE:

- C) Treccia 7 fili in acciaio INOX AISI 304
7 Wires Braid in steel INOX AISI 304
D) Tubo interno: gomma EPDM atossico
Internal pipe EPDM rubber, atoxic

CRATTERISTICHE - FEATURES



TEMPERATURA INSTALLAZIONE - INSTALLATION TEMPERATURE:

Da -5°C a +90°C - From -5°C to +90°C



PRESSIONE D'ESERCIZIO - WORKING PRESSURE:

10 BAR



PORTATA A 3 BAR - FLOW RATE AT 3 BAR:

29 lit/min



TEMPERATURA D'IMPIEGO - WORKING TEMPERATURE:

-5°C - +90°C



FORO MINIMO PASSAGGIO D'ACQUA - FITTING INNER DIAMETER:

6 mm



RAGGIO CURVATURA MINIMO - MINIMUM BENDING RADIUS:

30 mm



Ø INTERNO - INNER Ø:

Ø 8 mm



Ø ESTERNO - OUTER Ø:

Ø 12 mm



10812F

Flessibile in Acciaio Inox AISI 304 - DN8 M10x1 - 1/2°F.
Stainless Steel Flexible hose AISI 304 - DN8 M10x1 - 1/2°F.

cm	20	25	30	35	40	45	50	60	80	100
----	----	----	----	----	----	----	----	----	----	-----



10838F

Flessibile in Acciaio Inox AISI 304 - DN8 M10x1 - 3/8°F.
Stainless Steel Flexible hose AISI 304 - DN8 M10x1 - 3/8°F.

cm	20	25	30	35	40	45	50	60	80	100
----	----	----	----	----	----	----	----	----	----	-----



108XL12F

Flessibile in Acciaio Inox AISI 304 - DN8 MXL10x1 - 1/2°F.
Stainless Steel Flexible hose AISI 304 - DN8 MXL10x1 - 1/2°F.

cm	20	25	30	35	40	45	50	60	80	100
----	----	----	----	----	----	----	----	----	----	-----



108L12F

Flessibile in Acciaio Inox AISI 304 - DN8 ML10x1 - 1/2°F.
Stainless Steel Flexible hose AISI 304 - DN8 ML10x1 - 1/2°F.

cm	20	25	30	35	40	45	50	60	80	100
----	----	----	----	----	----	----	----	----	----	-----



108L38F

Flessibile in Acciaio Inox AISI 304 - DN8 ML10x1 - 3/8°F.
Stainless Steel Flexible hose AISI 304 - DN8 ML10x1 - 3/8°F.

cm	20	25	30	35	40	45	50	60	80	100
----	----	----	----	----	----	----	----	----	----	-----



108XL38F

Flessibile in Acciaio Inox AISI 304 - DN8 MXL10x1 - 3/8°F.
Stainless Steel Flexible hose AISI 304 - DN8 MXL10x1 - 3/8°F.

cm	20	25	30	35	40	45	50	60	80	100
----	----	----	----	----	----	----	----	----	----	-----



10812D12F

Flessibile in Acciaio Inox AISI 304 - DN8 M12x1 - 1/2°F.
Stainless Steel Flexible hose AISI 304 - DN8 M12x1 - 1/2°F.

cm	20	25	30	35	40	45	50	60	80	100
----	----	----	----	----	----	----	----	----	----	-----



108L12D12F

Flessibile in Acciaio Inox AISI 304 - DN8 ML12x1 - 1/2°F.
Stainless Steel Flexible hose AISI 304 - DN8 ML12x1 - 1/2°F.

cm	20	25	30	35	40	45	50	60	80	100
----	----	----	----	----	----	----	----	----	----	-----



10812D38F

Flessibile in Acciaio Inox AISI 304 - DN8 M12x1 - 3/8°F.
Stainless Steel Flexible hose AISI 304 - DN8 M12x1 - 3/8°F.

cm	20	25	30	35	40	45	50	60	80	100
----	----	----	----	----	----	----	----	----	----	-----



108L12D38F

Flessibile in Acciaio Inox AISI 304 - DN8 ML12x1 - 3/8°F.
Stainless Steel Flexible hose AISI 304 - DN8 ML12x1 - 3/8°F.

cm	20	25	30	35	40	45	50	60	80	100
----	----	----	----	----	----	----	----	----	----	-----



108TB

Flessibile in Acciaio Inox AISI 304 - DN8 M10x1 - TB10 mm.
Stainless Steel Flexible hose AISI 304 - DN8 M10x1 - TB 10mm.

cm	20	25	30	35	40	45	50	60	80	100
----	----	----	----	----	----	----	----	----	----	-----



108LTB

Flessibile in Acciaio Inox AISI 304 - DN8 ML10x1 - TB10 mm.
Stainless Steel Flexible hose AISI 304 - DN8 ML10x1 - TB10 mm.

cm	20	25	30	35	40	45	50	60	80	100
----	----	----	----	----	----	----	----	----	----	-----

RUBINETTERIA
TAPS

FLESSIBILI
FLEXIBLE HOSES

MINUTERIA
MINUTERY

VALVOLE
VALVES

RACCORDERIA
FITTINGS

ACCESSORI
ACCESSORIES

COMPONENTI PLASTICI
PLASTIC COMPONENTS



10812F12F

Flessibile in Acciaio Inox AISI 304 - DN8 1/2°F - 1/2°F.
Stainless Steel Flexible hose AISI 304 - DN8 1/2°F - 1/2°F.

cm	20	25	30	35	40	45	50	60	80	100
----	----	----	----	----	----	----	----	----	----	-----



10812M12F

Flessibile in Acciaio Inox AISI 304 - DN8 1/2°M - 1/2°F.
Stainless Steel Flexible hose AISI 304 - DN8 1/2°M - 1/2°F.

cm	20	25	30	35	40	45	50	60	80	100
----	----	----	----	----	----	----	----	----	----	-----



10838F38F

Flessibile in Acciaio Inox AISI 304 - DN8 3/8°F - 3/8°F.
Stainless Steel Flexible hose AISI 304 - DN8 3/8°F - 3/8°F.

cm	20	25	30	35	40	45	50	60	80	100
----	----	----	----	----	----	----	----	----	----	-----



10838M38F

Flessibile in Acciaio Inox AISI 304 - DN8 3/8°M - 3/8°F.
Stainless Steel Flexible hose AISI 304 - DN8 3/8°M - 3/8°F.

cm	20	25	30	35	40	45	50	60	80	100
----	----	----	----	----	----	----	----	----	----	-----



10812F38F

Flessibile in Acciaio Inox AISI 304 - DN8 1/2°F - 3/8°F.
Stainless Steel Flexible hose AISI 304 - DN8 1/2°F - 3/8°F.

cm	20	25	30	35	40	45	50	60	80	100
----	----	----	----	----	----	----	----	----	----	-----



10812M38F

Flessibile in Acciaio Inox AISI 304 - DN8 1/2°M - 3/8°F.
Stainless Steel Flexible hose AISI 304 - DN8 1/2°M - 3/8°F.

cm	20	25	30	35	40	45	50	60	80	100
----	----	----	----	----	----	----	----	----	----	-----



10838M12F

Flessibile in Acciaio Inox AISI 304 - DN8 3/8°M - 1/2°F.
Stainless Steel Flexible hose AISI 304 - DN8 3/8°M - 1/2°F.

cm	20	25	30	35	40	45	50	60	80	100
----	----	----	----	----	----	----	----	----	----	-----



10810BTB

Flessibile in Acciaio Inox AISI 304 - DN8 10B - TB10 mm.
Stainless Steel Flexible hose AISI 304 - DN8 10B - TB10 mm.

cm	20	25	30	35	40	45	50	60	80	100
----	----	----	----	----	----	----	----	----	----	-----



10810B12F

Flessibile in Acciaio Inox AISI 304 - DN8 10B - 1/2°F.
Stainless Steel Flexible hose AISI 304 - DN8 10B - 1/2°F.

cm	20	25	30	35	40	45	50	60	80	100
----	----	----	----	----	----	----	----	----	----	-----



10810B38F

Flessibile in Acciaio Inox AISI 304 - DN8 10B - 3/8°F.
Stainless Steel Flexible hose AISI 304 - DN8 10B - 3/8°F.

cm	20	25	30	35	40	45	50	60	80	100
----	----	----	----	----	----	----	----	----	----	-----



10810B12M

Flessibile in Acciaio Inox AISI 304 - DN8 10B - 1/2°M.
Stainless Steel Flexible hose AISI 304 - DN8 10B - 1/2°M.

cm	20	25	30	35	40	45	50	60	80	100
----	----	----	----	----	----	----	----	----	----	-----



10810B38M

Flessibile in Acciaio Inox AISI 304 - DN8 10B - 3/8°M.
Stainless Steel Flexible hose AISI 304 - DN8 10B - 3/8°M.

cm	20	25	30	35	40	45	50	60	80	100
----	----	----	----	----	----	----	----	----	----	-----

FLESSIBILI DN 10 ACCIAIO INOX

FLESSIBILI PER SANITARI

STAINLESS STEEL DN 10 FLEXIBLES

FLEXIBLES FOR SANITARIES



DATI TECNICI - TECHNICAL DATA:

Tubo flessibile trecciato made in Italy in acciaio Inox AISI 304 con interno in gomma alimentare EPDM utilizzato prevalentemente per il collegamento tra la rete idrica e i rubinetti singoli, gli scaldabagni, le pareti doccia attrezzate e le vasche idromassaggio oltre che ai rubinetti posti sulle cucine industriali. Tutti i flessibili sono raccordati con macchine automatiche ed il risultato è l'assoluta precisione di ogni pezzo prodotto per una garanzia di totale qualità.

Made in Italy braided hose in AISI 304 stainless steel with internal in non-toxic EPDM rubber, mainly used for the connection between the water mains and the single faucet, the boilers, the equipped shower sets and the hydromassage tubs, besides the taps are placed on industrial kitchens. All the hoses are produced with automatic machines and the result is the absolute precision of each produced piece for a total quality guarantee.

APPLICAZIONI - APPLICATIONS



MATERIALI - MATERIALS

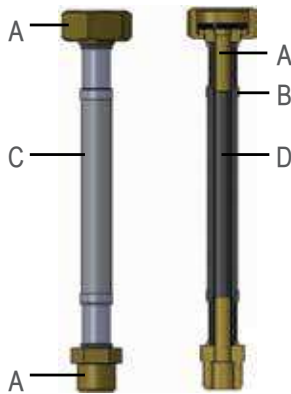

RACCORDI - FITTINGS:

- A) Ottone CW614N e CW617N nichelato
Brass CW614N and CW617N nickel plated

BUSSOLE - SLEEVES:

- B) Acciaio INOX AISI 304
Stainless steel AISI 304

TUBO - HOSE:

- C) Treccia 7-8 fili in acciaio INOX AISI 304
7-8 Wires Braid in steel INOX AISI 304
D) Tubo interno: gomma EPDM atossico
Internal pipe EPDM rubber, atoxic

CRATTERISTICHE - FEATURES



TEMPERATURA INSTALLAZIONE - INSTALLATION TEMPERATURE:

Da -5°C a +90°C - From -5°C to +90°C



PRESSIONE D'ESERCIZIO - WORKING PRESSURE:

10 BAR



PORTATA A 3 BAR - FLOW RATE AT 3 BAR:

42 lit/min



TEMPERATURA D'IMPIEGO - WORKING TEMPERATURE:

-5°C - +90°C



FORO MINIMO PASSAGGIO D'ACQUA - FITTING INNER DIAMETER:

7 mm



RAGGIO CURVATURA MINIMO - MINIMUM BENDING RADIUS:

30 mm



Ø INTERNO - INNER Ø:

Ø 10 mm



Ø ESTERNO - OUTER Ø:

Ø 14 mm

RUBINETTERIA
TAPSFLESSIBILI
FLEXIBLE HOSESMINUTERIA
MINUTERYVALVOLE
VALVESRACCORDERIA
FITTINGSACCESSORI
ACCESSORIESCOMPONENTI PLASTICI
PLASTIC COMPONENTS

DN10

10012F12F



Flessibile in Acciaio Inox AISI 304 - DN10 1/2°F - 1/2°F.
Stainless Steel Flexible hose AISI 304 - DN10 1/2°F - 1/2°F.

cm	20	25	30	35	40	45	50	60	80	100
----	----	----	----	----	----	----	----	----	----	-----

10012M12F



Flessibile in Acciaio Inox AISI 304 - DN10 1/2°M - 1/2°F.
Stainless Steel Flexible hose AISI 304 - DN10 1/2°M - 1/2°F.

cm	20	25	30	35	40	45	50	60	80	100
----	----	----	----	----	----	----	----	----	----	-----

10038F38F



Flessibile in Acciaio Inox AISI 304 - DN10 3/8°F - 3/8°F.
Stainless Steel Flexible hose AISI 304 - DN10 3/8°F - 3/8°F.

cm	20	25	30	35	40	45	50	60	80	100
----	----	----	----	----	----	----	----	----	----	-----

10038M38F



Flessibile in Acciaio Inox AISI 304 - DN10 3/8°M - 3/8°F.
Stainless Steel Flexible hose AISI 304 - DN10 3/8°M - 3/8°F.

cm	20	25	30	35	40	45	50	60	80	100
----	----	----	----	----	----	----	----	----	----	-----

10012F38F



Flessibile in Acciaio Inox AISI 304 - DN10 1/2°F - 3/8°F.
Stainless Steel Flexible hose AISI 304 - DN10 1/2°F - 3/8°F.

cm	20	25	30	35	40	45	50	60	80	100
----	----	----	----	----	----	----	----	----	----	-----

10038M12F



Flessibile in Acciaio Inox AISI 304 - DN10 3/8°M - 1/2°F.
Stainless Steel Flexible hose AISI 304 - DN10 3/8°M - 1/2°F.

cm	20	25	30	35	40	45	50	60	80	100
----	----	----	----	----	----	----	----	----	----	-----

10012M38F



Flessibile in Acciaio Inox AISI 304 - DN10 1/2°M - 3/8°F.
Stainless Steel Flexible hose AISI 304 - DN10 1/2°M - 3/8°F.

cm	20	25	30	35	40	45	50	60	80	100
----	----	----	----	----	----	----	----	----	----	-----

10034M12F



Flessibile in Acciaio Inox AISI 304 - DN10 3/4°M - 1/2°F.
Stainless Steel Flexible hose AISI 304 - DN10 3/4°M - 1/2°F.

cm	20	25	30	35	40	45	50	60	80	100
----	----	----	----	----	----	----	----	----	----	-----

10012F34F



Flessibile in Acciaio Inox AISI 304 - DN10 1/2°F - 3/4°F.
Stainless Steel Flexible hose AISI 304 - DN10 1/2°F - 3/4°F.

cm	20	25	30	35	40	45	50	60	80	100
----	----	----	----	----	----	----	----	----	----	-----

10012M34F



Flessibile in Acciaio Inox AISI 304 - DN10 1/2°M - 3/4°F.
Stainless Steel Flexible hose AISI 304 - DN10 1/2°M - 3/4°F.

cm	20	25	30	35	40	45	50	60	80	100
----	----	----	----	----	----	----	----	----	----	-----

10034F34F



Flessibile in Acciaio Inox AISI 304 - DN10 3/4°F - 3/4°F.
Stainless Steel Flexible hose AISI 304 - DN10 3/4°F - 3/4°F.

cm	20	25	30	35	40	45	50	60	80	100
----	----	----	----	----	----	----	----	----	----	-----

10034M34F



Flessibile in Acciaio Inox AISI 304 - DN10 3/4°M - 3/4°F.
Stainless Steel Flexible hose AISI 304 - DN10 3/4°M - 3/4°F.

cm	20	25	30	35	40	45	50	60	80	100
----	----	----	----	----	----	----	----	----	----	-----

100C12F12F



Flessibile in Acciaio Inox AISI 304 - DN10 1/2°F - 1/2°F.
Stainless Steel Flexible hose AISI 304 - DN10 1/2°F - 1/2°F.

cm	20	25	30	35	40	45	50	60	80	100
----	----	----	----	----	----	----	----	----	----	-----

100C12M12F



Flessibile in Acciaio Inox AISI 304 - DN10 1/2°M - 1/2°F.
Stainless Steel Flexible hose AISI 304 - DN10 1/2°M - 1/2°F.

cm	20	25	30	35	40	45	50	60	80	100
----	----	----	----	----	----	----	----	----	----	-----

100C12F34F



Flessibile in Acciaio Inox AISI 304 - DN10 1/2°F - 3/4°F.
Stainless Steel Flexible hose AISI 304 - DN10 1/2°F - 3/4°F.

cm	20	25	30	35	40	45	50	60	80	100
----	----	----	----	----	----	----	----	----	----	-----

100C12M34F



Flessibile in Acciaio Inox AISI 304 - DN10 1/2°M - 3/4°F.
Stainless Steel Flexible hose AISI 304 - DN10 1/2°M - 3/4°F.

cm	20	25	30	35	40	45	50	60	80	100
----	----	----	----	----	----	----	----	----	----	-----

FLESSIBILI - FLEXIBLE HOSES

100C34F12F

Flessibile in Acciaio Inox AISI 304 - DN10 3/4"F - 1/2"FC.
Stainless Steel Flexible hose AISI 304 - DN10 3/4"F - 1/2"FC.

cm	20	25	30	35	40	45	50	60	80	100
----	----	----	----	----	----	----	----	----	----	-----



100C34M12F

Flessibile in Acciaio Inox AISI 304 - DN10 3/4"M - 1/2"FC.
Stainless Steel Flexible hose AISI 304 - DN10 3/4"M - 1/2"FC.

cm	20	25	30	35	40	45	50	60	80	100
----	----	----	----	----	----	----	----	----	----	-----



100C38F12F

Flessibile in Acciaio Inox AISI 304 - DN10 3/8"F - 1/2"FC.
Stainless Steel Flexible hose AISI 304 - DN10 3/8"F - 1/2"FC.

cm	20	25	30	35	40	45	50	60	80	100
€	6,30	6,40	6,60	6,80	7,00	7,10	7,30	7,90	8,60	9,40



100C38M12F

Flessibile in Acciaio Inox AISI 304 DN10 - 3/8"M - 1/2"FC.
Stainless Steel Flexible hose AISI 304 DN10 - 3/8"M - 1/2"FC.

cm	20	25	30	35	40	45	50	60	80	100
€	6,30	6,40	6,60	6,80	7,00	7,10	7,30	7,90	8,60	9,40



100C34F34F

Flessibile in Acciaio Inox AISI 304 - DN10 3/4"F - 3/4"FC.
Stainless Steel Flexible hose AISI 304 - DN10 3/4"F - 3/4"FC.

cm	20	25	30	35	40	45	50	60	80	100
----	----	----	----	----	----	----	----	----	----	-----



100C34M34F

Flessibile in Acciaio Inox AISI 304 - DN10 3/4"M - 3/4"FC.
Stainless Steel Flexible hose AISI 304 - DN10 3/4"M - 3/4"FC.

cm	20	25	30	35	40	45	50	60	80	100
----	----	----	----	----	----	----	----	----	----	-----



10312M12F

Flessibile in Acciaio Inox AISI 304 - DN10 1/2"ML - 1/2"F.
Stainless Steel Flexible hose AISI 304 - DN10 1/2"ML - 1/2"F.

cm	20	25	30	35	40	45	50	60	80	100
----	----	----	----	----	----	----	----	----	----	-----



10338M38F

Flessibile in Acciaio Inox AISI 304 - DN10 3/8"ML - 3/8"F.
Stainless Steel Flexible hose AISI 304 - DN10 3/8"ML - 3/8"F.

cm	20	25	30	35	40	45	50	60	80	100
----	----	----	----	----	----	----	----	----	----	-----



10338M12F

Flessibile in Acciaio Inox AISI 304 - DN10 3/8"ML - 1/2"F.
Stainless Steel Flexible hose AISI 304 - DN10 3/8"ML - 1/2"F.

cm	20	25	30	35	40	45	50	60	80	100
----	----	----	----	----	----	----	----	----	----	-----



10312M38F

Flessibile in Acciaio Inox AISI 304 - DN10 1/2"ML - 3/8"F.
Stainless Steel Flexible hose AISI 304 - DN10 1/2"ML - 3/8"F.

cm	20	25	30	35	40	45	50	60	80	100
----	----	----	----	----	----	----	----	----	----	-----



10612F

Flessibile in Acciaio Inox AISI 304 - DN10 10B - 1/2"F.
Stainless Steel Flexible hose AISI 304 - DN10 10B - 1/2"F.

cm	20	25	30	35	40	45	50	60	80	100
----	----	----	----	----	----	----	----	----	----	-----



10612M

Flessibile in Acciaio Inox AISI 304 - DN10 10B - 1/2"M.
Stainless Steel Flexible hose AISI 304 - DN10 10B - 1/2"M.

cm	20	25	30	35	40	45	50	60	80	100
----	----	----	----	----	----	----	----	----	----	-----



10638F

Flessibile in Acciaio Inox AISI 304 - DN10 10B - 3/8"F.
Stainless Steel Flexible hose AISI 304 - DN10 10B - 3/8"F.

cm	20	25	30	35	40	45	50	60	80	100
----	----	----	----	----	----	----	----	----	----	-----



10638M

Flessibile in Acciaio Inox AISI 304 - DN10 10B - 3/8"M.
Stainless Steel Flexible hose AISI 304 - DN10 10B - 3/8"M.

cm	20	25	30	35	40	45	50	60	80	100
----	----	----	----	----	----	----	----	----	----	-----



RUBINETTERIA
TAPS

FLESSIBILI
FLEXIBLE HOSES

MINUTERIA
MINUTERY

VALVOLE
VALVES

RACCORDERIA
FITTINGS

ACCESSORI
ACCESSORIES

COMPONENTI PLASTICI
PLASTIC COMPONENTS

FLESSIBILI DN 13 ACCIAIO INOX

FLESSIBILI PER SCALDABAGNO,
CALDAIE ED ELETTRODOMESTICI

STAINLESS STEEL DN 13 FLEXIBLES

FLEXIBLES HOSES FOR WATER HEATERS,
BOILERS AND HOUSEHOLD APPLIANCES



DATI TECNICI - TECHNICAL DATA:

Tubo flessibile trecciato made in Italy in acciaio Inox AISI 304 con interno in gomma alimentare EPDM utilizzato prevalentemente per il collegamento tra la rete idrica e i rubinetti singoli, gli scaldabagni, le pareti doccia attrezzate e le vasche idromassaggio oltre che ai rubinetti posti sulle cucine industriali. Tutti i flessibili sono raccordati con macchine automatiche ed il risultato è l'assoluta precisione di ogni pezzo prodotto per una garanzia di totale qualità.

Made in Italy braided hose in AISI 304 stainless steel with internal in non-toxic EPDM rubber, mainly used for the connection between the water mains and the single faucet, the boilers, the equipped shower sets and the hydromassage tubs, besides the taps are placed on industrial kitchens. All the hoses are produced with automatic machines and the result is the absolute precision of each produced piece for a total quality guarantee.

APPLICAZIONI - APPLICATIONS



MATERIALI - MATERIALS

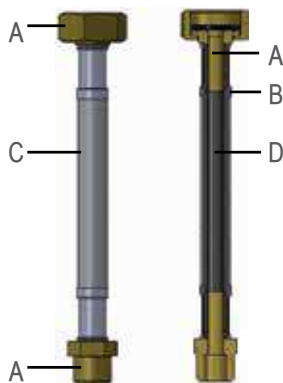

RACCORDI - FITTINGS:
A) CW617N nichelato o giallo
Brass CW617N nickel plated or yellow

BUSSOLE - SLEEVES:
B) Acciaio INOX AISI 304
Stainless steel AISI 304

TUBO - HOSE:
C) Treccia 9 fili in acciaio INOX AISI 304
9 Wires Braid in steel INOX AISI 304
D) Tubo interno: gomma EPDM atossico
Internal pipe EPDM rubber, atoxic

CRATTERISTICHE - FEATURES



TEMPERATURA INSTALLAZIONE - INSTALLATION TEMPERATURE:

Da -5°C a +90°C - From -5°C to +90°C



PRESSIONE D'ESERCIZIO - WORKING PRESSURE:

16 BAR



PORTATA A 3 BAR - FLOW RATE AT 3 BAR:

65 lit/min



TEMPERATURA D'IMPIEGO - WORKING TEMPERATURE:

-5°C - +90°C



FORO MINIMO PASSAGGIO D'ACQUA - FITTING INNER DIAMETER:

9,3 mm



RAGGIO CURVATURA MINIMO - MINIMUM BENDING RADIUS:

45 mm



Ø INTERNO - INNER Ø:

Ø 13 mm



Ø ESTERNO - OUTER Ø:

Ø 18 mm

11612F12F

Flessibile in Acciaio Inox AISI 304 - DN13 1/2"F - 1/2"F
Stainless Steel Flexible hose AISI 304 - DN13 1/2"F - 1/2"F

cm	20	25	30	35	40	45	50	60	80	100
----	----	----	----	----	----	----	----	----	----	-----

11612M12F

Flessibile in Acciaio Inox AISI 304 - DN13 1/2"M - 1/2"F
Stainless Steel Flexible hose AISI 304 - DN13 1/2"M - 1/2"F

cm	20	25	30	35	40	45	50	60	80	100
----	----	----	----	----	----	----	----	----	----	-----



11634F34F

Flessibile in Acciaio Inox AISI 304 - DN13 3/4" F - 3/4" F
Stainless Steel Flexible hose AISI 304 - DN13 3/4" F - 3/4" F

cm	20	25	30	35	40	45	50	60	80	100
----	----	----	----	----	----	----	----	----	----	-----



11634M34F

Flessibile in Acciaio Inox AISI 304 - DN13 3/4" M - 3/4" F
Stainless Steel Flexible hose AISI 304 - DN13 3/4" M - 3/4" F

cm	20	25	30	35	40	45	50	60	80	100
----	----	----	----	----	----	----	----	----	----	-----



11612F34F

Flessibile in Acciaio Inox AISI 304 - DN13 1/2" F - 3/4" F
Stainless Steel Flexible hose AISI 304 - DN13 1/2" F - 3/4" F

cm	20	25	30	35	40	45	50	60	80	100
----	----	----	----	----	----	----	----	----	----	-----



11612M34F

Flessibile in Acciaio Inox AISI 304 - DN13 1/2" M - 3/4" F
Stainless Steel Flexible hose AISI 304 - DN13 1/2" M - 3/4" F

cm	20	25	30	35	40	45	50	60	80	100
----	----	----	----	----	----	----	----	----	----	-----



11634M12F

Flessibile in Acciaio Inox AISI 304 - DN13 3/4" M - 1/2" F
Stainless Steel Flexible hose AISI 304 - DN13 3/4" M - 1/2" F

cm	20	25	30	35	40	45	50	60	80	100
----	----	----	----	----	----	----	----	----	----	-----



116C12F12F

Flessibile in Acciaio Inox AISI 304 - DN13 1/2" F - 1/2" FC
Stainless Steel Flexible hose AISI 304 - DN13 1/2" F - 1/2" FC

cm	20	25	30	35	40	45	50	60	80	100
----	----	----	----	----	----	----	----	----	----	-----



116C12M12F

Flessibile in Acciaio Inox AISI 304 - DN13 1/2" M - 1/2" FC
Stainless Steel Flexible hose AISI 304 - DN13 1/2" M - 1/2" FC

cm	20	25	30	35	40	45	50	60	80	100
----	----	----	----	----	----	----	----	----	----	-----



116C34F34F

Flessibile in Acciaio Inox AISI 304 - DN13 3/4" F - 3/4" FC
Stainless Steel Flexible hose AISI 304 - DN13 3/4" F - 3/4" FC

cm	20	25	30	35	40	45	50	60	80	100
----	----	----	----	----	----	----	----	----	----	-----



116C34M34F

Flessibile in Acciaio Inox AISI 304 - DN13 3/4" M - 3/4" FC
Stainless Steel Flexible hose AISI 304 - DN13 3/4" M - 3/4" FC

cm	20	25	30	35	40	45	50	60	80	100
----	----	----	----	----	----	----	----	----	----	-----



116C12F34F

Flessibile in Acciaio Inox AISI 304 - DN13 1/2" F - 3/4" FC
Stainless Steel Flexible hose AISI 304 - DN13 1/2" F - 3/4" FC

cm	20	25	30	35	40	45	50	60	80	100
----	----	----	----	----	----	----	----	----	----	-----



116C12M34F

Flessibile in Acciaio Inox AISI 304 - DN13 1/2" M - 3/4" FC
Stainless Steel Flexible hose AISI 304 - DN13 1/2" M - 3/4" FC

cm	20	25	30	35	40	45	50	60	80	100
----	----	----	----	----	----	----	----	----	----	-----



116C34F12F

Flessibile in Acciaio Inox AISI 304 - DN13 3/4" F - 1/2" FC
Stainless Steel Flexible hose AISI 304 - DN13 3/4" F - 1/2" FC

cm	20	25	30	35	40	45	50	60	80	100
----	----	----	----	----	----	----	----	----	----	-----

RUBINETTERIA
TAPS

FLESSIBILI
FLEXIBLE HOSES

MINUTERIA
MINUTERY

VALVOLE
VALVES

RACCORDERIA
FITTINGS

ACCESSORI
ACCESSORIES

COMPONENTI PLASTICI
PLASTIC COMPONENTS

FLESSIBILI ANTIVIBRANTI

IN ACCIAIO ZINCATO

ANTI-VIBRATION FLEXIBLES

IN GALVANIZED STEEL



DATI TECNICI - TECHNICAL DATA:

Flessibili antivibranti made in Italy rivestiti con treccia in Acciaio Zincato ed interno in tubo in gomma alimentare EPDM utilizzati per il collegamento tra la rete idrica e pompe, caldaie, autoclavi e depuratori, sono disponibili nelle misure da 1/2" fino a 2". Tutti i flessibili sono raccordati con macchine automatiche ed il risultato è l'assoluta precisione di ogni pezzo prodotto per una garanzia di totale qualità.

Made in Italy anti-vibration flexible hoses, galvanized steel braided, with internal in non-toxic EPDM rubber, used for the connection between the water mains and pumps, boilers, autoclaves and water conditioner; available from 1/2" to 2" size. All the hoses are connected with automatic machines and the result is the absolute precision of each produced piece for a total quality guarantee.

APPLICAZIONI - APPLICATIONS



MATERIALI - MATERIALS

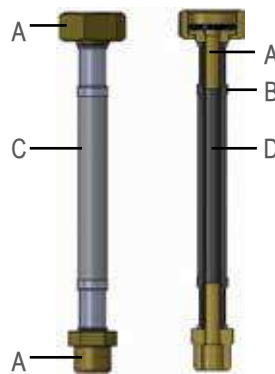

RACCORDI - FITTINGS:

A) Ottone CW614N e CW617N giallo o nichelato
Brass CW614N and CW617N yellow or nickel plated





BUSSOLE - SLEEVES:

B) Alluminio 99,5%
Aluminium 99,5%

TUBO - HOSE:

C) Treccia in Acciaio Zincato
wires braid n stainless steel galvanized
D) Tubo interno: gomma EPDM atossico
Internal pipe EPDM rubber, atoxic

CRATTERISTICHE - FEATURES

	DN 13 - 1/2"	DN 19 - 3/4"	DN 25 - 1"	DN 32 1" 1/4	DN 40 - 1" 1/2	DN 50 2"
	PRESSIONE D'ESERCIZIO - WORKING PRESSURE:					
	10 BAR	10 BAR	10 BAR	6 BAR	6 BAR	4 BAR
	PORTATA A 3 BAR - FLOW RATE AT 3 BAR:					
	120 lit/min	120 lit/min	200 lit/min	400 lit/min	700 lit/min	1.050 lit/min
	TEMPERATURA D'IMPIEGO - WORKING TEMPERATURE:					
	-10°C +90°C	-10°C +90°C	-10°C +90°C	-10°C +90°C	-10°C +90°C	-10°C +90°C
	FORO MINIMO PASSAGGIO D'ACQUA - FITTING INNER DIAMETER:					
	9,3 mm	15 mm	20 mm	26 mm	32 mm	41 mm
	RAGGIO CURVATURA MINIMO - MINIMUM BENDING RADIUS:					
	45 mm	70 mm	100 mm	190 mm	230 mm	300 mm
	Ø INTERNO - INNER Ø:					
	Ø 13 mm	Ø 19 mm	Ø 25 mm	Ø 30 mm	Ø 40 mm	Ø 50 mm
	Ø ESTERNO - OUTER Ø:					
	Ø 19 mm	Ø 27 mm	Ø 33 mm	Ø 42 mm	Ø 52 mm	Ø 62 mm

FLESSIBILE IN ACCIAIO ZINCATO E RACCORDI IN OTTONE GIALLO



Flessibile in Acciaio zincato e raccordo in ottone giallo.
Galvanized Steel Flexible hose and yellow brass fittings.

ART.	TUBO - HOSE					RACCORDI - FITTINGS				
	cm	20	30	40	50	60	70	80	90	100
44212					DN13					1/2" M - 1/2" F
44234					DN19					3/4" M - 3/4" F
44210					DN25					1" M - 1" F
442114					DN32					1 1/4" M - 1 1/4" F
442112					DN40					1 1/2" M - 1 1/2" F
44220					DN50					2" M - 2" F

GALVANIZED STEEL FLEXIBLE HOSE AND YELLOW BRASS FITTINGS



Flessibile in Acciaio zincato e raccordo in ottone giallo.
Galvanized Steel Flexible hose and yellow brass fittings.

ART.	TUBO - HOSE					RACCORDI - FITTINGS				
	cm	20	30	40	50	60	70	80	90	100
442FF12					DN13					1/2" F - 1/2" F
442FF34					DN19					3/4" F - 3/4" F
442FF10					DN25					1" F - 1" F
442FF114					DN32					1 1/4" F - 1 1/4" F
442FF112					DN40					1 1/2" F - 1 1/2" F
442FF20					DN50					2" F - 2" F



Flessibile in Acciaio zincato e raccordo in ottone giallo.
Galvanized Steel Flexible hose and yellow brass fittings.

ART.	TUBO - HOSE					RACCORDI - FITTINGS				
	cm	20	30	40	50	60	70	80	90	100
442C12					DN13					1/2" M - 1/2" FC
442C34					DN19					3/4" M - 3/4" FC
442C10					DN25					1" M - 1" FC



Flessibile in Acciaio zincato e raccordo in ottone giallo.
Galvanized Steel Flexible hose and yellow brass fittings.

ART.	TUBO - HOSE					RACCORDI - FITTINGS				
	cm	20	30	40	50	60	70	80	90	100
442FC12					DN13					1/2" F - 1/2" FC
442FC34					DN19					3/4" F - 3/4" FC
442FC10					DN25					1" F - 1" FC

FLESSIBILE IN ACCIAIO ZINCATO E RACCORDI IN OTTONE NICHELATO



Flessibile in Acciaio zincato e raccordo in ottone nichelato.
Galvanized Steel Flexible hose and nickel plated brass fittings.

ART.	TUBO - HOSE					RACCORDI - FITTINGS				
	cm	20	30	40	50	60	70	80	90	100
44112					DN13					1/2" M - 1/2" F
44134					DN19					3/4" M - 3/4" F
44110					DN25					1" M - 1" F
441114					DN32					1 1/4" M - 1 1/4" F
441112					DN40					1 1/2" M - 1 1/2" F
44120					DN50					2" M - 2" F

GALVANIZED STEEL FLEXIBLE HOSE AND NICKEL-PLATED BRASS FITTINGS



Flessibile in Acciaio zincato e raccordo in ottone nichelato.
Galvanized Steel Flexible hose and nickel plated brass fittings.

ART.	TUBO - HOSE					RACCORDI - FITTINGS				
	cm	20	30	40	50	60	70	80	90	100
441FF12					DN13					1/2" F - 1/2" F
441FF34					DN19					3/4" F - 3/4" F
441FF10					DN25					1" F - 1" F
441FF114					DN32					1 1/4" F - 1 1/4" F
441FF112					DN40					1 1/2" F - 1 1/2" F
441FF20					DN50					2" F - 2" F



Flessibile in Acciaio zincato e raccordo in ottone nichelato.
Galvanized Steel Flexible hose and nickel plated brass fittings.

ART.	TUBO - HOSE					RACCORDI - FITTINGS				
	cm	20	30	40	50	60	70	80	90	100
441C12					DN13					1/2" M - 1/2" FC
441C34					DN19					3/4" M - 3/4" FC
441C10					DN25					1" M - 1" FC



Flessibile in Acciaio zincato e raccordo in ottone nichelato.
Galvanized Steel Flexible hose and nickel plated brass fittings.

ART.	TUBO - HOSE					RACCORDI - FITTINGS				
	cm	20	30	40	50	60	70	80	90	100
441FC12					DN13					1/2" F - 1/2" FC
441FC34					DN19					3/4" F - 3/4" FC
441FC10					DN25					1" F - 1" FC

RUBINETTERIA
TAPS

FLESSIBILI
FLEXIBLE HOSES

MINUTERIA
MINUTERY

VALVOLE
VALVES

RACCORDERIA
FITTINGS

ACCESSORI
ACCESSORIES

COMPONENTI PLASTICI
PLASTIC COMPONENTS

FLESSIBILI ANTIVIBRANTI INOX

TRECCIA IN ACCIAIO INOX PER POMPE E AUTOCLAVI

STAINLESS STEEL ANTI-VIBRATION FLEXIBLES

STAINLESS STEEL BRAIDED FOR PUMPS AND AUTOCLAVES



DATI TECNICI - TECHNICAL DATA:

Flessibili antivibranti made in Italy rivestiti con treccia in Acciaio Inox AISI 304 ed interno in tubo in gomma alimentare EPDM utilizzati per il collegamento tra la rete idrica e pompe, caldaie, autoclavi e depuratori, sono disponibili nelle misure da 1/2" fino a 2". Tutti i flessibili sono raccordati con macchine automatiche ed il risultato è l'assoluta precisione di ogni pezzo prodotto per una garanzia di totale qualità.

Made in Italy anti-vibration flexible hoses, AISI 304 stainless steel braided, with internal in non-toxic EPDM rubber, used for the connection between the water mains and pumps, boilers, autoclaves and water conditioner; available from 1/2" to 2" size. All the hoses are connected with automatic machines and the result is the absolute precision of each produced piece for a total quality guarantee.

APPLICAZIONI - APPLICATIONS



MATERIALI - MATERIALS

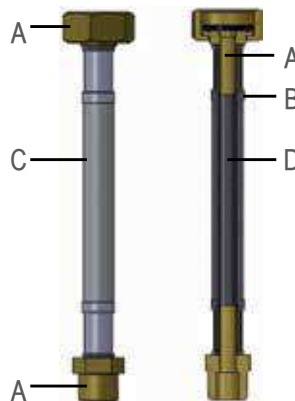

RACCORDI - FITTINGS:

A) Ottone CW614N e CW617N giallo o nichelato
Brass CW614N and CW617N yellow or nickel plated







BUSSOLE - SLEEVES:

B) Alluminio 99,5%
Aluminium 99,5%

TUBO - HOSE:

C) Treccia in Acciaio AISI 304
Braid in Steel AISI 304
D) Tubo interno: gomma EPDM atossico
Internal pipe EPDM rubber, atoxic

GRATTERISTICHE - FEATURES

	DN 13 - 1/2"	DN 19 - 3/4"	DN 25 - 1"	DN 32 1" 1/4	DN 40 - 1" 1/2	DN 50 2"
	PRESSIONE D'ESERCIZIO - WORKING PRESSURE:					
	15 BAR	15 BAR	15 BAR	9 BAR	6 BAR	7 BAR
	PORTATA A 3 BAR - FLOW RATE AT 3 BAR:					
	65 lit/min	120 lit/min	200 lit/min	400 lit/min	700 lit/min	1.050 lit/min
	TEMPERATURA D'IMPIEGO - WORKING TEMPERATURE:					
	-10°C +90°C	-10°C +90°C	-10°C +90°C	-10°C +90°C	-10°C +90°C	-10°C +90°C
	FORO MINIMO PASSAGGIO D'ACQUA - FITTING INNER DIAMETER:					
	9,3 mm	15 mm	20 mm	25 mm	32 mm	40 mm
	RAGGIO CURVATURA MINIMO - MINIMUM BENDING RADIUS:					
	45 mm	70 mm	100 mm	190 mm	230 mm	300 mm
	Ø INTERNO - INNER Ø:					
	Ø 13 mm	Ø 19 mm	Ø 25 mm	Ø 30 mm	Ø 40 mm	Ø 50 mm
	Ø ESTERNO - OUTER Ø:					
	Ø 19 mm	Ø 27 mm	Ø 33 mm	Ø 42 mm	Ø 52 mm	Ø 62 mm

**FLESSIBILE IN ACCIAIO INOX AISI 304
E RACCORDI IN OTTONE NICHELATO**



Flessibile in Acciaio INOX AISI 304 e raccordo in ottone nichelato.
Stainless Steel Flexible hose AISI 304 and nickel-plated brass fittings.

ART.	TUBO - HOSE					RACCORDI - FITTINGS				
	cm	20	30	40	50	60	70	80	90	100
44312					DN13					1/2" M - 1/2" F
44334					DN19					3/4" M - 3/4" F
44310					DN25					1" M - 1" F

**STAINLESS STEEL FLEXIBLE HOSE AISI 304
AND NICKEL-PLATED BRASS FITTINGS**



Flessibile in Acciaio INOX AISI 304 e raccordo in ottone nichelato.
Stainless Steel Flexible hose AISI 304 and nickel-plated brass fittings.

ART.	TUBO - HOSE					RACCORDI - FITTINGS				
	cm	20	30	40	50	60	70	80	90	100
443FF12					DN13					1/2" F - 1/2" F
443FF34					DN19					3/4" F - 3/4" F
443FF10					DN25					1" F - 1" F



Flessibile in Acciaio INOX AISI 304 e raccordo in ottone nichelato.
Stainless Steel Flexible hose AISI 304 and nickel-plated brass fittings.

ART.	TUBO - HOSE					RACCORDI - FITTINGS				
	cm	20	30	40	50	60	70	80	90	100
443C12					DN13					1/2" M - 1/2" FC
443C34					DN19					3/4" M - 3/4" FC
443C10					DN25					1" M - 1" FC



Flessibile in Acciaio INOX AISI 304 e raccordo in ottone nichelato.
Stainless Steel Flexible hose AISI 304 and nickel-plated brass fittings.

ART.	TUBO - HOSE					RACCORDI - FITTINGS				
	cm	20	30	40	50	60	70	80	90	100
443FC12					DN13					1/2" F - 1/2" FC
443FC34					DN19					3/4" F - 3/4" FC
443FC10					DN25					1" F - 1" FC

**FLESSIBILE IN ACCIAIO INOX AISI 304
E RACCORDI IN OTTONE GIALLO**



Flessibile in Acciaio INOX AISI 304 e raccordo in ottone giallo.
Stainless Steel Flexible hose AISI 304 and yellow brass fittings.

ART.	TUBO - HOSE					RACCORDI - FITTINGS				
	cm	20	30	40	50	60	70	80	90	100
44412					DN13					1/2" M - 1/2" F
44434					DN19					3/4" M - 3/4" F
44410					DN25					1" M - 1" F

**STAINLESS STEEL FLEXIBLE HOSE AISI 304
AND YELLOW BRASS FITTINGS**



Flessibile in Acciaio INOX AISI 304 e raccordo in ottone giallo.
Stainless Steel Flexible hose AISI 304 and yellow brass fittings.

ART.	TUBO - HOSE					RACCORDI - FITTINGS				
	cm	20	30	40	50	60	70	80	90	100
444FF12					DN13					1/2" F - 1/2" F
444FF34					DN19					3/4" F - 3/4" F
444FF10					DN25					1" F - 1" F



Flessibile in Acciaio INOX AISI 304 e raccordo in ottone giallo.
Stainless Steel Flexible hose AISI 304 and yellow brass fittings.

ART.	TUBO - HOSE					RACCORDI - FITTINGS				
	cm	20	30	40	50	60	70	80	90	100
444C12					DN13					1/2" M - 1/2" FC
444C34					DN19					3/4" M - 3/4" FC
444C10					DN25					1" M - 1" FC



Flessibile in Acciaio INOX AISI 304 e raccordo in ottone giallo.
Stainless Steel Flexible hose AISI 304 and yellow brass fittings.

ART.	TUBO - HOSE					RACCORDI - FITTINGS				
	cm	20	30	40	50	60	70	80	90	100
444FC12					DN13					1/2" F - 1/2" FC
444FC34					DN19					3/4" F - 3/4" FC
444FC10					DN25					1" F - 1" FC

RUBINETTERIA
TAPS

FLESSIBILI
FLEXIBLE HOSES

MINUTERIA
MINUTERY

VALVOLE
VALVES

RACCORDERIA
FITTINGS

ACCESSORI
ACCESSORIES

COMPONENTI PLASTICI
PLASTIC COMPONENTS

TUBI DI RAME - COPPER TUBES



Tubo in rame ricotto cromato in barre da 5 metri Ø10 mm.
Pipe in soft copper chrome plated in roll of 5 meters, Ø10 mm.

11110ROT5



Tubo in rame ricotto cromato in barre da 5 metri Ø12 mm.
Pipe in soft copper chrome plated in roll of 5 meters, Ø12 mm.

11112ROT5



Tubo in rame ricotto cromato in barre da 5 metri Ø14 mm.
Pipe in soft copper chrome plated in roll of 5 meters, Ø14 mm.

11114ROT5



Tubo in rame ricotto cromato in barre da 1,5 metro Ø10 mm.
Pipe in soft copper chrome plated in roll of 1,5 meter, Ø10 mm.

11110150



Tubo liscio in rame cromato Ø10 mm con attacco filettato 10M x 1.
C.p. copper pipe Ø10 mm threaded 10M x 1.

	cm
114M1035	35
114M1045	45
114M1050	50
114M1060	60



Tubo liscio in rame cromato Ø10 mm con cartella e dado.
C.p. copper pipe Ø10 mm with nut.

	cm	
1141230	30	1/2
1141235	35	1/2
1141240	40	1/2
1141250	50	1/2
1143830	30	3/8
1143835	35	3/8
1143840	40	3/8
1143850	50	3/8



Tubo in rame ricotto cromato in barre da 1 metro Ø10 mm.
Pipe in soft copper chrome plated in roll of 1 meter, Ø10 mm.

11110100



Tubo liscio in rame cromato Ø10 mm con attacco dado e bicono Ø10 mm. cm 35.
C.p. copper pipe Ø10 mm with nut and 3 pcs washers Ø10 mm. cm 35.

114F1035

ADATTATORI PER FLESSIBILI - FLEXIBLE HOSES ADAPTER



Adattatore per flessibili e miscelatori, attacco femmina filetto F10x1, in ottone cromato.
Flexible hoses and mixers adapter, female connection F10x1, in chrome-plated brass.

Art.	Attacco Maschio Male Connection	Attacco Femmina Female Connection	Prezzo
108RDM8	M 8 x1	F 10x1	
108RDM9	M 9 x1	F 10x1	
108RDM11	M 11x1	F 10x1	
108RDM12	M 12 x1	F 10x1	

RACCORDI E NIPPLES - CONNECTIONS AND NIPPLES



Nipples con guarnizione in gomma, ranella ed anello tagliato in ottone. 1/2 x 10 oppure 3/8x10.
Nipples with nut and 3 pcs washers. 1/2 x 10 or 3/8x10.

1253810 3/8 x 10
1251210 1/2 x 10



Nipples prolungato con guarnizione in gomma, ranella ed anello tagliato in ottone. 1/2 x 3/8 oppure 1/2 x 10.
Extended c.p. nipples with nut and 3 pcs washers. 1/2 x 3/8 or 1/2 x 10.

125L1238 1/2 x 3/8
125L1210 1/2 x 10



Doppio nipple con guarnizioni in 3 pezzi. 3/8 x 10 x 10.
C.p. double nipple with nut and 3 pcs washers. 3/8 x 10 x 10.

125D



Raccordo femmina completo con guarnizioni in 3 pezzi, 1/2 x 10 oppure 3/8x10.
C.p. female connection with nut and 3 pcs washers, 1/2 x 10 or 3/8x10.

125F3810 3/8 x 10
125F 1/2 x 10



Raccordo a gomito con guarnizione in gomma, ranella e anello tagliato in ottone. 1/2 x 10 mm.
Connecting elbow with nut and 3 pcs washers. 1/2 x 10 mm.

126M1210



Raccordo a gomito con guarnizioni in gomma, ranelle e anelli tagliati in ottone. 10 x 10 mm.
Connecting elbow with 2 nuts and 3 pcs washers. 10 x 10 mm.

1261010



Raccordo a T con guarnizioni in gomma, ranelle e anelli tagliati in ottone. 10 x 10 x 10 mm.
Equal T connection with 3 nuts and 3 pcs washers. 10 x 10 x 10 mm.

126T101010

RUBINETTERIA
TAPS

FLESSIBILI
FLEXIBLE HOSES

MINUTERIA
MINUTERY

VALVOLE
VALVES

RACCORDERIA
FITTINGS

ACCESSORI
ACCESSORIES

COMPONENTI PLASTICI
PLASTIC COMPONENTS



RR[®]
REMER RUBINETTERIE

**MINUTERIA
MINUTERY**

MINUTERIA - MINUTERY

RUBINETTERIA
TAPS

FLESSIBILI
FLEXIBLE HOSES

MINUTERIA
MINUTERY

VALVOLE
VALVES

RACCORDERIA
FITTINGS

ACCESSORI
ACCESSORIES

COMPONENTI PLASTICI
PLASTIC COMPONENTS

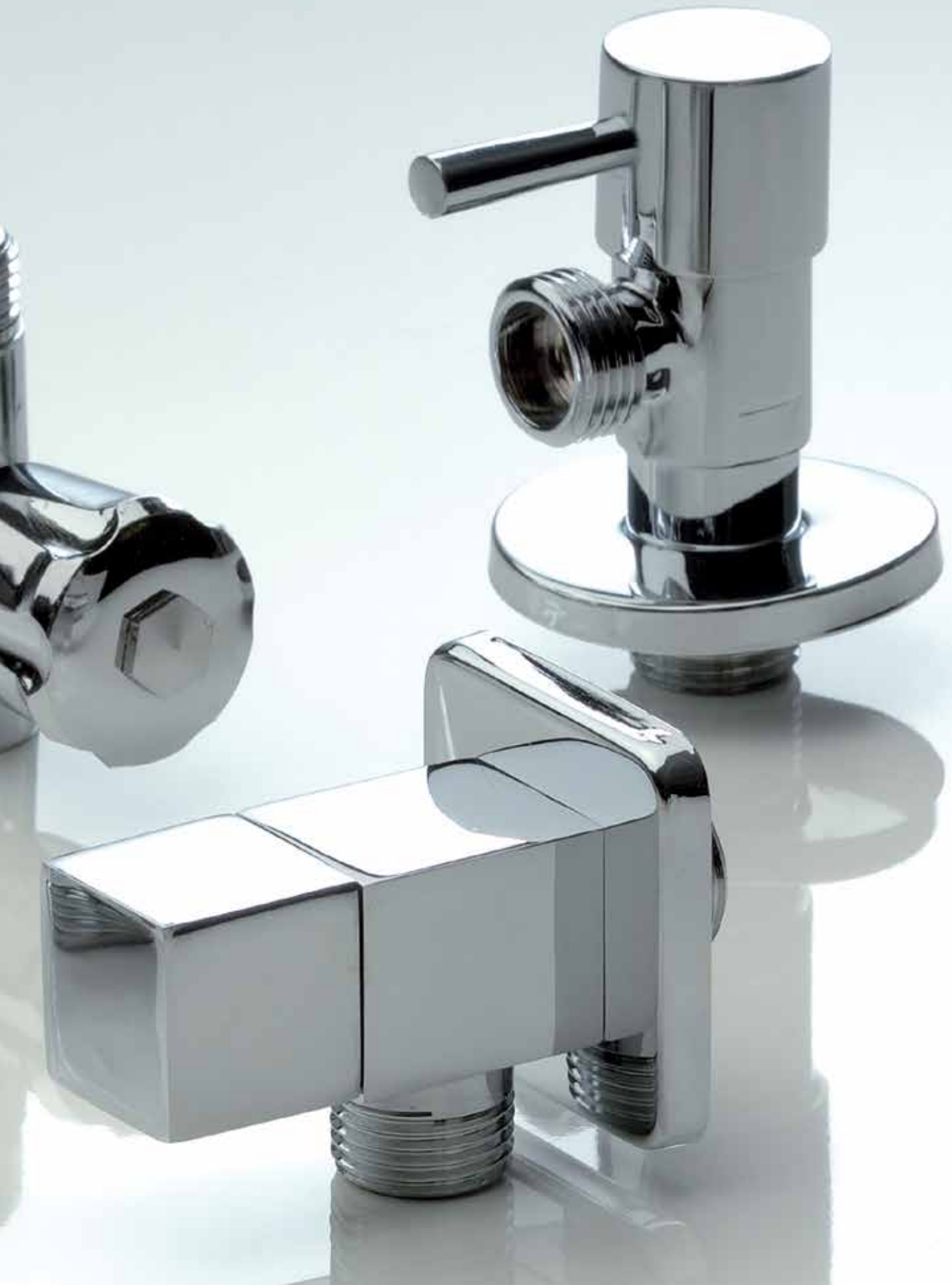

RUBINETTI SOTTOLAVABO - C.P. BRASS ANGLE VALVE



Raccordo 3/8x10 con guarnizioni in 3 pezzi.
C.P. nut with 3 pcs washers 3/8x10.

117RA



Raccordo 1/2x10 con guarnizioni in 3 pezzi.
C.P. nut with 3 pcs washers 1/2x10.

117RA1210



Rubinetto sottolavabo con rosetta, 1/2x3/8.
C.P. brass angle valve with flange, 1/2x3/8.

1171238

Rubinetto sottolavabo con rosetta, 1/2x1/2.
C.P. brass angle valve with flange, 1/2x1/2.

1171212



Rubinetto sottolavabo con calotta e rosetta, 1/2x10.
C.P. brass angle valve with flange, 1/2x10.

1171210



Curvetta sottolavabo, 1/2x10, con rosetta in ottone cromato.
C.P. brass elbow connection for wash basin, with flange, 1/2x10.

1241210



Rubinetto sottolavabo a vitone, con filtro e snodo, 1/2x10, con rosetta in ottone cromato.
C.P. brass angle valve with filter, balljoint and c.p. brass flange, 1/2x10.

120SN1210



Rubinetto combinato 1/2" sottolavabo e 3/4" attacco lavatrice, 1/2 x 3/4 x 10.
C.P. brass union valve 1/2", with undersink coupling and 3/4" connection for washing machine, 1/2 x 3/4 x 10

121T



Rubinetto sottolavabo con filtro e calotta, 1/2x10, con rosetta in ottone cromato.
C.P. brass angle valve with filter and flange, 1/2x10.

1231210



Rubinetto a sfera con guarnizione in PTFE, con calotta e rosetta in ottone cromato, 1/2x10.
C.P. brass ball valve with PTFE washer and flange, 1/2x10.

128R1210

1/2 x 10



Rubinetto sottolavabo con filtro e snodo, 1/2x10, con rosetta in ottone cromato.
C.P. brass angle valve with filter, ball joint and flange, 1/2x10.

123SN1210



Rubinetto sottolavabo con filtro e snodo, 1/2x10, con rosetta in ottone cromato.
C.P. brass angle valve with filter, ball joint and flange, 1/2x10.

127ASN1210



Rubinetto sottolavabo con filtro, calotta, 1/2x10 e rosetta in ottone cromato.
C.P. brass angle valve with filter and flange, 1/2x10.

127A1210



Rubinetto sottolavabo "MINIMAL", con vitone ceramico, con maniglia a leva, 1/2x3/8.
C.P. brass "MINIMAL" angle valve, with ceramic headvalve, with lever handle, 1/2x3/8.

128L1238

Rubinetto sottolavabo "MINIMAL", con vitone ceramico, con maniglia a leva, dado e guarnizione art. 117 RA, 1/2x10.
C.P. brass "MINIMAL" angle valve, with ceramic headvalve, with lever handle, nut and washers art. 117 RA, 1/2x10.

128L1210

Rubinetto sottolavabo "MINIMAL", con vitone ceramico, con maniglia a leva, 1/2x1/2.
C.P. brass "MINIMAL" angle valve, with ceramic headvalve, with lever handle, 1/2x1/2.

128L1212



Rubinetto sottolavabo quadrato, con vitone ceramico, 1/2x3/8.
C.P. brass squared angle valve, with ceramic head valve, 1/2x3/8.

128S1238

Rubinetto sottolavabo quadrato, con dado e guarnizione art. 117 RA, con vitone ceramico, 1/2x10.
C.P. brass squared angle valve, with nut and washers art. 117 RA, with ceramic head valve, 1/2x10.

128S1210

Rubinetto sottolavabo quadrato, con vitone ceramico, 1/2x1/2.
C.P. brass squared angle valve, with ceramic head valve, 1/2x1/2.

128S1212



Rubinetto sottolavabo "Esagonale", con vitone ceramico, 1/2x3/8.
C.P. brass "Hexagonal" angle valve, with ceramic head valve, 1/2x3/8.

128E1238

Rubinetto sottolavabo "Esagonale", con dado e guarnizione art. 117 RA, con vitone ceramico, 1/2x10.
C.P. brass "Hexagonal" angle valve, with nut and washers art. 117 RA, with ceramic head valve, 1/2x10.

128E1210

Rubinetto sottolavabo "Esagonale", con vitone ceramico, 1/2x1/2.
C.P. brass "Hexagonal" angle valve, with ceramic head valve, 1/2x1/2.

128E1212



Rubinetto sottolavabo con filtro, 1/2x1/2, 1/2x3/8, con rosetta in ottone cromato.
C.P. brass angle valve with filter and flange, 1/2x1/2, 1/2x3/8.

127A1212 1/2" x 1/2"

127A1238 1/2" x 3/8"



Rubinetto sottolavabo 1/2x1/2 con rosetta.
C.P. brass angle valve for wash basin 1/2x1/2 with flange.

1291212

Rubinetto sottolavabo 1/2x3/8 con rosetta.
C.P. brass angle valve for wash basin 1/2x3/8 with flange.

1291238



Rubinetto sottolavabo con filtro, 1/2x1/2, con rosetta in ottone cromato.
C.P. brass angle valve with filter and flange, 1/2x1/2.

1231212

Rubinetto sottolavabo con filtro, 1/2x3/8, con rosetta in ottone cromato.
C.P. brass angle valve with filter and flange, 1/2x3/8.

1231238



Rubinetto a sfera con guarnizione in PTFE e rosetta, 1/2x1/2 oppure 1/2x3/8.
C.P. brass ball valve with PTFE washer and flange, 1/2x1/2 or 1/2x3/8.

128R1212 1/2" x 1/2"

128R1238 1/2" x 3/8"

RUBINETTERIA
TAPS

FLESSIBILI
FLEXIBLE HOSES

MINUTERIA
MINUTERY

VALVOLE
VALVES

RACCORDERIA
FITTINGS

ACCESSORI
ACCESSORIES

COMPONENTI PLASTICI
PLASTIC COMPONENTS

ROSETTE - WALL FLANGES



Rosetta pesante in ottone cromato, 1/2.
Heavy wall flange in chrome plated brass 1/2.

1300C12

Rosetta pesante in acciaio inox, 1/2.
Heavy wall flange in stainless steel, 1/2.

130AC12

Rosetta pesante in acciaio inox, Ø esterno 80 mm, 1/2.
1/2x80.
Heavy wall flange in stainless steel, external Ø 80 mm, 1/2. 1/2x80.

1300C1280 1/2x80



Rosetta con foro esagonale in acciaio inox, 1/2.
Stainless steel wall flange with hexagonal hole, 1/2.

13612



Rosetta con alette pesante in ottone cromato Ø mm 57, 1/2.
Heavy wall flange in chrome plated brass Ø 57 mm, 1/2.

1310C12



Rosetta pesante quadrata in ottone cromato, 1/2".
Heavy squared wall flange in c.p. brass, 1/2".

130S12



Rosetta con alette pesante in acciaio INOX Ø mm 57, 1/2 e 3/4.
Heavy wall flange in stainless steel Ø 57 mm, 1/2 and 3/4.

131AC12 1/2

131AC34 3/4



Rosetta apribile in ottone cromato.
Openable wall flange in c.p. brass.
Ø 14, 3/8, 1/2, 3/4, 1".

13238 3/8

13212 1/2

13234 3/4

13210 1"



Rosetta pesante in ottone cromato, per serie minimali, 1/2.
Heavy wall flange in chrome plated brass, for minimal series, 1/2.

130N12



Cappuccio a 2 pezzi universale, per rubinetti incasso, cromato, in ottone.
Universal cap in 2 pieces, for built-in taps, chrome plated, in brass.

138



Tappo con rosone e vite, 1/2.
Plug with wall flange and screw, 1/2.

14212



Rosone a muro con OR, in ottone cromato, per serie minimali, Ø 32.
Wall flange without OR in c.p. brass, for minimal series, Ø 32.

14432



Rosone a muro quadrato con OR, in ottone cromato, per serie quadrate e sifoni, Ø 32.
Wall flange with OR, in c.p. brass, for squared series and traps, Ø 32.

144S32



Rosone a muro in ottone cromato, Ø foro mm 26, 30, 32.
Standard wall flange in c.p. brass, Ø hole mm 26, 30, 32.

14526

14530

14532



Rosone a muro in ottone cromato, Ø est mm.77, Ø foro mm 26, 30, 32, 40.
Wall flange for traps in c.p. brass, ext. Ø 77 mm, hole Ø mm 26, 30, 32, 40.

14626

14630

14632

14640



Rosone a muro gigante in ottone cromato, Ø esterno mm 105, Ø foro mm 26, 30, 32.
Giant wall flange in c.p. brass, external Ø mm 105, hole Ø mm 26, 30, 32.

14726

14730

14732



Dado in ottone cromato, 1" con foro Ø mm 26, 1 1/4 Ø 32.
C.P. round nut, 1" hole Ø 26, 1 1/4 hole Ø 32.

14926 Ø 26

14932 Ø 32



Rosone Ø mm 77, foro ovale, in ottone cromato.
C.p. brass flange Ø mm 77, with oval hole.

1400C

CANOTTI, RACCORDI E TUBI - TUBES AND CONNECTORS



Canotto in ottone cromato Ø 26, 30, 32, lunghezza cm 30, 100.
C.P. brass tube, plain end, Ø 26, 30, 32, length 30, 100 cm.

1502630	Ø26x30	1503030	Ø30x30
1503230	Ø32x30	15032100	Ø32x100



Canotto pesante in ottone cromato con spessore 0,6 mm, Ø 32, lunghezza cm 30.
C.P. heavy brass tube, thickness mm 0,6, plain end, Ø 32, length cm 30.

150P3230	Ø32x30
-----------------	--------



Canotto in ottone cromato con cartella Ø 26, 30, 32 lunghezza cm 30 e Ø 32 lunghezza cm 15, 20, 25.
C.P. brass tube with bordered end Ø 26, 30, 32, length 30 cm and Ø 32 length cm 15, 20, 25.

1522630	Ø26x30	1523030	Ø30x30
1523215	Ø32x15	1523225	Ø32x25
1523220	Ø32x20	1523230	Ø32x30



Canotto pesante in ottone cromato con spessore 0,6 mm, con cartella, Ø 32, lunghezza cm 30.
C.P. heavy brass tube, thickness mm 0,6, with bordered end, Ø 32, length cm 30.

152P3230	Ø32x30
-----------------	--------



Canotto telescopico con guarnizione OR, Ø 32 lunghezza cm 13.
Telescopic tube with OR washer, Ø 32 length 13 cm.

15332	Ø32x13
--------------	--------



Raccordo di congiunzione universale, in ottone cromato, Ø 26, 30, 32, 40, con 2 guarnizioni OR.
C.P. brass universal connector, Ø mm 26, 30, 32, 40 with 2 OR washers.

15426	Ø26
15430	Ø30
15432	Ø32
15440	Ø40



Raccordo di congiunzione universale ridotto, in ottone cromato, Ø 26x32, 32x40, con 2 guarnizioni OR.
C.P. brass universal reduced connector, Ø mm 26x32, 32x40, with 2 OR washers.

154R2632	Ø26x32
154R3240	Ø32x40



Canotto flessibile in rame cromato, Ø 32, lunghezza cm 30.
Flexible tube in chrome plated copper, Ø 32, length 30 cm.

1553230	Ø32x30
----------------	--------



Canotto eccentrico in ottone cromato, Ø 30, lunghezza cm 30.
Eccentric C.P. brass tube, Ø 30, length 30 cm.

1583030	Ø30x30
----------------	--------



Tubo a 90° per scarico cassetta in ottone cromato Ø cm 30, cm 15x25.
90° Tube for water tank for W.C. in C.P. brass Ø 30 cm, 15x25 cm.

165	
------------	--



Tubo a 45° per scarico cassetta in ottone cromato Ø cm 30.
45° Tube for water tank for W.C. in C.P. brass Ø 30 cm.

166	
------------	--



Canotto con dado e cartella in ottone cromato con attacco per scarico lavatrice/lavastoviglie, 1"1/4.
C.P. brass pipe with nut and bordered end, plus side connection for washing machine or dishwasher outlet tube, 1"1/4.

168	
------------	--



Tubo a "L" per flussometro esterno, in ottone cromato, Ø 25, 30.
"L" c.p. brass pipe, for wall mounted tap for wc, Ø 25, 30.

170TU25	Ø 25
----------------	------

170TU30	Ø 30
----------------	------

RUBINETTERIA
TAPS

FLESSIBILI
FLEXIBLE HOSES

MINUTERIA
MINUTERY

VALVOLE
VALVES

RACCORDERIA
FITTINGS

ACCESSORI
ACCESSORIES

COMPONENTI PLASTICI
PLASTIC COMPONENTS

PASSO RAPIDO - FLUSHING VALVES



Passo rapido esterno, 3/4.
External flushing valve, 3/4.

17034 3/4



Passo rapido a incasso con ritorno automatico, 3/4, 1".
Built-in flushing valve, with automatic return, 3/4, 1".

171RA34 3/4

171RA10 1"



Passo rapido a incasso con sfiatatoio, 3/4, 1".
Built-in flushing valve, 3/4, 1".

17134 3/4

17110 1"

GALLEGGIANTI - FLUSHING VALVES



Galleggiante "RR" silenzioso, 3/8, 1/2.
"RR" noiseless float valve, 3/8, 1/2.

17638 3/8

17612 1/2



Galleggiante tipo inglese, con tubetto, per forti erogazioni, 1/2, 3/4, 1".
Float valve, english type, with brass pipe, for high pressure, 1/2, 3/4, 1".

17512 1/2

17534 3/4

17510 1"



Galleggiante con asta in ottone regolabile, 3/4, 1", 1"1/4, 1"1/2, 2".
Float valve with adjustable brass rod, 3/4, 1", 1"1/4, 1"1/2, 2".

17834 3/4

17810 1"

178114 1" 1/4

178112 1" 1/2

17820 2"



Sfera Ø 90 in plastica soffiata con nottolino in ottone.
Plastic ball Ø 90 blown for art. 176 and 179 with brass nut.

180



Sfera Ø 120 in plastica attacco universale: scorrevole, filetto 1/4, filetto 5/16.
Plastic ball Ø 120, universal type (1/4, 5/16, sliding) for art. 175 and 178.

182UNI120



Sfera in plastica con scorrevole, Ø 150, 180, 220.
Plastic ball, sliding, Ø 150, 180, 220.

182150 Ø 150

182180 Ø 180

182220 Ø 220



Sfera in rame tonda, Ø 85, 150 senza nottolino.
Copper ball for float valves, Ø 85, 150, without brass nut.

18585 Ø 85

185150 Ø 150

RUBINETTI - TAPS

RUBINETTERIA
TAPS

FLESSIBILI
FLEXIBLE HOSES

MINUTERIA
MINUTERY

VALVOLE
VALVES

RACCORDERIA
FITTINGS

ACCESSORI
ACCESSORIES

COMPONENTI PLASTICI
PLASTIC COMPONENTS



Rubinetto per cassetta cromato, con tubetto e rosone, 1/2.
C.P. tap for W.C. tank with copper pipe and flange, 1/2.

18812



Rubinetto per cassetta cromato, con tubetti e rosetta, 3/8MX3/8F, 1/2MX3/8F.
Chrome plated W.C. tank tap, with extension pipes and flange, 3/8MX3/8F, 1/2MX3/8F.

19038 3/8MX3/8F

19012 1/2MX3/8F



Rubinetto portagomma a sfera, maniglia a leva, pulito e cromato, 1/2.
C.P. brass polished ball bibcock, hose-end with lever handle, 1/2.

19712



Rubinetto portagomma a sfera, maniglia a farfalla, cromato, 1/2.
Brass ball bibcock, hose-end with T handle in nickel plated brass, 1/2.

19912



Rubinetto portagomma in ottone giallo, pesante, 1/2, 3/4.
Hose union bibcock in yellow brass, heavy duty, 1/2, 3/4.

20012 1/2

20034 3/4



Rubinetto portagomma cromato, 1/2, 3/4.
C.p. hose union bibcock, 1/2, 3/4.

200T12 1/2

200T34 3/4



Rubinetto curvo in ottone giallo pesante, 1/2.
Plain-end bibcock in yellow brass, heavy duty, 1/2.

20112



Rubinetto portagomma a sfera, maniglia a leva, cromato, 3/8, 1/2, 3/4, 1".
Brass ball bibcock, hose-end with lever handle in nickel plated brass, 3/8, 1/2, 3/4, 1".

19838 3/8

19812 1/2

19834 3/4

19810 1"



Rubinetto curvo da giardino in ottone giallo trattato, 1/2 a maniglia, con rosetta pesante, aeratore e riduzione 3/4 per portagomma.
Plain-end garden bibcock, heavy duty, in treated yellow brass, 1/2, traditional handle, with heavy flange, aerator and 3/4 reduction for hose connection.

202MA



Rubinetto curvo da giardino in ottone giallo trattato, 1/2 a leva, con rosetta pesante, aeratore e riduzione 3/4 per portagomma.
Plain-end garden bibcock, heavy duty, in treated yellow brass, 1/2, lever type, with heavy flange, aerator and 3/4 reduction for hose connection.

202LE



Raccordo portagomma in ottone giallo, per art. 200, 1/2, 3/4, 1" (misura del rubinetto).
Hose connection for taps in yellow brass, for art. 200, 1/2, 3/4, 1".

20912 1/2

20934 3/4



Raccordo portagomma in ottone cromato, per art. 198, 1/2, 3/4, 1" (misura del rubinetto).
C.P. hose connection for art. 198, (size of reference tap), 1/2, 3/4, 1".

21012 1/2

21034 3/4



Raccordo a Y in ottone giallo, 3/4Fx3/4Mx3/4M.
Y yellow brass connection, 3/4Fx3/4Mx3/4M.

209Y



Raccordo a Y in ottone cromato, 3/4Fx3/4Mx3/4M.
Y chrome brass connection, 3/4Fx3/4Mx3/4M.

209YCR



Vitone di ricambio per articolo 202MA.
Spare part headvalve for art 202MA.

202MAVI



Rubinetto a snodo con maniglia mini Y, 1/2.
C.P. brass sink tap, with swivel spout, with mini Y handle, 1/2.

22412



Rubinetto a due maniglie per attacco lavatrice, 1/2x3/4.
C.P. brass washing machine bibcock, heavy model, 1/2x3/4.

25012



Rubinetto a due maniglie per attacco lavatrice, 1/2x3/4x3/4.
C.P. brass washing machine bibcock, heavy model, 1/2x3/4x3/4.

2501234



Rubinetto curvo con maniglia mini Y, 1/2.
C.P. polished brass bibcock, with mini Y handle, 1/2.

57EX



Rubinetto a snodo con attacco lavatrice, con maniglia mini Y, 1/2.
C.P. brass washing machine bibcock, with swivel spout, with mini Y handle, 1/2.

25212



Distanziatore per gruppi, con rubinetto per lavatrice 3/4x3/4x3/4.
C.P. brass washing machine bibcock, with connection, 3/4x3/4x3/4.

258



Coppia distanziatori con foro 3/8 e senza, in ottone cromato 3/4x3/4.
Set two pieces 3/4 c.p. brass connections with hole and without hole for 3/8 washing machine bibcock.

257



Rubinetto a tre vie, sottolavabo, per attacco lavatrice, 1/2x3/4.
C.P. three ways washing machine bibcock, brass model, 1/2x3/4.

259



Rubinetto a sfera, a tre vie, sottolavabo, per attacco lavatrice, 1/2Mx1/2Fx3/4M.
C.P. brass three ways washing machine mini ballvalve, 1/2Mx1/2Fx3/4M.

260



Rubinetto a sfera, maniglia a farfalla, con rosetta in ottone cromato, 1/2x1/2.
Angle valve with c.p. brass flange, 1/2x1/2.

2611212



Rubinetto a sfera per lavatrice, maniglia a farfalla, con rosetta in ottone cromato, 1/2x3/4.
C.P. brass hose bibcock for washing machine, with flange in C.P. brass, 1/2x3/4.

26112 1/2x3/4

RUBINETTERIA
TAPS

FLESSIBILI
FLEXIBLE HOSES

MINUTERIA
MINUTERY



Rubinetto a sfera, con valvola di non ritorno, con rosetta ottone cromato, 1/2x3/4.
C.P. brass hose bibcock for washing machine, with flange in C.P. brass, 1/2x3/4, with no-return valve.

261NR12



Rubinetto a sfera per lavatrice, maniglia a leva, con rosetta in ottone cromato, 1/2x3/4.
C.P. brass hose bibcock for washing machine, with flange in C.P. brass, 1/2x3/4.

261E12



Rubinetto a T normale, 3/8x3/4, 1/2x3/4.
C.P. brass washing machine bibcock, 3/8x3/4, 1/2x3/4.

26512 1/2x3/4

26538 3/8x3/4



Filtro per tubi carico lavatrice, 3/4Mx3/4F.
C.P. filter for washing machine inlet hose, 3/4Mx3/4F.

280

VALVOLE
VALVES

RACCORDERIA
FITTINGS

ACCESSORI
ACCESSORIES

COMPONENTI PLASTICI
PLASTIC COMPONENTS

ACCESSORI PER LAVATRICE - WASHING MACHINE ACCESSORIES



Tubo di carico per lavatrice, 3/4F x 3/4F.
Washing machine inlet hose, 3/4F x 3/4F.

290100	100 cm
290150	150 cm
290200	200 cm
290250	250 cm
290300	300 cm



Tubo di carico per lavatrice, con curvetta, 3/4F x 3/4F.
Washing machine inlet hose, with elbow pipe, 3/4F x 3/4F.

291100	100 cm
291150	150 cm
291200	200 cm
291250	250 cm
291300	300 cm
291350	350 cm
291400	400 cm
291500	500 cm



Tubo di carico in treccia acciaio inox gigante, 3/4F x 3/4F.
Washing machine stainless steel inlet hose, 3/4F x 3/4F.

293100	100 cm
293150	150 cm
293200	200 cm
293250	250 cm



Tubo di carico con treccia in nylon bianco con banda grigia e curvetta, 3/4F x 3/4F.
Washing machine braided in white nylon with grey stripes inlet hose and elbow pipe, 3/4F x 3/4F.

296100	100 cm
296150	150 cm
296200	200 cm
296250	250 cm



Tubo di carico in treccia acciaio inox gigante con curvetta, 3/4F x 3/4F.
Washing machine stainless steel inlet hose with elbow pipe, 3/4F x 3/4F.

294100	100 cm
294150	150 cm
294200	200 cm
294250	250 cm



Tubo di scarico per lavatrice, in plastica, spiralato e supporto in plastica, Art 305+305SU in sacchetto.
Washing machine outlet hose, in plastic, with elbow holder, Art 305+305SU, in plastic bag.

305150BA	150 cm
305200BA	200 cm
305250BA	250 cm
305300BA	300 cm



Sifone di scarico per lavatrice, in plastica, con scarico ad innesto o a saldare, Ø mm 40.
Built-in washing machine siphon in black PEHD, outlet to weld or to insert Ø 40 mm.

300



Sifone di scarico per lavatrice, in plastica, con scarico ad incollare, Ø mm 32, 40.
Built-in washing machine siphon in grey PVC, to glue Ø 32, 40 mm.

300INC



Sifone di scarico per lavatrice, in plastica, con piastra in acciaio INOX lucidato, con scarico ad innesto o a saldare, Ø mm 40.
Built-in washing machine siphon in black PEHD, with polished stainless steel flange, outlet to weld or to insert Ø 40 mm.

300X



Tubo di scarico per lavatrice, in plastica, spiralato.
Washing machine outlet hose, in plastic.

305100	100 cm
305150	150 cm
305200	200 cm
305250	250 cm
305300	300 cm
305350	350 cm
305400	400 cm
305500	500 cm



Tubo di scarico per lavatrice in plastica spiralato, con raccordi Ø 22x29.
Washing machine outlet hose, in plastic, with connection Ø 22x29.

305B100	100 cm
305B150	150 cm
305B200	200 cm
305B250	250 cm
305B300	300 cm



Tubo di scarico per lavatrice in plastica spiralato, con raccordo curvo.
Washing machine outlet hose, in plastic, with elbow connection.

305C100	100 cm
305C150	150 cm
305C200	200 cm
305C250	250 cm
305C300	300 cm
305C350	350 cm
305C400	400 cm
305C500	500 cm



Raccordo a Y in propilene con dado girevole, 3/4Fx3/4Mx3/4M.
Y propylene connection with movable nut 3/4Fx3/4Mx3/4M.

298



Nipples in nylon, 3/4.
Nipples in nylon, 3/4

297



Tubo scarico lavatrice, in plastica estensibile da cm 60 a cm 200.
Extendable corrugate outlet hose for washing machine from cm 60 to cm 200.

306ES60

Tubo scarico lavatrice, in plastica estensibile da cm 70 a cm 270.
Extendable corrugate outlet hose for washing machine from cm 70 to cm 270.

306ES70

Tubo scarico lavatrice, in plastica estensibile da cm 120 a cm 400.
Extendable corrugate outlet hose for washing machine from cm 120 to cm 400.

306ES120



Giunto in nylon per tubi scarico.
Connection in nylon for waste tubes.

3081717	Ø 17x17
3081720	Ø 17x20
3082020	Ø 20x20



Supporto in plastica per art. 305.
Plastic elbow holder for art. 305.

305SU

RUBINETTERIA
TAPS

FLESSIBILI
FLEXIBLE HOSES

MINUTERIA
MINUTERY

VALVOLE
VALVES

RACCORDERIA
FITTINGS

ACCESSORI
ACCESSORIES

COMPONENTI PLASTICI
PLASTIC COMPONENTS



VALVOLE VALVES



VALVOLE - VALVES

RUBINETTERIA
TAPS

FLESSIBILI
FLEXIBLE HOSES

MINUTERIA
MINUTERY

VALVOLE
VALVES

RACCORDERIA
FITTINGS

ACCESSORI
ACCESSORIES

COMPONENTI PLASTICI
PLASTIC COMPONENTS

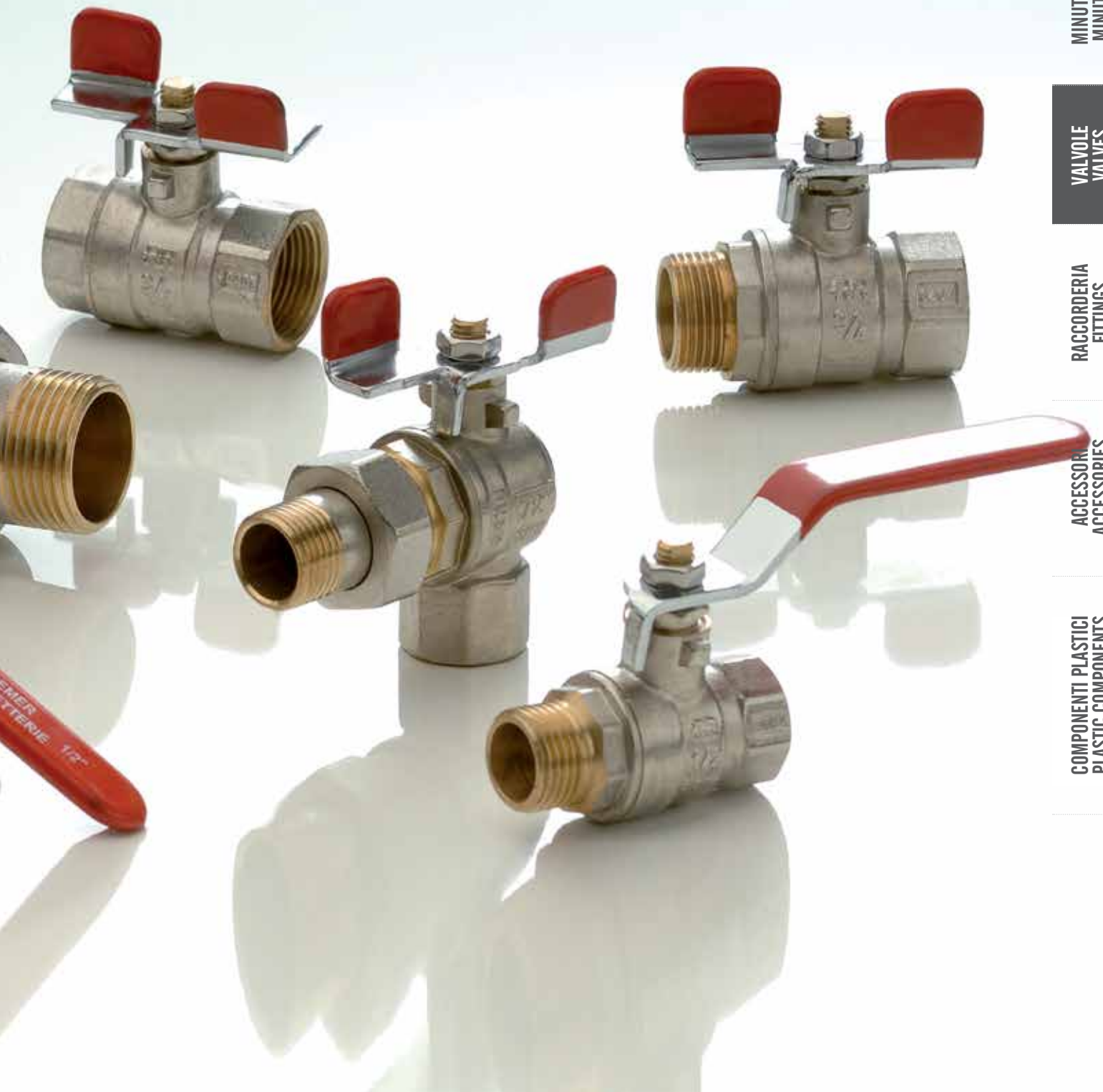

SERIE SEVEN | SEVEN SERIE

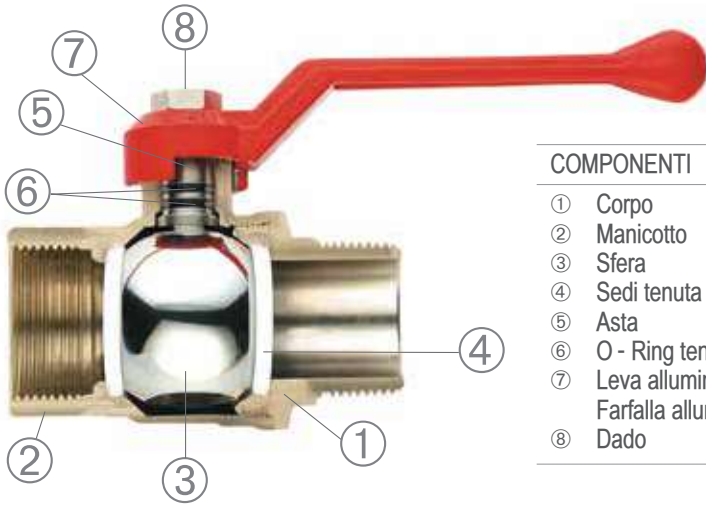

COMPONENTI	COMPONENTS	MATERIALI - MATERIALS
① Corpo	① Body	UNI EN 12165 CW617N
② Manicotto	② End connection	UNI EN 12165 CW617N
③ Sfera	③ Ball	UNI EN 12165 CW617N
④ Sedi tenuta sfera	④ Ball seal	P.T.F.E.
⑤ Asta	⑤ Stem	UNI EN 12164 CW614N
⑥ O - Ring tenuta asta	⑥ Rod seal O - Ring	NBR 70 Sh A (ASTM D 2240)
⑦ Leva alluminio	⑦ Alu handle	AL fire painted
Farfalla alluminio	Butterfly handle	AL fire painted
⑧ Dado	⑧ Nut	Chrome plated Brass

Condizioni d'esercizio: Temperatura: min -15, max +120 - Pressione nominale: max 40 bar.

- Passaggio: totale
- Gamma: da 1/2" a 2"
- Attacco femmina: filettatura ISO 7/1 Rp (parallela) (DIN 2999)
- Attacco maschio: filettatura ISO 7/1 R (conica) (DIN 2999)
- Codolo e dado: filettatura ISO 228/1 (DIN 259)

Working details: Temperature: min -15, max +120 - Nominal pressure: max 40 bar.

- Flow: full
- Range: from 1/2" till 2"
- Female thread: threading ISO 7/1 R (parallel) (DIN 2999)
- Male thread: threading ISO 7/1 R (conical) (DIN 2999)
- Connection fitting and nut: threading ISO 228/1 (DIN 259)

Diagramma perdite di carico/portata - Load losses/flow rate graph



Diagramma pressione/temperatura - Pressure/temperature graph



364C

1/2

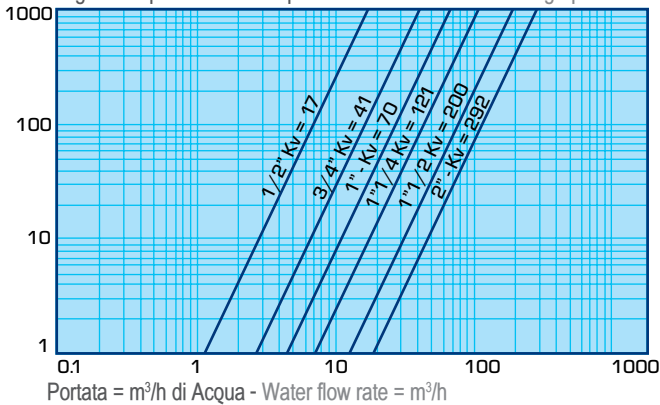
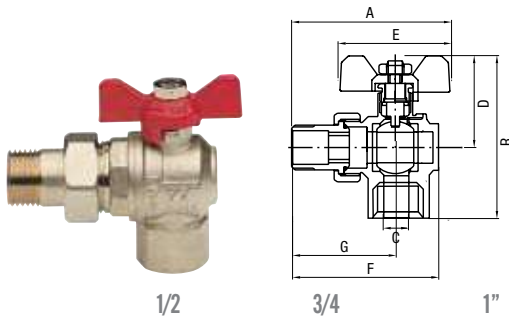
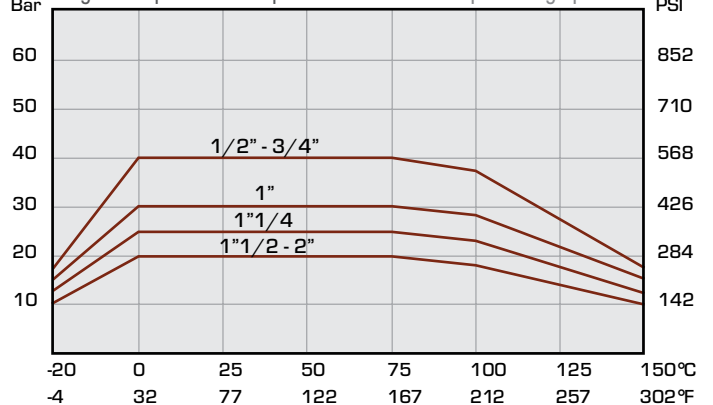
3/4

1"

Valvola a sfera ad angolo a sette filetti, con bocchettone, passaggio totale, maniglia a farfalla.

C.P. full-flow angle ball valve "seven threads", with union connection, with T handle.

	A	B	C	D	E	F	G
1/2"	87	53	15	37,5	51,5	91	61,5
3/4"	96,5	62,5	20	43,5	62	99	66,5
1"	109,5	70	25	46,5	62	118	78,5

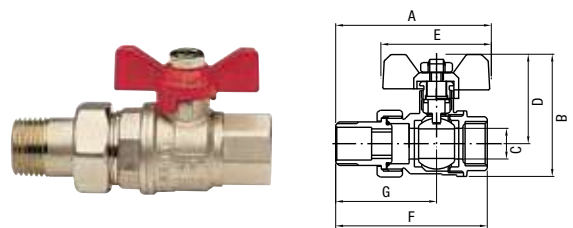

364

1/2

3/4

1"

Valvola a sfera a sette filetti, con bocchettone, passaggio totale, maniglia a farfalla.

C.P. full-flow ball valve "seven threads", with union connection, with T handle.

	A	B	C	D	E	F	G
1/2"	84	69,5	13,8	38	51,5	74,5	58,5
3/4"	96,5	81,5	18,5	45	62	85,5	66
1"	111,5	93	23	48	62	103,5	80

SERIE RR | RR SERIE

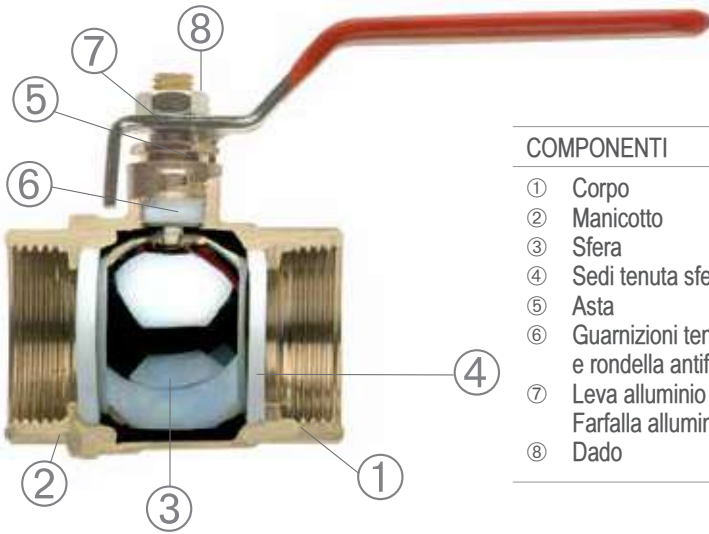

COMPONENTI	COMPONENTS	MATERIALI - MATERIALS
① Corpo	① Body	UNI EN 12165 CW617N
② Manicotto	② End connection	UNI EN 12165 CW617N
③ Sfera	③ Ball	UNI EN 12165 CW617N
④ Sedi tenuta sfera	④ Ball seal	P.T.F.E.
⑤ Asta	⑤ Stem	UNI EN 12164 CW614N
⑥ Guarnizioni tenuta asta e rondella antifrizione	⑥ Stem packing and antifriction ring	P.T.F.E.
⑦ Leva alluminio	⑦ Alu handle	AISI A3 PVC cover
⑧ Farfalla alluminio	⑧ Butterfly handle	AISI A3 PVC cover
⑧ Dado	⑧ Nut	Chrome plated Brass

Condizioni d'esercizio: Temperatura: min -15, max +120 - Pressione nominale: max 40 bar.

- Passaggio: totale
- Gamma: da 1/2" a 2"
- Attacco femmina: filettatura ISO 228/1 (DIN 259)
- Attacco maschio: filettatura ISO 228/1 (conica) (DIN 259)
- Codolo e dado: filettatura ISO 228/1 (DIN 259)

Working details: Temperature: min -15, max +120 - Nominal pressure: max 40 bar.

- Flow: full
- Range: from 1/2" to 2"
- Female thread: threading ISO 228/1 (DIN 259)
- Male thread: threading ISO 228/1 (DIN 259)
- Connection fitting and nut: threading ISO 228/1 (DIN 259)

Diagramma perdite di carico/portata - Load losses/flow rate graph



Diagramma pressione/temperatura - Pressure/temperature graph



371RR 1/2" 3/4" 1" 1 1/4"
1 1/2" 2" 2 1/2" 3" 4"

Valvola a sfera F.F. a passaggio totale, maniglia a leva, linea pesante e ottone visibile. C.p. full-flow RR ball valve F.F., heavy line and visible brass with lever handle.

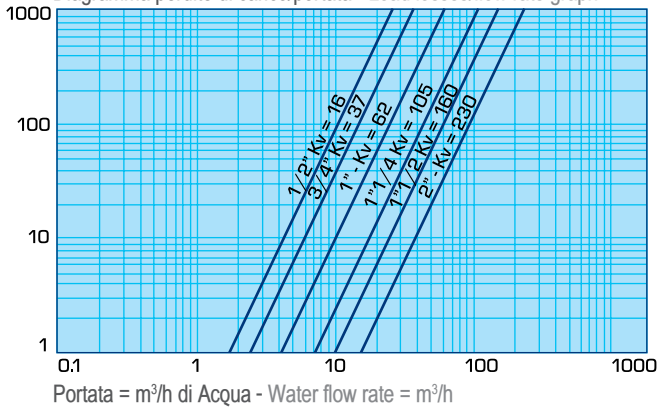
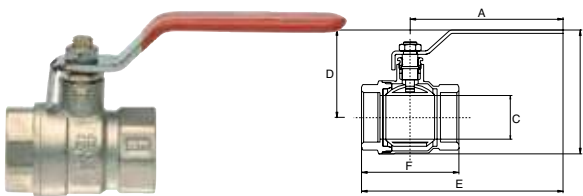
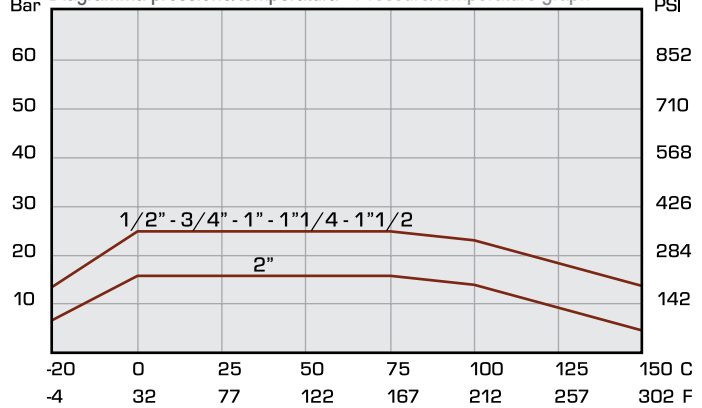
	A	B	C	D	E	F	G
1/2"	95	65	14,5	50	120	48	
3/4"	95	68	18,5	53	124	55	
1"	125	80	23	62	155	63	
1 1/4"	125	97	31,5	69	165	78	
1 1/2"	138	110	31,5	80	180	87	
2"	165	125	50	86	210	100	
2 1/2"	236		62	117	306	140	
3"	225		73	130	330	150	
4"	225		79	142,5	350	190	

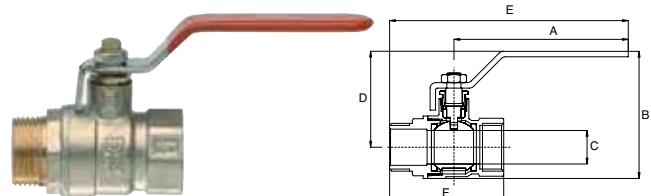

370RR 1/2" 3/4" 1" 1 1/4" 2"

Valvola a sfera M.F. a passaggio totale, maniglia a leva, linea pesante e ottone visibile. C.p. full-flow RR ball valve M.F. heavy line and visible brass with lever handle.

	A	B	C	D	E	F	G
1/2"	95	65	14,5	50	120	63	
3/4"	95	68	18,5	53	130	63	
1"	125	80	23	62	165	72	
1 1/4"	125	97	31,5	69	175	87	
1 1/2"	138	110	31,5	80	195	97	
2"	165	125	50	86	220	110	

RUBINETTERIA
TAPS

FLESSIBILI
FLEXIBLE HOSES

MINUTERIA
MINUTERY

VALVOLE
VALVES

RACCORDERIA
FITTINGS

ACCESSORI
ACCESSORIES

COMPONENTI PLASTICI
PLASTIC COMPONENTS

SERIE FULL FLOW | FULL FLOW SERIE

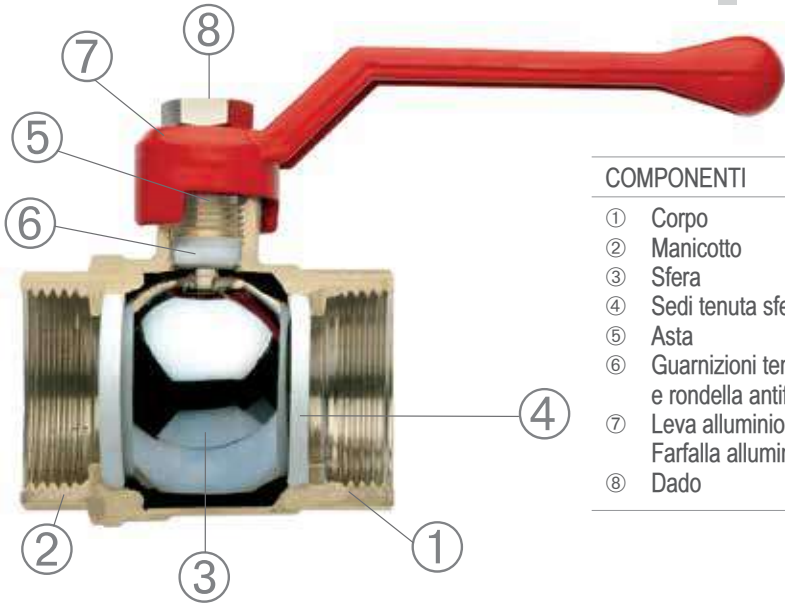

COMPONENTI	COMPONENTS	MATERIALI - MATERIALS
① Corpo	① Body	UNI EN 12165 CW617N
② Manicotto	② End connection	UNI EN 12165 CW617N
③ Sfera	③ Ball	UNI EN 12165 CW617N
④ Sedi tenuta sfera	④ Ball seal	P.T.F.E.
⑤ Asta	⑤ Stem	UNI EN 12164 CW614N
⑥ Guarnizioni tenuta asta e rondella antifrizione	⑥ Stem packing and antifriction ring	P.T.F.E.
⑦ Leva alluminio	⑦ Alu handle	AL fire painted
Farfalla alluminio	Butterfly handle	AL fire painted
⑧ Dado	⑧ Nut	Chrome plated Brass

Condizioni d'esercizio: Temperatura: min -15, max +120 - Pressione nominale: max 40 bar.

- Passaggio: totale
- Gamma: da 3/8" a 4"
- Attacco femmina: filettatura ISO 228/1 (DIN 259)
- Attacco maschio: filettatura ISO 228/1 (DIN 259)
- Codolo e dado: filettatura ISO 228/1 (DIN 259)

Diagramma perdite di carico/portata
Load losses/flow rate graph

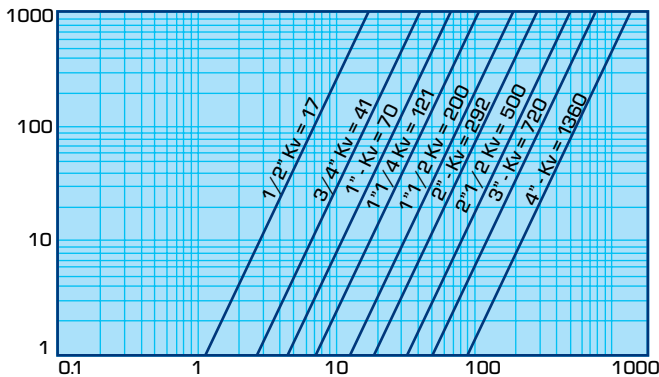

Portata = m³/h di Acqua
Water flow rate = m³/h

Working details: Temperature: min -15, max +120 - Nominal pressure: max 40 bar.

- Flow: full
- Range: from 3/8" till 4"
- Female thread: threading ISO 228/1 (DIN 259)
- Male thread: threading ISO 228/1 (DIN 259)
- Connection fitting and nut: threading ISO 228/1 (DIN 259)

Diagramma pressione/temperatura
Pressure/temperature graph

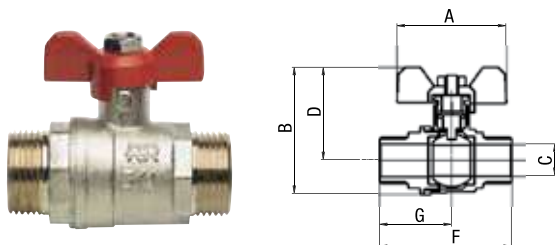
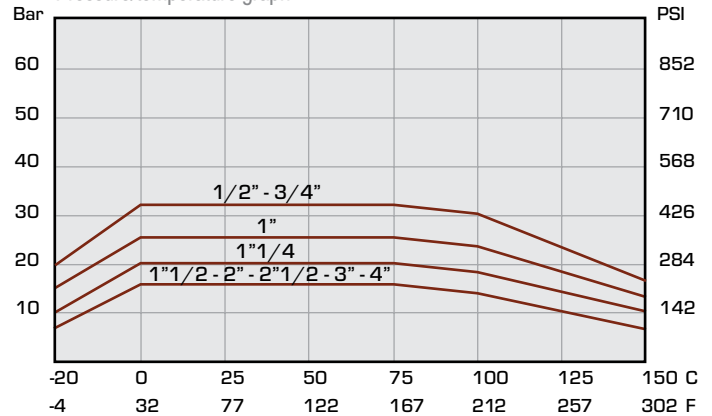

365MM

1/2 3/4 1"

Valvola a sfera M.M., a passaggio totale, maniglia a farfalla.
C.P. full-flow ball valve M.M. with T handle.

	A	B	C	D	E	F	G
1/2"	58,5	53	14,5	38	51	60,5	33
3/4"	61	57,8	18,5	40,5	51	68,5	35,5
1"	71	68,8	23,5	47,8	62	78	40

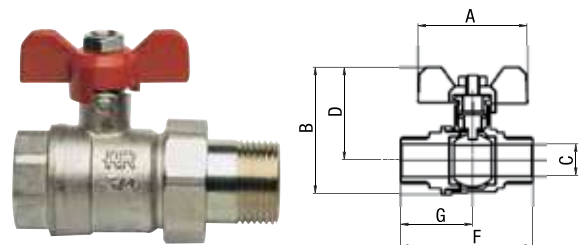

366

1/2 3/4 1" 1 1/4"

Valvola a sfera con bocchettone, a passaggio totale, maniglia a farfalla.
C.P. full-flow ball valve with union connection.

	A	B	C	D	E	F	G
1/2"	78	55	14	38	58	73	48
3/4"	85	60	19	42	58	82	55
1"	98	70	25	45	58	98	65
1 1/4"	110	87	25	60	77	110	72

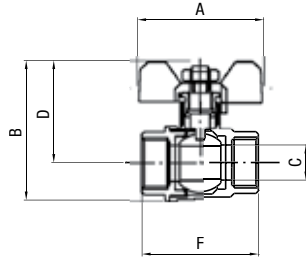

365FF 1/2 3/4 1"

Valvola a sfera F.F., a passaggio totale, maniglia a farfalla.
C.P. full-flow ball valve F.F. with T handle.

	A	B	C	D	E	F	G
1/2"	50	55	14	40		48	
3/4"	50	59	19	42		56	
1"	66	69	25	49		65	

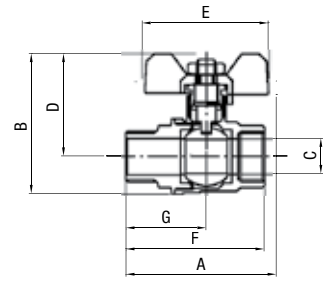

365MF 1/2 3/4 1"

Valvola a sfera M.F., a passaggio totale, maniglia a farfalla.
C.P. full-flow ball valve M.F. with T handle.

	A	B	C	D	E	F	G
1/2"	68	55	14	40	58	57	34
3/4"	65	60	19	43	58	64	37
1"	72	67	24	48	66	72	41

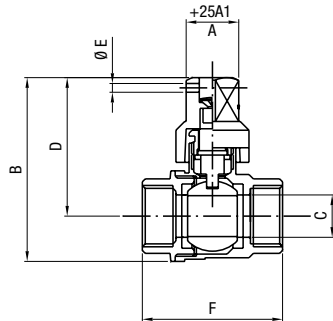

373FF 1/2

Valvola a sfera F.F., a passaggio totale con quadro 13x13 bloccante piombabile.
C.P. full-flow ball valve F.F. with square cap 13x13.

	A	B	C	D	E	F	G
1/2"	14	63	14	47	3,2	48	

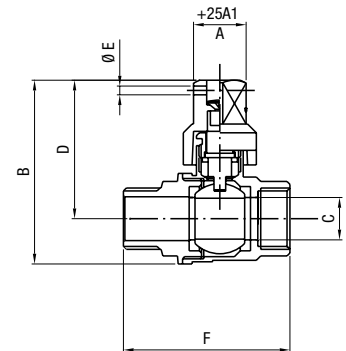

373MF 1/2

Valvola a sfera M.F., a passaggio totale con quadro 13x13 bloccante piombabile.
C.P. full-flow ball valve M.F. with square cap 13x13.

	A	B	C	D	E	F	G
1/2"	14	65	14	47	3,2	64	
3/4"	14	68	19	50	3,2	63	
1"	16	75	24	53	3,2	71	

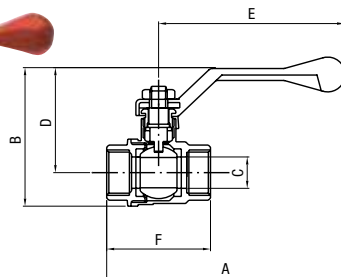

371 3/8 1/2 3/4 1" 1 1/4
1 1/2 2" 2 1/2 3" 4"

Valvola a sfera F.F., a passaggio totale, maniglia a leva.
C.P. full-flow ball valve F.F. with lever handle.

	A	B	C	D	E	F	G
3/8"	96	50	10	38	76	40	
1/2"	110	57	14	42	85	48	
3/4"	113	66	19	50	85	56	
1"	130	75	24	52	98	65	
1 1/4	155	90	31	68	115	78	
1 1/2	178	110	39	80	130	95	
2"	183	123	50	85	132	102	
2 1/2	296	170	60	110	225	136	
3"	305	180	70	120	230	150	
4"	320	205	90	135	230	190	

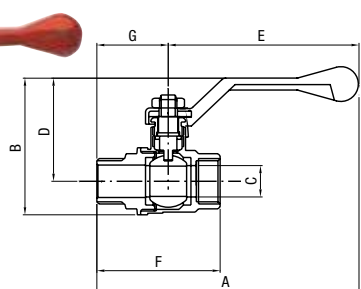

370 1/2 3/4 1"
1 1/4 1 1/2 2"

Valvola a sfera M.F., a passaggio totale, maniglia a leva.
C.P. full-flow ball valve M.F. with lever handle.

	A	B	C	D	E	F	G
1/2"	117	58	14	43	85	57	34
3/4"	120	62	19	44	85	63	37
1"	135	75	24	53	96	72	41
1 1/4	165	93	30	68	118	88	50
1 1/2	186	110	40	80	132	98	56
2"	195	125	50	83	132	112	62

RUBINETTERIA
TAPS

FLESSIBILI
FLEXIBLE HOSES

MINUTERIA
MINUTERY

VALVOLE
VALVES

RACCORDERIA
FITTINGS

ACCESSORI
ACCESSORIES

COMPONENTI PLASTICI
PLASTIC COMPONENTS

SERIE STANDARD | STANDARD SERIE

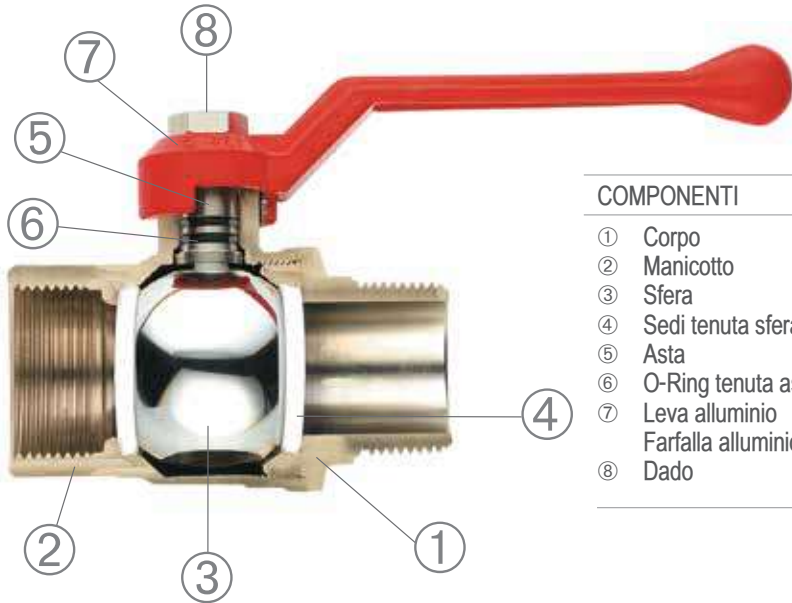

COMPONENTI	COMPONENTS	MATERIALI - MATERIALS
① Corpo	① Body	UNI EN 12165 CW617N
② Manicotto	② End connection	UNI EN 12165 CW617N
③ Sfera	③ Ball	UNI EN 12165 CW617N
④ Sedi tenuta sfera	④ Ball seal	P.T.F.E.
⑤ Asta	⑤ Stem	UNI EN 12164 CW614N
⑥ O-Ring tenuta asta	⑥ Rod seal O-Ring	NBR 70 Sh A (ASTM D 2240)
⑦ Leva alluminio Farfalla alluminio	⑦ Alu handle Butterfly handle	AL fire painted
⑧ Dado	⑧ Nut	Chrome plated Brass

Condizioni d'esercizio: Temperatura: min -15, max +120 - Pressione nominale: max 40 bar.

Working details: Temperature: min -15, max +120 - Nominal pressure: max 40 bar.

- Passaggio: standard
- Gamma: da 1/2" a 2"
- Attacco femmina: filettatura ISO 228/1 (DIN 259)
- Attacco maschio: filettatura ISO 228/1 (DIN 259)

- Flow: standard
- Range: from 1/2" to 2"
- Female thread: threading ISO 228/1 (DIN 259)
- Male thread: threading ISO 228/1 (DIN 259)

Diagramma perdite di carico/portata
Load losses/flow rate graph



Diagramma pressione/temperatura
Pressure/temperature graph



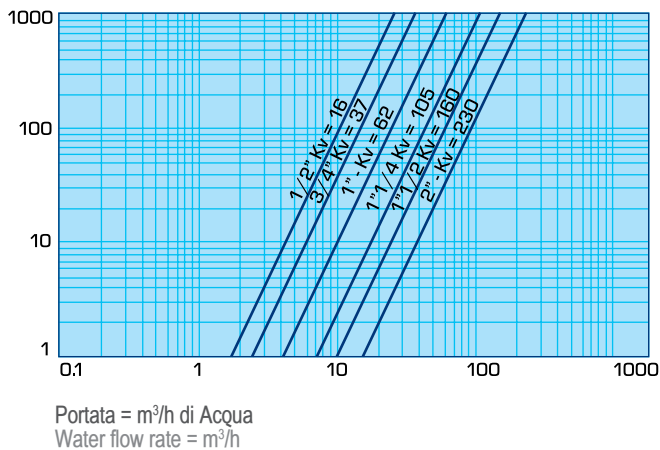
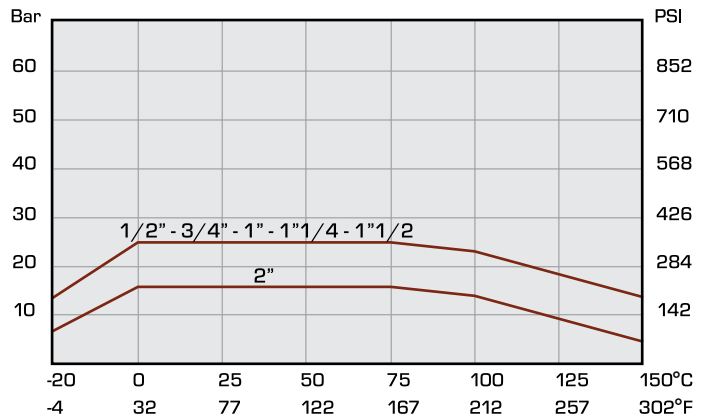
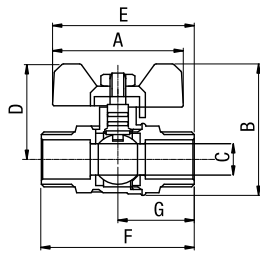

363MM

1/2

3/4

Valvola a sfera M.M., a passaggio standard, maniglia a farfalla, 1/2, 3/4.
C.P. standard-flow ball valve M.M. with T handle, 1/2, 3/4.

	A	B	C	D	E	F	G
1/2"	51,5	51,8	13,8	37	54,6	53	29,2
3/4"	51,5	58,5	17,8	41	58,5	59,5	32,8

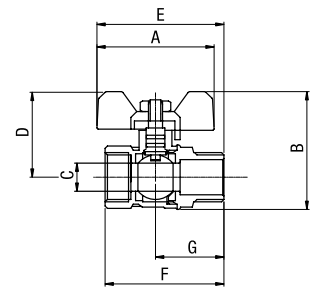

363MF

1/2

Valvola a sfera M.F., a passaggio standard, maniglia a farfalla, 1/2.
C.P. standard-flow ball valve M.F. with T handle, 1/2.

	A	B	C	D	E	F	G
1/2"	47	50	13,5	36	50	45	

RUBINETTERIA
TAPS

FLESSIBILI
FLEXIBLE HOSES

MINUTERIA
MINUTERY

VALVOLE
VALVES

RACCORDERIA
FITTINGS

ACCESSORI
ACCESSORIES

COMPONENTI PLASTICI
PLASTIC COMPONENTS

SERIE REDUCE FLOW | REDUCE FLOW SERIE

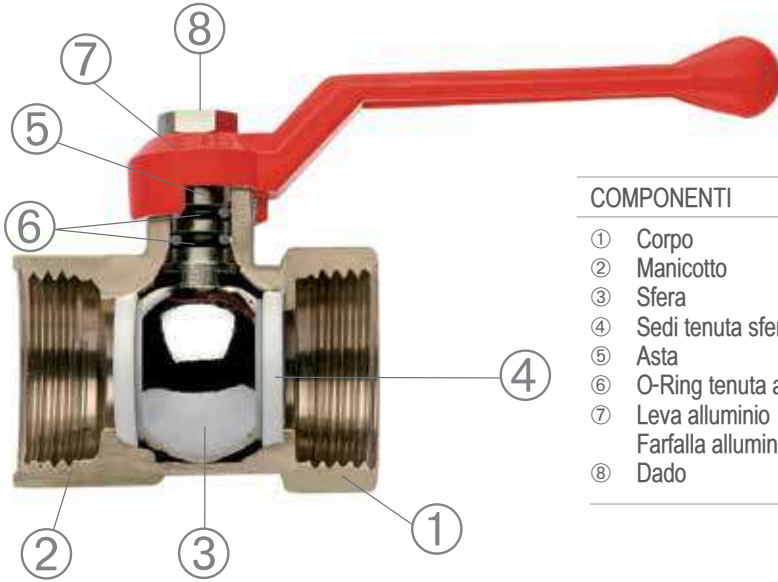

COMPONENTI	COMPONENTS	MATERIALI - MATERIALS
① Corpo	① Body	UNI EN 12165 CW617N
② Manicotto	② End connection	UNI EN 12165 CW617N
③ Sfera	③ Ball	UNI EN 12165 CW617N
④ Sedi tenuta sfera	④ Ball seal	P.T.F.E.
⑤ Asta	⑤ Stem	UNI EN 12164 CW614N
⑥ O-Ring tenuta asta	⑥ Rod seal O-Ring	NBR 70 Sh A (ASTM D 2240)
⑦ Leva alluminio Farfalla alluminio	⑦ Alu handle Butterfly handle	AL fire painted
⑧ Dado	⑧ Nut	Chrome plated Brass

Condizioni d'esercizio: Temperatura: min -15, max +120 - Pressione nominale: max 40 bar.

- Passaggio: ridotto
- Gamma: da 1/2" a 4"
- Attacco femmina: filettatura ISO 228/1 (DIN 259)
- Attacco maschio: filettatura ISO 228/1 (DIN 259)

Working details: Temperature: min -15, max +120 - Nominal pressure: max 40 bar.

- Flow: reduced
- Range: from 1/2" to 4"
- Female thread: threading ISO 228/1 (DIN 259)
- Male thread: threading ISO 228/1 (DIN 259)

Diagramma perdite di carico/portata - Load losses/flow rate graph

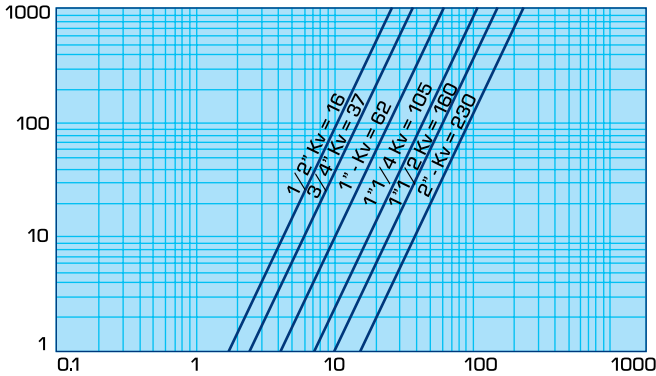

Portata = m³/h di Acqua - Water flow rate = m³/h

Diagramma pressione/temperatura - Pressure/temperature graph

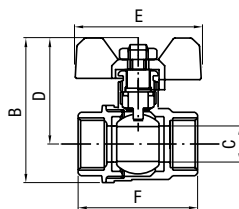
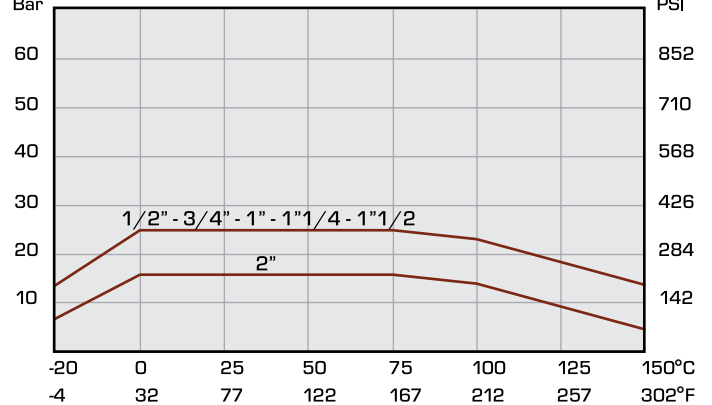

368FF

1/2

3/4

Valvola a sfera F.F. maniglia a farfalla.
C.P. ball valve F.F., with T handle.

	A	B	C	D	E	F	G
1/2"	47	33	58	44			
3/4"	53	36	58	48			

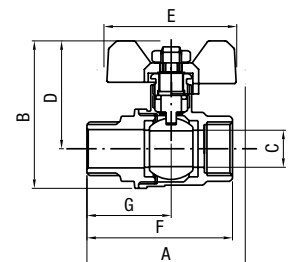

368MF

1/2

3/4

Valvola a sfera F.F. maniglia a farfalla.
C.P. ball valve F.F., with T handle.

	A	B	C	D	E	F	G
1/2"	61	46	12	33	58	53	32
3/4"	64	53	15	36	58	58	34

VALVOLE | VALVES

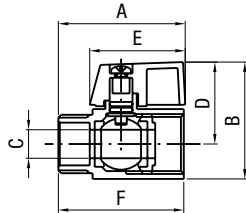
RUBINETTERIA
TAPSFLESSIBILI
FLEXIBLE HOSESMINUTERIA
MINUTERYVALVOLE
VALVESRACCORDERIA
FITTINGSACCESSORI
ACCESSORIESCOMPONENTI PLASTICI
PLASTIC COMPONENTS**372MF**

1/4

3/8

1/2

Valvola minisfera M.F., con maniglia nera.
C.P. mini ball valve M.F. with black handle.

	A	B	C	D	E	F	G
1/4"	42	38	7,5	28	33	41	
3/8"	42	38	8	28	33	41	
1/2"	45	40	10	28	33	44	

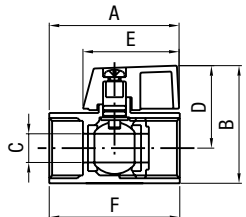
**372FF**

1/4

3/8

1/2

Valvola minisfera F.F., con maniglia nera.
C.P. mini ball valve F.F. with black handle.

	A	B	C	D	E	F	G
1/4"	44	38	7,5	28	33	42	
3/8"	44	38	8	28	33	42	
1/2"	45	40	10	28	33	45	

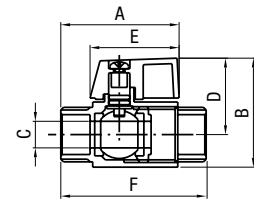
**372MM**

1/2

Valvola minisfera M.M., con maniglia nera.
C.P. mini ball valve M.M. with black handle.

	A	B	C	D	E	F	G
1/2"	45	40	10	28	33	59	

Condizioni d'esercizio: Temperatura: min -15, max +120 - Pressione nominale: max 10 bar.
Working details: Temperature: min -15, max +120 - Nominal pressure: max 10 bar.

**372MF12NC**

Valvola minisfera M.F. maniglia cromata e nera, 1/2.
C.P. mini ball valve M.F. with two handles chromed and black, 1/2.

**372FF12NC**

Valvola minisfera F.F. maniglia cromata e nera, 1/2.
C.P. mini ball valve F.F. with two handles chromed and black, 1/2.

**372MF12RB**

Valvola minisfera M.F. maniglia rossa e blu, 1/2.
C.P. mini ball valve M.F. with two handles red and blue, 1/2.

**372FF12RB**

Valvola minisfera F.F. maniglia rossa e blu, 1/2.
C.P. mini ball valve F.F. with two handles red and blue, 1/2.



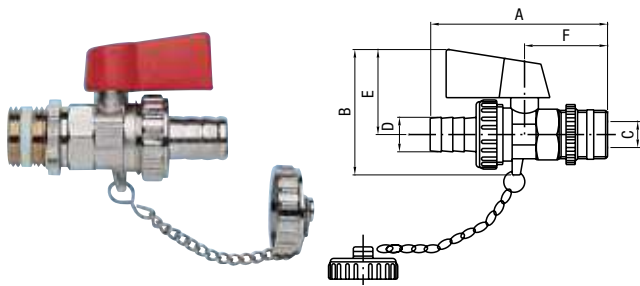

37712

Rubinetto scarico caldaia, a sfera, nichelato 1/2.
 Drain cock male connection with plug, nickel plated, 1/2.

	A	B	C	D	E	F	G
1/2"	77	52	10	15	35	36	

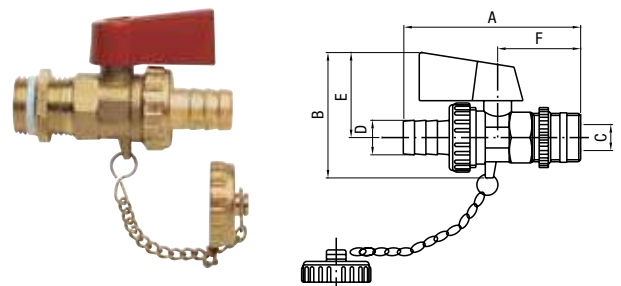

3770G12

Rubinetto scarico caldaia, a sfera, in ottone giallo 1/2.
 Drain cock male connection with plug, brass finish, 1/2.

	A	B	C	D	E	F	G
1/2"	77	52	10	15	35	36	

Condizioni d'esercizio: Temperatura: min 0, max +80 - Pressione nominale: max 12 bar.
 Working details: Temperature: min 0, max +80 - Nominal pressure: max 12 bar.

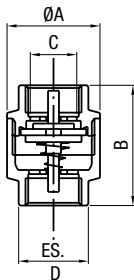

380

Valvola di ritegno.
 REMER check valve.

1/2	1"1/4
3/4	1"1/2
1"	2"

	A	B	C	D	E	F	G
1/2"	35	45	19	25			
3/4"	40	48	24	32			
1"	47	56	30	37			
1" 1/4	59	61	39	46			
1" 1/2	67	70	45	53			
2"	83	75	55	67			

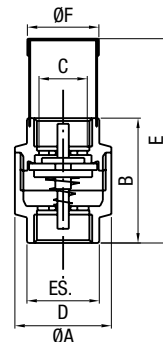

381

Valvola di fondo, con filtro.
 REMER foot valve, with filter.

1/2	1"1/4
3/4	1"1/2
1"	2"

	A	B	C	D	E	F	G
1/2"	34	42	18	25	68	24	
3/4"	44	47	24	31	77	30	
1"	45	52	30	38	89	36	
1" 1/4	59	60	39	46	107	44	
1" 1/2	68	68	44	53	121	54	
2"	84	75	57	67	140	64	

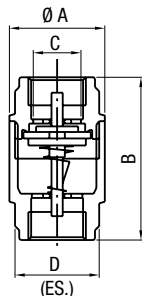

383

Valvola di ritegno STAR.
 STAR check valve.

1/2	1"1/4
3/4	1"1/2
1"	2"

	A	B	C	D	E	F	G
1/2"	33	54	19	27			
3/4"	40	65	24	33			
1"	48	75	30	40			
1" 1/4	60	73	39	50			
1" 1/2	70	87	45	55			
2"	86	94	56	67			



384

Filtro per valvola STAR 1/2, 3/4,
 1", 1"1/4, 1"1/2, 2".
 Filter for STAR check valve 1/2,
 3/4, 1", 1"1/4, 1"1/2, 2".

1/2	1"1/4
3/4	1"1/2
1"	2"

Condizioni d'esercizio: Temperatura: min 0, max +80 - Pressione nominale: max 12 bar.
 Working details: Temperature: min 0, max +80 - Nominal pressure: max 12 bar.

SERIE YELLOW | YELLOW SERIE



Tubo flessibile per gas, FF, conforme alla norma EN14800, tubo interno in acciaio inox, ricoperto da trecciatura inox e rivestito da una guaina in pvc.
Flexible tube for gas, FF, conform to EN14800, internal tube in stainless steel, external braided in stainless steel and covered in pvc.

400FF50	50 cm
400FF100	100 cm
400FF150	150 cm
400FF200	200 cm



Tubo flessibile per gas, MF, conforme alla norma EN14800, tubo interno in acciaio inox, ricoperto da trecciatura inox e rivestito da una guaina in pvc.
Flexible tube for gas, MF, conform to EN14800, internal tube in stainless steel, external braided in stainless steel and covered in pvc..

400MF50	50 cm
400MF100	100 cm
400MF150	150 cm
400MF200	200 cm



prodotto non vendibile in italia

Tubo gas inox estensibile ricoperto in polietilene termoretraibile a norma UNI CIG 9891 con marchio IMQ, per collegamento di apparecchiature domestiche.
Flexible extensible stainless steel hose, suitable for domestic use gas connections, in accordance with UNI-CIG 9891, IMQ, covered with yellow thermoshrinkable sleeving.

400MFRI50100	1/2 MF	50-100 cm
400MFRI75150	1/2 MF	75-150 cm
400MFRI10020	1/2 MF	100-200 cm



prodotto non vendibile in italia

Tubo gas inox estensibile ricoperto in polietilene termoretraibile a norma UNI CIG 9891 con marchio IMQ, per collegamento di apparecchiature domestiche.
Flexible extensible stainless steel hose, suitable for domestic use gas connections, in accordance with UNI-CIG 9891, IMQ, covered with yellow thermoshrinkable sleeving.

400FFRI50100	1/2 FF	50-100 cm
400FFRI75150	1/2 FF	75-150 cm
400FFRI10020	1/2 FF	100-200 cm



Rubinetto a sfera a squadra per gas liquido GPL, cromato M, 1/2.
C.P. angle ball valve for liquid gas GPL, 1/2M.

40312



Rubinetto gas a sfera a squadra passaggio mm 12,5 con maniglia a farfalla, 1/2 MM.
Angle ball valve for natural gas with T handle, flow Ø 12,5, 1/2M.

39912



Rubinetto a sfera a squadra per gas, con dado girevole, cromato, F 1/2.
C.P. angle ball valve for gas, with swivelling nut, F 1/2.

411F12



Rubinetto a sfera diritto per gas liquido GPL, cromato M, 1/2.
C.P. straight ball valve for liquid gas GPL, 1/2M.

40712



Tubo inox estensibile antivibrante, adatto per gas, acqua, olii, acidi, aria, vapore.
Stainless steel extensible anti-vibration pipe, suitable for gas, water, oils, acids, air, steam.

44012110	1/2 MF	110-210 cm
44012200	1/2 MF	200-410 cm
44034110	3/4 MF	110-210 cm
44034200	3/4 MF	200-410 cm
44010110	1" MF	110-210 cm
44010200	1" MF	200-410 cm



Tubo inox estensibile rivestito in polietilene termoretraibile.
Stainless steel extensible pipe, covered with heat-shrinkable polyethylene.

440RI12110	1/2 MF	110-210 cm
440RI12200	1/2 MF	200-410 cm
440RI34110	3/4 MF	110-210 cm
440RI34200	3/4 MF	200-410 cm



Tubo gas a norme UNI CIG 7140 - IMQ, Ø 8x13, per gas liquido GPL, in rotoli da mt 50.
Tube for liquid gas GPL, UNI CIG 7140 and IMQ standard rules, Ø 13x8mm, in rolls of 50 meters.

397



Guarnizione in alluminio, 1/2 per art. 400.
Washer in aluminium, 1/2 for art. 400.

400GU



RACCORDERIA FITTINGS



RACCORDERIA - FITTINGS

RUBINETTERIA
TAPS

FLESSIBILI
FLEXIBLE HOSES

MINUTERIA
MINUTERY

VALVOLE
VALVES

RACCORDERIA
FITTINGS

ACCESSORI
ACCESSORIES

COMPONENTI PLASTICI
PLASTIC COMPONENTS



RACCORDERIA - FITTINGS



Valvola sicurezza scaldabagno normale MF, 1/2.
Safety valve for water heaters, normal type, MF 1/2.

413N12 1/2



Valvola sicurezza scaldabagno pesante tarata 8 atmosfere MF 3/8, 1/2.
Safety valve for water heaters, heavy type, set for 8 atmospheres, MF, 3/8, 1/2.

413P812 1/2



Valvola sicurezza scaldabagno pesante MF, 1/2.
Safety valve for water heaters, heavy type, MF 1/2.

41212 1/2



Riduttore di pressione nichelato FF 1/2.
Nickel plated brass pressure reducer, FF 1/2.

41512 1/2



Riduttore di pressione in ottone giallo con bocchettoni.
Yellow heavy brass pressure reducer, with union connection.

415CB12MM 1/2" M x 1/2" M

415CB34MM 3/4" M x 3/4" M

415CB10MM 1" M x 1" M



Manometro Ø mm 63, con attacco radiale 1/4, 10 bar.
Pressure gauge Ø 63 mm, 1/4" radial connection, 10 bar.

418 1/4 - 10 bar



Valvola sfianto aria automatica con galleggiante 3/8, 1/2.
Automatic drain plug for radiator, with floating system, 3/8, 1/2.

43338 3/8

43312 1/2



Manometro Ø mm 63, con attacco posteriore (assiale) 1/4, 10 bar.
Pressure gauge Ø 63 mm, with rear connection (axial) 1/4, 10 bar.

418P 3/48



Bocchettone a 3 pezzi diritto, in ottone giallo.
Straight coupler in 3 pieces, yellow brass.

46112 1/2

46134 3/4

46110 1"

461114 1" 1/4



Bocchettone a 3 pezzi diritto, in ottone cromato.
Straight coupler in 3 pieces, C.P. brass.

461CR12 1/2

461CR34 3/4

461CR10 1"

461CR114 1" 1/4



Bocchettone a 3 pezzi curvo, in ottone giallo.
Angle coupler in 3 pieces, yellow brass.

46212 1/2

46234 3/4

46210 1"

462114 1" 1/4



Bocchettone a 3 pezzi curvo, in ottone cromato.
Angle coupler in 3 pieces, C.P. brass.

462CR12 1/2

462CR34 3/4

462CR10 1"

462CR114 1" 1/4



Raccordo per cassone con tappo.
Flanged connector for cistern with plug.

47112	1/2
47134	3/4
47110	1"



Raccordo per cassone dritto.
Straight connector for cistern.

47312	1/2
47334	3/4
47310	1"



Raccordo per cassone con codolo.
Flanged connector for cistern with union.

47212	1/2
47234	3/4
47210	1"



Controdado con flangia.
Backnut in brass.

47412	1/2
47434	3/4
47410	1"

RACCORDI IN OTTONE - BRASS FITTINGS



Gomito M.F. in ottone cromato.
Elbow M.F., in C.P. brass.

45138	3/8
45112	1/2
45134	3/4
45110	1"



Gomito F.F. in ottone cromato.
Elbow F.F., in C.P. brass.

45238	3/8
45212	1/2
45234	3/4
45210	1"



TE in ottone cromato.
Tee in chrome plated brass.

45338	3/8
45312	1/2
45334	3/4
45310	1"



Manicotto F.F. in ottone cromato.
Sleeve F.F. in chrome plated brass.

45438	3/8
45412	1/2
45434	3/4
45410	1"



Gomito M.F. in ottone giallo.
Elbow M.F., in yellow brass.

451OG38	3/8
451OG12	1/2
451OG34	3/4
451OG10	1"
451OG114	1" 1/4
451OG112	1" 1/2
451OG20	2"



Gomito F.F. in ottone giallo.
Elbow F.F., in yellow brass.

452OG38	3/8
452OG12	1/2
452OG34	3/4
452OG10	1"
452OG114	1" 1/4
452OG112	1" 1/2
452OG20	2"

RUBINETTERIA
TAPS

FLESSIBILI
FLEXIBLE HOSES

MINUTERIA
MINUTERY

VALVOLE
VALVES

RACCORDERIA
FITTINGS

ACCESSORI
ACCESSORIES

COMPONENTI PLASTICI
PLASTIC COMPONENTS

RACCORDERIA - FITTINGS



TE in ottone giallo.
Tee in yellow brass.

453OG38	3/8
453OG12	1/2
453OG34	3/4
453OG10	1"
453OG114	1" 1/4
453OG112	1" 1/2
453OG20	2"



Manicotto F.F. in ottone giallo.
Sleeve F.F. in yellow brass.

454OG38	3/8
454OG12	1/2
454OG34	3/4
454OG10	1"
454OG114	1" 1/4
454OG112	1" 1/2
454OG20	2"



Prolunghe ridotte in ottone cromato.
Round C.P. brass reduced extension.

5061438	1/4 x 3/8
5061412	1/4 x 1/2
5063812	3/8 x 1/2
5063834	3/8 x 3/4
5061234	1/2 x 3/4
5061210	1/2 x 1"
5063410	3/4 x 1"
50610114	1" x 1" 1/4



Prolunghe in ottone cromato tipo pesante, Ø mm 27,
con broccia.
Heavy c.p. brass extension, Ø mm 27.

	mm	
502P1210	10	1/2
502P1215	15	1/2
502P1220	20	1/2
502P1225	25	1/2
502P1230	30	1/2
502P1240	40	1/2
502P1250	50	1/2
502P1260	60	1/2
502P1280	80	1/2
502P12100	100	1/2



Prolunghe in ottone giallo tipo pesante Ø mm 27,
con broccia.
Heavy yellow brass extension Ø mm 27.

	mm	
502POG1210	10	1/2
502POG1215	15	1/2
502POG1220	20	1/2
502POG1225	25	1/2
502POG1230	30	1/2
502POG1240	40	1/2
502POG1250	50	1/2
502POG1260	60	1/2
502POG1280	80	1/2
502POG12100	100	1/2



Prolunghe ridotte in ottone giallo.
Round yellow brass reduced extension.

506OG1438	1/4 x 3/8
506OG1412	1/4 x 1/2
506OG3812	3/8 x 1/2
506OG3834	3/8 x 3/4
506OG1234	1/2 x 3/4
506OG1210	1/2 x 1"
506OG3410	3/4 x 1"
506OG10114	1" x 1" 1/4



Manicotto ridotto F.F. in ottone cromato.
Reduced sleeve F.F. in C.P. brass.

5101438	1/4 x 3/8
5103812	3/8 x 1/2
5101234	1/2 x 3/4
5101210	1/2 x 1"
5103410	3/4 x 1"



Riduzioni esagonali in ottone cromato.
Hexagonal reducing piece in chrome plated brass.

5111438	1/4 x 3/8
5111412	1/4 x 1/2
5111434	1/4 x 3/4
5113812	3/8 x 1/2
5113834	3/8 x 3/4
5111234	1/2 x 3/4
5113410	3/4 x 1"



Manicotto ridotto F.F. in ottone giallo.
Reduced sleeve F.F. in yellow brass.

510OG1438	1/4 x 3/8
510OG3812	3/8 x 1/2
510OG1234	1/2 x 3/4
510OG1210	1/2 x 1"
510OG12114	1/2 x 1" 1/4
510OG12112	1/2 x 1" 1/2
510OG3410	3/4 x 1"
510OG34114	3/4 x 1" 1/4
510OG10114	1" x 1" 1/4



Prolunghe in ottone cromato, con broccia.
C.P. brass extension.

	mm	
5023810	10	3/8
5023815	15	3/8
5023820	20	3/8
5023825	25	3/8
5023830	30	3/8
5023840	40	3/8
5023850	50	3/8

	mm	
5021210	10	1/2
5021215	15	1/2
5021220	20	1/2
5021225	25	1/2
5021230	30	1/2
5021240	40	1/2
5021250	50	1/2
5021260	60	1/2
5021280	80	1/2
50212100	100	1/2

	mm	
5023410	10	3/4
5023415	15	3/4
5023420	20	3/4
5023425	25	3/4
5023430	30	3/4
5023440	40	3/4
5023450	50	3/4
5023460	60	3/4
5023480	80	3/4
50234100	100	3/4



Prolunghe in ottone giallo con broccia.
Yellow brass extension.

	mm	
502OG3810	10	3/8
502OG3815	15	3/8
502OG3820	20	3/8
502OG3825	25	3/8
502OG3830	30	3/8
502OG3840	40	3/8
502OG3850	50	3/8

	mm	
502OG1015	15	1"
502OG1020	20	1"
502OG1025	25	1"
502OG1030	30	1"
502OG1040	40	1"
502OG1050	50	1"

	mm	
502OG1210	10	1/2
502OG1215	15	1/2
502OG1220	20	1/2
502OG1225	25	1/2
502OG1230	30	1/2
502OG1240	40	1/2
502OG1250	50	1/2
502OG1260	60	1/2
502OG1280	80	1/2
502OG12100	100	1/2

	mm	
502OG3410	10	3/4
502OG3415	15	3/4
502OG3420	20	3/4
502OG3425	25	3/4
502OG3430	30	3/4
502OG3440	40	3/4
502OG3450	50	3/4
502OG3460	60	3/4
502OG3480	80	3/4
502OG34100	100	3/4



Viti doppie in ottone cromato, con 7 filetti.
Double nipple in c.p. brass, with 7 threads.

520L12	1/2
--------	-----



Tappi esagonali in ottone cromato.
Hexagonal plug in c. p. brass.

52338	3/8
52312	1/2
52334	3/4
52310	1"



Calotte esagonali in ottone cromato.
Hexagonal cap in c. p. brass.

52438	3/8
52412	1/2
52434	3/4
52410	1"

RUBINETTERIA
TAPS

FLESSIBILI
FLEXIBLE HOSES

MINUTERIA
MINUTERY

VALVOLE
VALVES

RACCORDERIA
FITTINGS

ACCESSORI
ACCESSORIES

COMPONENTI PLASTICI
PLASTIC COMPONENTS

RACCORDERIA - FITTINGS



Viti doppie ridotte in ottone cromato, con 7 filetti.
Reduced nipple in C.P. brass, with 7 threads.

515L3812	3/8 x 1/2
515L1234	1/2 x 3/4



Viti doppie ridotte in ottone cromato.
Reduced nipple in C.P. brass.

5151438	1/4 x 3/8
5151412	1/4 x 1/2
5153812	3/8 x 1/2
5153834	3/8 x 3/4
5151234	1/2 x 3/4
5151210	1/2 x 1"
5153410	3/4 x 1"
51534112	3/4 x 1 1/2"



Viti doppie in ottone cromato.
Double nipple in c.p. brass.

52038	3/8
52012	1/2
52034	3/4
52010	1"



Riduzioni esagonali in ottone giallo.
Hexagonal reducing piece in yellow brass.

511OG1438	1/4 x 3/8
511OG1412	1/4 x 1/2
511OG3812	3/8 x 1/2
511OG3834	3/8 x 3/4
511OG3810	3/8 x 1"
511OG1234	1/2 x 3/4
511OG1210	1/2 x 1"
511OG12114	1/2 x 1 1/4"
511OG3410	3/4 x 1"
511OG34114	3/4 x 1 1/4"
511OG34112	3/4 x 1 1/2"
511OG10114	1" x 1 1/4"
511OG10112	1" x 1 1/2"
511OG1020	1" x 2"
511OG114112	1 1/4 x 1 1/2"
511OG11420	1 1/4 x 2"
511OG11220	1 1/2 x 2"



Viti doppie ridotte in ottone giallo.
Reduced nipple in yellow brass.

515OG1438	1/4 x 3/8
515OG1412	1/4 x 1/2
515OG3812	3/8 x 1/2
515OG3834	3/8 x 3/4
515OG1234	1/2 x 3/4
515OG1210	1/2 x 1"
515OG3410	3/4 x 1"
515OG34112	3/4 x 1 1/2"
515OG10114	1" x 1 1/4"
515OG10112	1" x 1 1/2"
515OG1020	1" x 2"
515OG114112	1 1/4 x 1 1/2"
515OG11420	1 1/4 x 2"



Viti doppie in ottone giallo.
Double nipple in yellow brass.

520OG38	3/8
520OG12	1/2
520OG34	3/4
520OG10	1"
520OG114	1 1/4"
520OG112	1 1/2"
520OG20	2"



Calotte esagonali in ottone giallo.
Hexagonal cap in yellow brass.

524OG38	3/8
524OG12	1/2
524OG34	3/4
524OG10	1"



Viti doppie ridotte in ottone giallo, con 7 filetti.
Reduced nipple in yellow brass, with 7 threads.

515LOG3812	3/8 x 1/2
-------------------	-----------



Viti doppie in ottone giallo, con 7 filetti.
Double nipple in yellow brass, with 7 threads.

520LOG12	1/2
-----------------	-----



Tappi esagonali in ottone giallo.
Hexagonal plug in yellow brass.

523OG38	3/8
523OG12	1/2
523OG34	3/4
523OG10	1"

VITI DOPPIE - DOUBLE NIPPLES



Vite doppia in ottone cromato mm 36, 1/2".
Double nipple in c.p. brass mm 36, 1/2".

52112 1/2"



Vite doppia in ottone cromato prolungata mm 50, 1/2".
Double nipple in c.p. brass mm 50, extended 1/2".

52112L 1/2"



Vite doppia in ottone giallo mm 36, 1/2".
Double nipple in yellow brass mm 36, 1/2".

5210G12 3/2"



Vite doppia prolungata in ottone giallo mm 50, 1/2".
Double nipple in yellow brass mm 50, extended 1/2".

5210G12L 1/2"

PORTAGOMMA - HOSE HOLDER



Portagomma diritto in ottone cromato Ø 14 mm, attacco M, 1/2.
Straight hose holder in c.p. brass Ø 14 mm, Male connection, 1/2.

53112



Portagomma diritto in ottone cromato Ø 9 mm, attacco M, 1/2.
Straight hose holder in c.p. brass Ø 9 mm, Male connection, 1/2.

53312



Portagomma diritto in ottone cromato Ø 14 mm, attacco F, 1/2.
Straight hose holder in c.p. brass Ø 14 mm, Female connection, 1/2.

53212



Portagomma curvo in ottone cromato Ø 15 mm, attacco M, 1/2.
Elbow hose holder in c.p. brass Ø 15 mm, Male connection, 1/2.

53612



Portagomma curvo in ottone cromato Ø 15 mm, attacco F, 1/2.
Elbow hose holder in c.p. brass Ø 15 mm, Female connection, 1/2.

53712



Portagomma diritto in ottone cromato Ø 9 mm, attacco F, 1/2.
Straight hose holder in c.p. brass Ø 9 mm, Female connection, 1/2.

53412



Portagomma curvo in ottone cromato Ø 10 mm, attacco M, 1/2.
Elbow hose holder in c.p. brass Ø 10 mm, Male connection, 1/2.

53812



Portagomma curvo in ottone cromato Ø 10 mm, attacco F, 1/2.
Elbow hose holder in c.p. brass Ø 10 mm, Female connection, 1/2.

53912

RUBINETTERIA
TAPS

FLESSIBILI
FLEXIBLE HOSES

MINUTERIA
MINUTERY

VALVOLE
VALVES

RACCORDERIA
FITTINGS

ACCESSORI
ACCESSORIES

COMPONENTI PLASTICI
PLASTIC COMPONENTS

RACCORDI - FITTINGS



Bariotti in ottone giallo, confezione da 10 pezzi.
Yellow brass extension screws, packing of 10 pieces.

	mm	
530OG1260	60	1/2
530OG1280	80	1/2
530OG12100	100	1/2
530OG12120	120	1/2
530OG12150	150	1/2
530OG12200	200	1/2
530OG12300	300	1/2
530OG12500	500	1/2

	mm	
530OG3460	60	3/4
530OG3480	80	3/4
530OG34100	100	3/4
530OG34120	120	3/4

	mm	
530OG1060	60	1"
530OG1080	80	1"
530OG10100	100	1"



Raccordo tutto filettato in ottone cromato.
C.p. brass extension full threaded.

	mm	
5291230	30	1/2
5291250	50	1/2
5291265	65	1/2
5291280	80	1/2
52912100	100	1/2



Raccordo tutto filettato in ottone giallo.
Yellow brass extension full threaded.

	mm	
529OG1230	30	1/2
529OG1250	50	1/2
529OG1280	80	1/2
529OG12100	100	1/2

RACCORDI IN ACCIAIO ZINCATO - GALVANIZED FITTINGS



Prolunghe in acciaio zincato.
Galvanized steel extensions.

	mm	
5013810	10	3/8
5013815	15	3/8
5013820	20	3/8
5013825	25	3/8
5013830	30	3/8

	mm	
5011210	10	1/2
5011215	15	1/2
5011220	20	1/2
5011225	25	1/2
5011230	30	1/2

	mm	
5013410	10	3/4
5013415	15	3/4
5013420	20	3/4
5013425	25	3/4
5013430	30	3/4



Prolunghe ridotte in acciaio zincato.
Reduced extension round, galvanized steel.

506AZ1438	1/4 x 3/8
506AZ3812	3/8 x 1/2
506AZ1234	1/2 x 3/4
506AZ3410	3/4 x 1"



Riduzioni esagonali in acciaio zincato.
Hexagonal reduced extension, galvanized steel.

511AZ1438	1/4 x 3/8
511AZ3812	3/8 x 1/2
511AZ1234	1/2 x 3/4
511AZ3410	3/4 x 1"



Viti doppie ridotte in acciaio zincato.
Reduced nipple, galvanized steel.

515AZ3812	3/8 x 1/2
515AZ1234	1/2 x 3/4
515AZ3410	3/4 x 1"



Manicotti FF in acciaio zincato.
Sleeve FF in galvanized steel.

522AZ38	3/8"
522AZ12	1/2"
522AZ34	3/4"



Viti doppie esagonali in acciaio zincato.
Hexagonal double nipple in galvanized steel.

520AZ14	1/4"
520AZ38	3/8"
520AZ12	1/2"
520AZ34	3/4"
520AZ10	1"



Bariotti in acciaio zincato, confezioni da 10 pezzi.
Galvanized steel extension screws, packing of 10 pieces.

	mm	
5301260	60	1/2
5301280	80	1/2
53012100	100	1/2
53012120	120	1/2
53012150	150	1/2
53012200	200	1/2
53012300	300	1/2
53012500	500	1/2

	mm	
5303460	60	3/4
5303480	80	3/4
53034100	100	3/4
53034120	120	3/4
53034150	150	3/4
53034200	200	3/4
53034300	300	3/4
53034500	500	3/4

	mm	
5301060	60	1"
5301080	80	1"
53010100	100	1"
53010120	120	1"
53010150	150	1"
53010200	200	1"
53010300	300	1"
53010500	500	1"

RUBINETTERIA
TAPS

FLESSIBILI
FLEXIBLE HOSES

MINUTERIA
MINUTERY

VALVOLE
VALVES

RACCORDERIA
FITTINGS

ACCESSORI
ACCESSORIES

COMPONENTI PLASTICI
PLASTIC COMPONENTS

SERIE 495 | 495 SERIE

TUBO MULTISTRATO RR PEX - MULTILAYER PIPE RR PEX



Tubo multistrato RR PEX.
Multilayer pipe RR PEX.

49516 Ø 16x2 mm 100 m

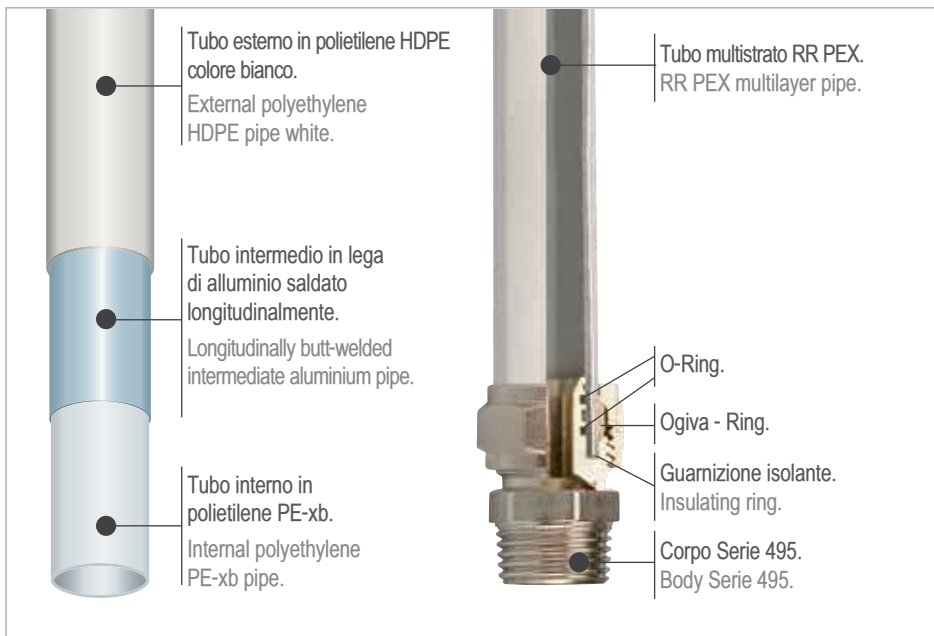

Cesoia taglia tubo.
Pipe cutter.

495CE



Calibratore per tubo.
Pipe plug gauge.

495SB

Analisi del tubo multistrato RR PEX Secondo UNI 10954-1 Analysis of the multilayer pipe RR PEX Conform to UNI 10954-1

ESAME DIMENSIONALE

Misure di spessore degli strati del tubo:

Art.	Dn esterno	Dn interno	S parete n	Tolleranza	Strato esterno media Um	Strato intermedio media Um	Strato interno media Um
495 16	16	12	2	± 0,2	700	300	1.000
495 20	20	16	2	± 0,15	680	320	1.000
495 26	26	20	3	± 0,1	1.085	385	1.530
495 32	32	26	3	± 0,15	900	385	1.715

Gli spessori e le tolleranze degli strati sono conformi a quanto previsto per la serie S, punto 7 UNI 10954/1 prospetti 2/3.

La serie S di appartenenza ad ogni misura è la seguente (16 x 2 = S26) (20 x 2 - 26 x 3 - 32 x 3 corrispondono alla serie S 34,5 / 42.8).

Determinazione della resistenza alla pressione idrostatica secondo UNI 10954-1:2004 e caratteristiche meccaniche.

La prova è stata condotta secondo la norma UNI EN 921:1995 nelle seguenti condizioni:

Pressione idrostatica impostata	20,5 bar (prevista 19,73)
Classe di appartenenza dichiarata	2
Temperatura di prova impostata	95°C
Natura dell'ambiente di prova	Acqua
Tamponi utilizzati	Tipo A
Lunghezza libera del tubo	200 mm.
Durata della prova	1008 h (prevista 1000 h)
Posizione provino	Verticale

Incertezza di misura espressa come deviazione std.: pressione ±0,1 bar, temperatura ±1,4°C.

I risultati ottenuti sono i seguenti:

REQUISITO PROVA TEST REQUIREMENT	VALORE OTTENUTO VALUE OBTAINED	ESITO DELLA PROVA TEST RESULT	TIPO DI ROTTURA KIND OF BREAKING
NESSUNA ROTTURA PER LA DURATA PROVA NO BREAKING FOR ALL THE TESTING TIME	Nessuna rottura No breaking	Positivo Positive	-- --

Caratteristiche fisiche e chimiche

Grado di reticolazione dello strato interno dei test di controllo eseguito sui campioni a norma UNI EN 579 Art 495 16 = 66,4%_ Art 495 20 = 65,8%_ Art 495 26 = 65,7% _ Art 495 32 = 65,6%.

Grado di reticolazione dello strato esterno dei test di controllo eseguiti sui campioni a norma UNI EN 579 Art 495 16 =1,5%_ Art 495 20 = 1,3% _ Art 495 26 = 1% _ Art 495 32 =1,4%.

Secondo quanto previsto da UNI 10954 1 prospetto 5:

- 1) il materiale utilizzato per lo strato interno è PE-Xb mentre per lo strato esterno è HDPE
- 2) lo strato intermedio del tubo multistrato è in alluminio tipo A punto 5,3 norma UNI 10954 / 1
- 3) nessun scollamento si è verificato dopo la prova di Curvatura
- 4) gli strati non si sono separati dopo la prova di svasamento
- 5) l'aderenza degli strati di materiale plastico allo strato intermedio determinata mediante la separazione degli stessi ha dato il seguente esito:

N° prove - N° tests	Dimensioni - Dimension mm	Aderenza - Bonding N/cm
1	10.0	70.3
2	10.0	54.0
3	10.0	46.2
4	10.0	41.1
5	10.0	48.7
Media di 5 provini - Average of 5 tests	10.0	52.1

Il tubo multistrato Art 495 R, dove R sta per ricoperto, si differenzia dal tubo multistrato solo dalla copertura che viene ottenuta utilizzando polietilene espanso a cellule chiuse (tipo spugna). La pellicola che ricopre la spugna è fatta sempre in polietilene. La ricopertura segue la normativa L 10/91 secondo la normativa antincendio CL 1. La guaina è di colore osso cardinale mentre la spugna ha uno spessore di 6 mm equamente arrotolato intorno al tubo è di colore grigio. Sulla guaina sono riportate una serie di informazioni: data di confezionamento, misura del tubo, materia prima utilizzata, normative metratura per facilitarne l'utilizzo.

DIMENSIONAL TEST

Measurement of the thickness of the layers:

Thicknesses and tolerances of layers are in accordance with the same regulation as S serie, point 7 UNI 10954/1 prospects 2/3.

The S serie belonging to each measure is the following (16 x 2 = S26) (20 x 2 - 26 x 3 - 32 x 3 correspond to S serie 34,5 / 42.8).

Determination of the resistance to the hydrostatic pressure following UNI 10954-1:2004 and mechanical features.

The test has been driven following the rule UNI EN 921:1995 in following conditions:

Set hydrostatic pressure	20,5 bar (norm testing up to 19,73)
Declared class of belonging	2
Set test temperature	95°C
Nature of the testing environment	Water
Plugs used	Type A
Free length of the tube	200 mm.
Testing time	1008 h (norm testing 1000 h)
Testing position	Vertical

The uncertainty of measure is expressed as derivation from std: pressure ±0,1 bar, temperature ±1,4°C.

The results obtained are the followings:

Chemical and physical features

The inner layer degree of reticulation of the control test carried out on the samples accordingly to rule UNI EN 579 Art 495 16 = 66,4%_ Art 495 20 = 65,8%_ Art 495 26 = 65,7% _ Art 495 32 = 65,6%.

The outer layer degree of reticulation of the control test carried out on the samples accordingly to rule UNI EN 579 Art 495 16 =1,5%_ Art 495 20 = 1,3% _ Art 495 26 = 1% _ Art 495 32 =1,4%.

Accordingly to what scheduled from UNI 10954 1 prospectus 5:

- 1) the material used for the internal layer is PE-Xb while the external layer is in HDPE
- 2) the intermediate layer of the multilayer tube is in aluminium, type A, point 5,3 rule UNI 10954 / 1
- 3) no breakaway has happened after the Bending test
- 4) the layers did not separate after the Countersinking Test
- 5) the bonding of the plastic material to the intermediate layer determined through the separation of the same, gave the following result:

The multilayer tube Art. 495 R (R stands for covered) is different from the multilayer tube only for the cover obtained by using closed cells expanded polyethylene (sponge type). The tape covering the sponge is also made by polyethylene. The covering follows the regulation L 10/91 in accordance with the fire regulation CL 1. The cover is red colour while the sponge has a mm. 6 thickness equally wrapped around the tube and is grey colour. Some info are printed on the covering: packing date, tube length, raw material, measurement regulation to help the use.

RUBINETTERIA
TAPS

FLESSIBILI
FLEXIBLE HOSES

MINUTERIA
MINUTERY

VALVOLE
VALVES

RACCORDERIA
FITTINGS

ACCESSORI
ACCESSORIES

COMPONENTI PLASTICI
PLASTIC COMPONENTS

ACCESSORI PER RADIATORI - RADIATOR ACCESSORIES



Tappo zincato per radiatori in ghisa e acciaio, destro e sinistro, tappo cieco.
Zinc plated plug for radiators in cast iron and stainless steel, right and left, no hole plug.

540DX10	1"	540SX10	1"
540DX114	1"1/4	540SX114	1"1/4
540DX11412	1"1/4 x 1/2	540SX11412	1"1/4 x 1/2



Tappo verniciato per radiatori in alluminio, destro e sinistro, tappo cieco.
Plug for radiators in aluminium, painted white, right and left, no hole plug.

541DX10	1"	541SX10	1"
541DX1038	1" x 3/8	541SX1038	1" x 3/8
541DX1012	1" x 1/2	541SX1012	1" x 1/2
541DX114	1" x 1/4	541SX114	1" x 1/4



Valvolina sfogo aria manuale, per radiatori, con guarnizione in P.T.F.E. cromata.
C.P. drain plug for radiators with P.T.F.E. seal ring.

43014	1/4
43038	3/8
43012	1/2



Valvolina sfogo aria manuale, per radiatori, cromata a scarico orientabile.
C.P. drain plug for radiators, adjustable.

43138	3/8
43112	1/2



Tappo in ottone cromato per radiatori.
C.P. brass plug for radiators.

431TA12	1/2
----------------	-----



Kit per radiatori in alluminio, composto da: 2 riduzioni destre e 2 sinistre, tutte verniciate, da 1" x 3/8 o 1" x 1/2, 1 tappo cieco in ottone con o-ring da 3/8 o 1/2, 4 guarnizioni esente amianto, spessore 1,5 mm e Ø 42 mm, 1 valvola di sfogo aria da 3/8 o 1/2, il tutto in skinpack Remer.

Kit for aluminum radiators, composed by: 2 right and 2 left reductions, all painted, size 1" x 3/8 or 1" x 1/2, 1 no hole plug in brass with 3/8 or 1/2 oring, 4 asbestos free washers thickness 1,5 mm and Ø 42 mm, 1 drain plug in 3/8 or 1/2 size, all packed in a Remer skinpack.

545	1" x 1/2"
54538	1" x 3/8"



Kit per radiatori in ghisa, composto da: 2 riduzioni destre e 2 sinistre, zincate, disponibili da: 1" x 3/8, 1" x 1/2, 1"1/4 x 3/8, 1"1/4 x 1/2, 1 tappo cieco in ottone con o-ring da 3/8 o 1/2, 4 guarnizioni esente amianto, spessore 1,5 mm e Ø 42, 1 valvola di sfogo aria da 3/8 o 1/2, il tutto in skinpack Remer.

Kit for iron radiators, composed by: 2 right and 2 left reductions, all painted, available is sizes: 1" x 3/8, 1" x 1/2, 1"1/4 x 3/8, 1"1/4 x 1/2, 1 no hole plug in brass with 3/8 or 1/2 oring, 4 asbestos free washers thickness 1,5 mm and Ø 42 mm, 1 drain plug in 3/8 or 1/2 size, all packed in a Remer skinpack.

546	1" x 1/2"
------------	-----------



Kit per radiatori in alluminio, composto da: 2 riduzioni destre e 2 sinistre, tutte verniciate, da 1" x 3/8 o 1" x 1/2, 1 tappo cieco in ottone con o-ring da 3/8 o 1/2, 4 guarnizioni esente amianto, spessore 1,5 mm e Ø 42, 1 valvola di sfogo aria da 3/8 o 1/2, coppia mensole piatte complete con tassello Ø mm 12, lunghezza mm 170, il tutto in skinpack Remer.

Kit for aluminum radiators, composed by: 2 right and 2 left reductions, all painted, size 1" x 3/8 or 1" x 1/2, 1 no hole plug in brass with 3/8 or 1/2 oring, 4 asbestos free washers thickness 1,5 mm and Ø 42 mm, 1 drain plug in 3/8 or 1/2 size, two painted and flat anchor brackets, with nut Ø mm 12, length mm 170, all packed in a Remer skinpack.

548	1" x 1/2"
------------	-----------



Chiave in plastica dura, per tappi verniciati.
Key for art. 541, in strong plastic.

544	
------------	--



Mensola zincata per radiatori in ghisa e acciaio spessore 15/10, lunghezza mm 220.
Wall bracket for holding radiators in iron and steel, thickness 15/10, length mm 220.

63522	Ø mm 220
--------------	----------



Coppia mensole Ø 12 per radiatori in ghisa e acciaio a 4/5 colonne, con tasselli, lunghezza mm 205.
Two galvanised anchor brackets Ø 12 for holding radiators in iron and steel with 4/5 columns, with nuts, length mm 205.

630205



Coppia mensole Ø 7 bianche verniciate e di forma piatta, per radiatori in alluminio, con tasselli, lunghezza mm 170.
Two galvanised anchor brackets Ø 7 flat shaped and painted white for holding radiators in aluminium, with nuts, length mm 170.

633

RUBINETTERIA
TAPS

FLESSIBILI
FLEXIBLE HOSES

MINUTERIA
MINUTERY

VALVOLE
VALVES

RACCORDERIA
FITTINGS

ACCESSORI
ACCESSORIES

COMPONENTI PLASTICI
PLASTIC COMPONENTS

ACCESSORI PER TUBI - ACCESSORIES FOR PIPES



Collari pesanti zincati con dado saldato e tassello, per tubazioni.
Wall collars in galvanized steel welded and plastic nut, for pipes.

64238	3/8
64212	1/2
64234	3/4
64210	1"
642114	1 1/4
642112	1 1/2
64220	2"
642212	2 1/2
64230	3"
64240	4"



Collari pesanti in acciaio zincato con dado saldato, con gomma EPDM isolante e tassello, per tubazioni.
Wall collars in galvanized steel welded, with insulating EPDM rubber, with plastic nut, for pipes.

64338	3/8
64312	1/2
64334	3/4
64310	1"
643114	1 1/4
643112	1 1/2
64320	2"
643212	2 1/2
64330	3"
64340	4"



Fascetta stringitubo in acciaio.
Steel hose clip.

6451018	10 / 18
6451424	14 / 24
6451729	17 / 29
6452537	25 / 37
6452545	25 / 45
6453353	33 / 53
6454060	40 / 60
6454868	48 / 68
6457898	78 / 98



Sgombratubi in filo d'acciaio a spirale Ø mm. 8.
Drain cleaner in 8 mm Ø stainless steel spiral.

640150	150 cm
640250	250 cm
640350	350 cm
640500	500 cm
640700	700 cm
6401000	1000 cm
6401250	1250 cm
6401500	1500 cm

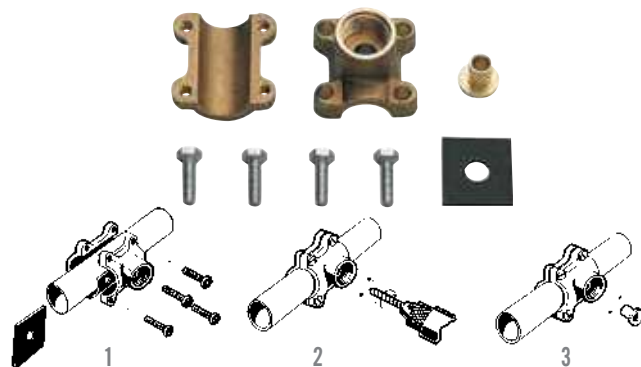

Presapresa per tubi, misure da 1/2" a 2".
Fast punch for water outlet, size from 1/2" to 2".

	Ø A	Ø B	G"
Tubo Pipe	Foro per Acqua Water Hole	Diametro Punta Drill Diameter	Filetto Thread
1/2	7,5 mm	Ø 10 mm	1/2
3/4	10,5 mm	Ø 13,5 mm	1/2
1"	13 mm	Ø 16 mm	3/4
1 1/4	14 mm	Ø 17,5 mm	3/4
1 1/2	14 mm	Ø 17,5 mm	3/4
2"	30 mm	Ø 35 mm	1 1/2

64412	1/2 x 45
64434	3/4 x 45
64410	1" x 45
644114	1 1/4 x 71
644112	1 1/2 x 77



ACCESSORI ACCESSORIES



ACCESSORI - ACCESSORIES

RUBINETTERIA
TAPS

FLESSIBILI
FLEXIBLE HOSES

MINUTERIA
MINUTERY

VALVOLE
VALVES

RACCORDERIA
FITTINGS

ACCESSORI
ACCESSORIES

COMPONENTI PLASTICI
PLASTIC COMPONENTS



RUBINETTI - FAUCETS



Rubinetto prolungato con comando a gomito, 1/2.
Wall mounted long tap, 1/2, with long lever.
61



Rubinetto a snodo con comando a gomito, 1/2, con canna inferiore.
Wall mounted hose-holder tap, 1/2, with long lever and S inferior spout.
63



Gruppo lavello con comando a gomito e canna inferiore.
Wall mounted mixer, with long levers and S inferior spout.
64



Gruppo lavello tipo a ponte con comando a gomito e canna Ø 18 mm.
Sink mixer bridge type, with long lever and spout Ø 18 mm.
14LL



Rubinetto collo cigno con comando a gomito, 1/2.
Wash basin pillar tap, 1/2, with long lever.
65



Leva in ottone cromato per articoli 61, 63, 64, 65, 14LL.
Lever for art. 61, 63, 64, 65, 14LL.
61LE



Leva lunga per miscelatori con cartuccia Ø 40.
Spare long lever for single lever mixers with Ø 40 cartridge.
MA14



Vitone da 1/2 per articoli 61, 63, 64, 65, 14LL.
Head valve 1/2 for articles 61, 63, 64, 65, 14LL.
61VI



Rubinetto a pedale ad incasso in ottone cromato.
Built in tap foot operated, in c.p. brass.
66



Rubinetto-miscelatore pedaliera universale. Può essere installato sia a parete che a pavimento.
Treadle mixer with universal pedal control. It can be installed both on the wall and on the floor.
66MP



Bocca a snodo per lavello.
Movable spout for washbasin.
67



Bocca alta minimale.
Minimal high spout.
67N



Bocca alta quadrata.
Squared high spout.
67Q



Rubinetto a pulsante a zampillo parabolico per refrigeratore o depuratore. Regolazione del getto sotto il pulsante.
Parabolic jet button tap for refrigerator or purifier. Water flow control under the button.
69

CARTUCCE - CARTRIDGES



Cartuccia progressiva Ø 35, con distributori, con chiusura del flusso e uscita dell'acqua verso il basso.
Ceramic cartridge Ø 35, with distributors, with flow shut-off and water outlet towards the low.
P50



Cartuccia progressiva Ø 35, senza distributori, con chiusura del flusso e uscita dell'acqua verso il basso.
Ceramic cartridge Ø 35, without distributors, with flow shut-off and water outlet towards the low.
P52



Cartuccia a dischi ceramici Ø 25 mm, tipo piatto.
Ceramic cartridge Ø 25 mm, flat bottom type
V50C



Cartuccia a dischi ceramici Ø 25, con uscita dell'acqua direttamente dalla parte alta dell'involucro a cilindro senza quindi essere riconvolgiato verso il fondo della cartuccia.
Ceramic discs cartridge Ø 25, with water outlet directly from the top part of the cylindrical shell without being joined towards the bottom of the cartridge.
V50A



Cartuccia a dischi ceramici Ø mm 35, movimento a "joystick", tipo piatto.
Ceramic cartridge Ø 35 mm, "joystick" movement, flat bottom type

J50



Cartuccia termostatica coassiale serie MINIMAL THERMO e QUBIKA THERMO.
Thermostatic coaxial cartridge serie MINIMAL THERMO and QUBIKA THERMO.

E50C



Cartuccia termostatica con rotazione manopola a 330° angolari, blocco di sicurezza a 38°C, campo di lavoro da 5°C a 80°C, campo di pressione da 1 a 10 bar, filtro inox e sistema di sicurezza con blocco dell'erogazione in caso di mancanza di una delle due acque, realizzato con materiali termoplastici ad elevata robustezza.
Thermostatic cartridge with 330° angular handle rotation, 38° safety lock, working field from 5°C to 80°C, pressure field from 1 to 10 bar, stainless steel filter and safety system with the outlet lock in case there is one water lock, high performance thermoplastic materials.

E50P



CLICK SYSTEM

Cartuccia ad apertura forzata Ø mm 40 a dischi ceramici per vasca, lavabo, bidet (tipo con distributori) permette un notevole risparmio idrico.
Forced opening ceramic cartridge Ø 40 mm for bath, wash basin, bidet (type with distributors) permit a remarkable saving of water.

S50AF



CLICK SYSTEM

Cartuccia ad apertura forzata Ø mm 40 a dischi ceramici per lavello, doccia (tipo piatto) permette un notevole risparmio idrico.
Forced opening ceramic cartridge Ø 40 mm for sink, shower (flat bottom type) permit a remarkable saving of water.

S52AF



CLICK SYSTEM

Cartuccia ad apertura forzata Ø 35 mm a dischi ceramici per lavello, doccia (tipo piatto) permette un notevole risparmio idrico.
Forced opening ceramic cartridge Ø 35 mm for sink, shower (flat bottom type) permit a remarkable saving of water.

R52AF



CLICK SYSTEM

Cartuccia ad apertura forzata Ø 35 mm a dischi ceramici per vasca, lavabo, bidet (tipo con distributori) permette un notevole risparmio idrico.
Forced opening ceramic cartridge Ø 35 mm for bath, wash basin, bidet (type with distributors) permit a remarkable saving of water.

R50AF

CARTUCCE IN BLISTER - CARTRIDGES IN BLISTER



Cartuccia Ø mm 40 a dischi in ceramica per vasca, lavabo, bidet (tipo con distributori).
Ceramic cartridge Ø 40 mm for bath, wash basin, bidet (type with distributor).

S50Y



Cartuccia Ø mm 40 a dischi in ceramica per lavello, doccia (tipo piatto).
Ceramic cartridge Ø 40 mm for sink and shower (flat bottom type).

S52Y



Cartuccia Ø mm 35 a dischi in ceramica per vasca, lavabo, bidet (tipo con distributori).
Ceramic cartridge Ø 35 mm for bath, wash basin, bidet (type with distributor).

R50Y



Cartuccia Ø mm 35 a dischi in ceramica per lavello, doccia (tipo piatto).
Ceramic cartridge Ø 35 mm for sink and shower (flat bottom type).

R52Y



Cartuccia Ø mm 35 a dischi ceramica per lavello, doccia, vasca, bidet (tipo piatto).
Ceramic cartridge Ø 35 mm for sink, shower, bath, bidet (flat bottom type).

W50Y

RUBINETTERIA
TAPS

FLESSIBILI
FLEXIBLE HOSES

MINUTERIA
MINUTERY

VALVOLE
VALVES

RACCORDERIA
FITTINGS

ACCESSORI
ACCESSORIES

COMPONENTI PLASTICI
PLASTIC COMPONENTS

DEVIATORI - DIVERTERS



Deviatore a tre vie (una entrata e tre uscite) su piastra, serie Qubika.
Three ways diverter (1 inlet and 3 outlets) on flange, Qubika serie.

Q93DEV3



Deviatore a tre vie e sette posizioni (una entrata, tre uscite e sette posizioni con cui selezionare uscite singole o miscelate tra loro) su piastra, serie Qubika.

Three ways diverter with seven positions (1 inlet and 3 outlets and seven positions to select single or mixed outlets) on flange, Qubika serie.

Q93DEV7



Deviatore a tre vie (una entrata e tre uscite) su piastra, serie Minimal.
Three ways diverter (1 inlet and 3 outlets) on flange, Minimal serie.

N93DEV3



Deviatore a tre vie e sette posizioni (una entrata, tre uscite e sette posizioni con cui selezionare uscite singole o miscelate tra loro) su piastra, serie Minimal.

Three ways diverter with seven positions (1 inlet and 3 outlets and seven positions to select single or mixed outlets) on flange, Minimal serie.

N93DEV7

PROLUNGHE - EXTENSIONS



Prolunga per corpo monocomando doccia incasso con deviatore per cartuccia Ø 40 mm.

Extension for built-in shower mixer body with diverter for cartridge Ø 40 mm.

K09PROL



Prolunga per corpo monocomando doccia incasso con deviatore per cartuccia Ø 35 mm.

Extension for built-in shower mixer body with diverter for cartridge Ø 35 mm.

N09PROL



Prolunga per corpo monocomando doccia incasso con cartuccia Ø 40 mm.
Extension for built-in shower mixer body with cartridge Ø 40 mm.

S52PROL



Prolunga per corpo monocomando doccia incasso con cartuccia Ø 35 mm.
Extension for built-in shower mixer body with cartridge Ø 35 mm.

R52PROL

DEVIATORI AUTOMATICI - AUTOMATIC DIVERTERS



Vite fissa maniglia.
Screw for fixing handle.

78



Morsetto con vite per scarico automatico.
Joint with screw for pop-up waste.

80SN



Deviatore in ottone automatico con molla e fermo per basse pressioni.
Automatic brass diverter with spring and lock for low pressure.

DEV00



Deviatore in ottone automatico con molla e fermo, con prolunga 8 mm.
Automatic brass diverter with spring and lock, mm 8 extended in 1/2 side.

DEV08



Deviatore in ottone automatico con molla e fermo, con prolunga 13 mm.
Automatic brass diverter with spring and lock, mm 13 extended in 1/2 side.

DEV13

VITONI - HEADVALVES



Vitone universale per rubinetti, che permette di ottenere 102 combinazioni di misure e lunghezze. Confezione skin-pack.
Universal headvalve for taps, allow to create 102 different combinations of lengths and sizes. Packed in a safe skin-pack.

75



Vitone con filetto 19/19, per rubinetti incasso.
19/19 Head valve thread, for built-in stop cocks.

7719



Vitone da 1/2 per gruppo vasca, lavello, batteria lavabo, rubinetto bidet e incasso per art. 53, 55.
Head valve 1/2" for bath, sink, wash basin, bidet and built-in stop cock for art. 53, 55.

74



Come 74, tipo leggero.
As 74, light type.

74E



Vitone da 1/2 con filetto per coprivitone M24x1.
Head valve 1/2 with thread M24x1 for head valve cover.

74F



Vitone filetto 18/19 per art. 221, 223, 224, 250, 252 e altri.
18/19 Head valve thread for art. 221, 223, 224, 250, 252 and others.

7718



Vitone con filetto 3/8, per rubinetti.
3/8 Head valve thread, for taps.

7738



Vitone 180° a dischi ceramici, broccia Ø mm 8, 20 denti, destro.
Head valve 180° ceramic discs, broach Ø 8 mm, 20 teeth, right.

76DX180



Vitone 90° a dischi ceramici, broccia Ø 8 mm, 24 denti, destro.
Head valve 90° ceramic discs, broach Ø 8 mm, 24 teeth, right.

76DX24



Vitone 90° a dischi ceramici, broccia Ø 8 mm, 20 denti, destro.
Head valve 90° ceramic discs, broach Ø 8 mm, 20 teeth, right.

76DX



Vitone 180° a dischi ceramici, broccia Ø mm 8, 20 denti, sinistro.
Head valve 180° ceramic discs, broach Ø 8 mm, 20 teeth, left.

76SX180



Vitone 90° a dischi ceramici, broccia Ø 8 mm, 24 denti, sinistro.
Head valve 90° ceramic discs, broach Ø 8 mm, 24 teeth, left.

76SX24



Vitone 90° a dischi ceramici, broccia Ø 8 mm, 20 denti, sinistro.
Head valve 90° ceramic discs, broach Ø 8 mm, 20 teeth, left.

76SX

RUBINETTERIA
TAPS

FLESSIBILI
FLEXIBLE HOSES

MINUTERIA
MINUTERY

VALVOLE
VALVES

RACCORDERIA
FITTINGS

ACCESSORI
ACCESSORIES

COMPONENTI PLASTICI
PLASTIC COMPONENTS



AERATORI: LINEA RISPARMIO IDRICO-ENERGICO E ANTIVANDALICO AERATOR: WATER ENERGY SAVING LINE AND ANTI-VANDALISM



Kit antivandalico e anticalcare composto da aeratore speciale per miscelatori lavabo e bidet M24 e chiave di montaggio, manutenzione e pulizia settimanale, ad alta tecnologia, brevettata. Anti-vandalism and anti-limestone kit, composed by special aerator for wash basin and bidet mixers M24 and assembly, caring and weekly cleaning key, high technology and patented.

83AVC



Set risparmio idrico totale composto da raccordo doccia 1/2" in ottone cromato a portata limitata, aeratore lavabo e bidet M24 a portata limitata e chiave di montaggio manutenzione e pulizia settimanale, ad alta tecnologia, brevettata. Il kit è disponibile in varianti da 6 litri al minuto (cod 83 SET L6) o 8 litri al minuto (cod 83 SET L8).

Total water saving set, composed by 1/2" shower connection with reduced flow in c.p. brass, wash basin and bidet aerator with reduced flow and assembling, caring and weekly cleaning key, high technology, patented. This set is available with outlet flow of 6 liters by minute (cod 83 SET L6) or 8 liters by minute (cod 83 SET L8).

83SETL6

83SETL8



Kit come 83 AVC, più risparmio idrico, che include anche limitatore di portata da 6 litri al minuto, art 83AVC L6, o limitatore di portata da 8 litri al minuto, art 83 AVC L8.

Kit same as 83 AVC, plus water saving, that also includes one reduction of water consumption at 6 liters by minute, art 83 AVC L6, or one reduction of water consumption at 8 liters by minute, art 83 AVC L8.

83AVCL6

83AVCL8



Aeratore lavabo e bidet M24, per risparmio idrico con limitatore di portata da 6 litri al minuto (art. 83 L6) o da 8 litri al minuto (art. 83 L8).

Aerator for wash basin and bidet mixers, M24, water saving, with reduction of consumption and excellent flow at 6 litres by minute (art. 83 L6) or 8 liters by minute (art. 83 L8).

83L6

83L8



Guarnizione da 1/2" con filtro retinato anti-impurità. 1/2" washer with net filter, anti-impurity.

662F112



Raccordo doccia 1/2" a risparmio idrico con limitatore di portata da 6 litri al minuto (art 309 L6) o 8 litri al minuto (art 309 L8).

C.p. brass connection, water saving program with flow reduction at 6 liters by minute (art 309 L6) or 8 liters by minute (art 309 L8).

309RL6

309RL8



KIT PULIZIA AERATORE CLEANING KIT WITH AERATOR



Set completo di 3 aeratori anticalcare M24 ad alta tecnologia + 1 chiave per la pulizia settimanale, brevettati e di lunghissima durata, il tutto in ottone cromato e materiale plastico innovativo a forte resistenza, confezionato in un tubo contenitore rigido e trasparente adatto per essere appeso. La chiave è stata studiata per pulire il calcare dall'aeratore in un solo semplice movimento.

Set complete of 3 anti-limestone M24 aerators of high technology + 1 weekly cleaning key, patented and extremely long lasting, all in c.p. brass and innovative plastic material very resistant, packed in a holding hard and transparent tube, suitable to be hung. The key has been studied to clean the aerator in one simple, easy movement.

83SET01



Set completo di 2 aeratori anticalcare M24 ad alta tecnologia ed e 1 aeratore anticalcare F22 + 1 chiave per la pulizia settimanale, brevettati e di lunghissima durata, il tutto in ottone cromato e materiale plastico innovativo a forte resistenza, confezionato in un tubo contenitore rigido e trasparente adatto per essere appeso. La chiave è stata studiata per pulire il calcare dall'aeratore in un solo semplice movimento.

Set complete of 2 anti-limestone M24 aerators of high technology and 1 anti-limestone F22 aerator + 1 weekly cleaning key, patented and extremely long lasting, all in c.p. brass and innovative plastic material very resistant, packed in a holding hard and transparent tube, suitable to be hung. The key has been studied to clean the aerator in one simple, easy movement.

83SET02



Set completo di 1 aeratore F22 anticalcare ad alta tecnologia + 1 chiave di pulizia settimanale, brevettati e di lunghissima durata, il tutto in ottone cromato e materiale plastico innovativo a forte resistenza. L'aeratore e la chiave sono stati studiati per pulire il calcare dall'aeratore in un solo semplice movimento.

Set complete of 1 anti-limestone F22 aerator of high technology + 1 weekly cleaning key, Patented and extremely long lasting, all in c.p. brass and innovative plastic material very resistant. The aerator and the key has been studied to clean the aerator in one simple, easy movement.

81AC



Set completo di 1 aeratore M24 anticalcare ad alta tecnologia + 1 chiave di pulizia settimanale, brevettati e di lunghissima durata, il tutto in ottone cromato e materiale plastico innovativo a forte resistenza. L'aeratore e la chiave sono stati studiati per pulire il calcare dall'aeratore in un solo semplice movimento.

Set complete of 1 anti-limestone M24 aerator of high technology + 1 weekly cleaning key, Patented and extremely long lasting, all in c.p. brass and innovative plastic material very resistant. The aerator and the key has been studied to clean the aerator in one simple, easy movement.

83AC

RIDUZIONI - REDUCTION



Riduzione 1/2MxM22. Consente di collegare qualsiasi attacco da 1/2F", esempio tutti i flessibili doccia, con un aeratore standard lavabo/lavello F22, vedi ns articolo 81A (al posto di una doccetta o di uno shut off).

Reduction 1/2MxM22. Allows to connect any 1/2F" connection, for example all the shower flexibles, with a standard aerator basin/sink F22, see our art. 81A (instead of the classic handshower or shut-off).

81RD12



Riduzione 1/2MxF22. Consente di collegare al lavabo/lavello F22 un qualsiasi componente con attacco 1/2F.

1/2MxF22 reduction. Connecting any component with 1/2F connection to the washbasin/sink F22.

81RD12M22F



Riduzione 1/2FxM22. Consente di collegare al lavabo/lavello F22 un qualsiasi componente con attacco 1/2M.

1/2FxM22 reduction. Connecting any component with 1/2M connection to the washbasin/sink F22.

83RD12F22F



Riduzione 1/2MxF24. Consente di collegare qualsiasi attacco da 1/2F", esempio tutti i flessibili doccia, con un aeratore standard lavabo M24, vedi ns articolo 83A (al posto di una doccetta o di uno shut off).

Reduction 1/2MxF24. Allows to connect any 1/2F" connection, for example all the shower flexibles, with a standard aerator basin M24, see our art. 83A (instead of the classic handshower or shut-off).

83RD12



Riduzione 1/2MxM24. Consente di collegare al lavabo/lavello M24 un qualsiasi componente con attacco 1/2F.

1/2MxM24 reduction. Connecting any component with 1/2F connection to the washbasin/sink M24.

83RD12M24M



Riduzione 1/2FxM24. Consente di collegare al lavabo/lavello M24 un qualsiasi componente con attacco 1/2M.

1/2FxM24 reduction. Connecting any component with 1/2M connection to the washbasin/sink M24.

83RD12F24M



Aeroflux a due getti, con doccetta a snodo, filetto F22 con riduzione M24.

Double spray aerator, with balljoint shower, thread F22 with reduction M24.

82



Aeroflux a due getti, con ghiera e filetto F22, lunghezza 15 cm.

Double spray aerator, with nut and thread F22, length 15 cm.

82LGH



Aeroflux a due getti, con doccetta a snodo, con attacco universale.

Double spray aerator, with balljoint shower, with standard connection.

82UN

RUBINETTERIA
TAPS

FLESSIBILI
FLEXIBLE HOSES

MINUTERIA
MINUTERY

VALVOLE
VALVES

RACCORDERIA
FITTINGS

ACCESSORI
ACCESSORIES

COMPONENTI PLASTICI
PLASTIC COMPONENTS

AERATORI - AERATOR



Aeratore anticalcare ad alta tecnologia F22, brevettato e di lunghissima durata, scocca in ottone ed interno in materiale plastico innovativo a forte resistenza.
High technology anti-limestone aerator F22, patented and long-lasting, shell in c.p. brass, internal in innovative plastic material very resistant.

81A



Aeratore anticalcare ad alta tecnologia M24, brevettato e di lunghissima durata, scocca in ottone ed interno in materiale plastico innovativo a forte resistenza.
High technology anti-limestone aerator M24, patented and long-lasting, shell in c.p. brass, internal in innovative plastic material very resistant.

83A



Chiave brevettata per la pulizia settimanale degli aeratori ad alta tecnologia art 81 A e art 83 A.
Patented key for the weekly cleaning of the high technology aerators art 81 A and 83 A.

83C



Aeratore classico con retine in inox, per gruppo lavello F22.
Classic aerator with inox nets, for sink spout F22.

81



Aeratore classico con retine in inox, per lavabo, lavello e bidet M24.
Classic aerator with inox nets, for basin, bidet and sink, M24.

83



Aeratore per gruppo vasca, M28.
Aerator for bath mixer, M28.

84A



Aeratore F16.
F16 aerator.

83F16



Snodo attacco F22 con ghiera M22.
Joint F22 and nut M22.

81SN



Snodo attacco M22 con ghiera M24.
Joint M22 and nut M24.

83SN



Aeratore M18.
M18 aerator.

83N41



Aeratore con snodo per monoforo bidet, M24.
Balljoint aerator for one-hole bidet, M24.

85



Aeratore Neoperl autopulente M24X1 con erogatore in silicone morbido anticalcare per una pulizia manuale semplificata.
Neoperl aerator selfcleaning M24X1 with silicon antilimestone bottom, for soft simplified handcleaning.

83NESI



Aeratore Neoperl effetto a scomparsa, con tecnologia in silicone autopulente per una pulizia veloce dal calcare, con filetto M24X1 che puo' essere sostituito senza difficoltà a tutte le rubinetterie con filettatura per aeratore M24X1. Molto indicato per modelli di design quali Qubika, Minimal, SQ.

Neoperl aerator with built-in effect, with silicon anti-limestone technology for an easier cleaning, M24X1 thread, can be easily substituted to all the standard mixers with M24X1 aerators.
Very indicated for design models like Qubika, Minimal, SQ.

83NE



Aeratore Neoperl M24X1 con getto direzionabile tramite terminale basculante, permette con il semplice tocco della parte inferiore dell'aeratore di dirigere il flusso della direzione desiderata.
Neoperl aerator M24X1 with movable aerator bottom that, with the simple touch, permits to move the flow to the preferred direction.

83NEBA



Aeratore Neoperl M24 coin slot. Installazione e rimozione dell'aeratore utilizzando una moneta inserita nell'apposita fessura.
Neoperl aerator M24 coin slot. Installation and removal of the aerator by using a coin placed in the slot.

83EU

ECCENTRICI E DISTANZIATORI - ECCENTRICS & CONNECTIONS



Eccentrico per gruppi, 1/2 x 3/4, con rosone in ottone cromato.
Eccentric unions for mixers, 1/2 x 3/4, with C.P. brass flange.

89



Eccentrico per gruppi, 1/2x3/4, tipo Lusso, con rosone in ottone cromato.
Eccentric unions for mixers, 1/2 x 3/4, with C.P. brass flange.

89L



Eccentrico per gruppi, 1/2 x 3/4, con rosone minimale in ottone cromato.
Eccentric unions for mixers, 1/2 x 3/4, with minimal C.P. brass flange.

89N



Distanziatore per gruppi, 1/2x3/4, lunghezza cm.4, 6, 8.
C.P. brass S-connection for mixers, 1/2x3/4, length 4, 6, 8 cm.

9012344 cm 4

9012346 cm 6

9012348 cm 8

RUBINETTERIA
TAPS

FLESSIBILI
FLEXIBLE HOSES

MINUTERIA
MINUTERY

VALVOLE
VALVES

RACCORDERIA
FITTINGS

ACCESSORI
ACCESSORIES

COMPONENTI PLASTICI
PLASTIC COMPONENTS

COLONNE PER BORDO VASCA - VERTICAL CONNECTION FOR BATH MIXER



Coppia colonne vasca in ottone cromato, serie Liberty, 3/4M x 3/4M.
Couple c.p. brass vertical connections for bath mixer, serie Liberty, 3/4M x 3/4M.

8801LI



Coppia colonne vasca in ottone cromato, serie Liberty, con supporto doccia, 3/4M x 3/4M.
Couple c.p. brass vertical connections for bath mixer, serie Liberty, with hand shower holder 3/4M x 3/4M.

8801LIS

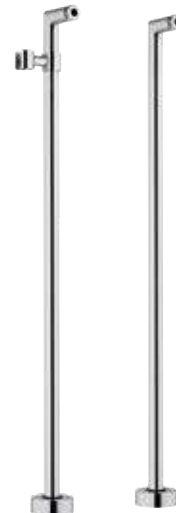

Coppia colonne vasca in ottone cromato, serie Minimal, con supporto doccia, 3/4M x 3/4M.
Couple c.p. brass vertical connections for bath mixer, serie Minimal, with hand shower holder 3/4M x 3/4M.

88N02



Coppia colonnette bordo vasca in ottone cromato, serie UK, 3/4Mx3/4M.
Couple c.p. brass vertical connections for bath mixer, serie Minimal, with hand shower holder 3/4M x 3/4M.

88UK



Coppia colonnette bordo vasca in ottone cromato, serie Liberty, 3/4M x 3/4M.
Couple c.p. brass vertical connections for bath mixer, serie Liberty, 3/4M x 3/4M.

88LI



Colonnetta per bordo vasca in ottone cromato, 1/2M x 3/4M.
C.P. brass vertical connection for bath mixer, 1/2M x 3/4M.

88

BOCCHIE - SPOUTS



22,5 cm

Canna livello inferiore a "S", tipo universale, con aeratore.
Lower "S" sink spout, universal type, with aerator.

86



20 cm

Canna livello inferiore a "S", cm 20, con aeratore.
Lower "S" sink spout, cm 20, with aerator.

86N



40 cm

Canna livello inferiore a "S", cm 40, con aeratore.
Lower "S" sink spout, cm 40, with aerator.

86N40

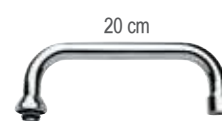

20 cm

Canna livello superiore a "U", cm 20, con aeratore.
Upper "U" sink spout, cm 20, with aerator.

86U



Canna a "J" per monoforo lavello, con aeratore.
"J" spout for one-hole sink, with aerator.

87N



Canna a "J" per monoforo lavello, tipo universale, con aeratore.
"J" spout for one-hole sink, universal type, with aerator.

87



Canna a biscotto a "C" con calotta da 3/4, con aeratore.
"C" spout with nut 3/4, with aerator.

92C



Canna a biscotto a "C" con calotta da 3/4, con aeratore, tipo corto.
"C" spout with nut 3/4, with aerator, short type.

92CC



Canna a "U" Ø 22, con aeratore.
"U" spout Ø 22, with aerator.

92U



30 cm

Canna fusa lunga cm 30 con deviatore, con calotta da 3/4 ed aeratore.
Casted cm 30 long spout with diverter, with 3/4 nut, with aerator.

93



16 cm

Canna a biscotto diritta, calotta da 3/4, lunghezza cm.16, con aeratore.
Straight spout with 3/4 nut, 16 cm long, with aerator.

9216



20 cm

Canna a biscotto diritta, calotta da 3/4, lunghezza cm.20, con aeratore.
Straight spout with 3/4 nut, 20 cm long, with aerator.

9220



30 cm

Canna a biscotto diritta, calotta da 3/4, lunghezza cm. 30, con aeratore.
Straight spout with 3/4 nut, 30 cm long, with aerator.

9230



40 cm

Canna a biscotto diritta, calotta da 3/4, lunghezza cm.40, con aeratore.
Straight spout with 3/4 nut, 40 cm long, with aerator.

9240



50 cm

Canna a biscotto diritta, calotta da 3/4, lunghezza cm. 50, con aeratore.
Straight spout with 3/4 nut, 50 cm long, with aerator.

9250



16 cm

Canna a biscotto a "S", calotta da 3/4, lunghezza cm.16, con aeratore.
"S" spout with 3/4 nut, 16 cm long, with aerator.

92S16



20 cm

Canna a biscotto a "S", calotta da 3/4, lunghezza cm.20, con aeratore.
"S" spout with 3/4 nut, 20 cm long, with aerator.

92S20



30 cm

Canna a biscotto a "S", calotta da 3/4, lunghezza cm.30, con aeratore.
"S" spout with 3/4 nut, 30 cm long, with aerator.

92S30

SUPPORTI DOCCIA - SUPPORTS FOR HANDSHOWERS



Supporto per doccia estraibile per bordo lavello e bordo vasca, modello a base tonda.
Support for extensible handshower for deck bath and deck sink, round base model.

32507



Supporto dritto per doccia estraibile per bordo lavello e bordo vasca, modello a base quadrata.
Straight support for extensible handshower for deck bath and deck sink, squared base model.

325S07

RUBINETTERIA
TAPS

FLESSIBILI
FLEXIBLE HOSES

MINUTERIA
MINUTERY

VALVOLE
VALVES

RACCORDERIA
FITTINGS

ACCESSORI
ACCESSORIES

COMPONENTI PLASTICI
PLASTIC COMPONENTS



Tappo scarico automatico in ottone per piletta 1" e per piletta 1"1/4.
C.p. brass plug for pop-up waste for drain 1" and for drain 1"1/4.

95TA10 1"

95TA114 1" 1/4



Tappo grande in ottone cromato per scarico automatico con piletta da 1"1/4.
Big plug in c.p. brass for pop-up waste with drain 1"1/4.

95TAG



Tappo grande quadrato in ottone cromato per scarico automatico con piletta da 1"1/4.
Squared big plug in c.p. brass for pop-up waste with drain 1"1/4.

95TAS



Tappo in ottone cromato per colonna vasca automatica.
Chrome plated brass plug for automatic bath waste and overflow.

96TA



Basetta in ottone per rubinetteria tipo serie Kiss, Ten, Giga.
Base in c.p. brass for mixers like serie Kiss, Ten, Giga.

BAK10



Asta per scarico automatico, lunghezza cm 30, in ottone cromato.
Rod for pop-up waste, length 30 cm, in c.p. brass.

94



Asta e centralina bidet per scarico automatico, in ottone cromato.
Rod and flange for bidet for pop-up automatic waste, in c.p. brass.

95AC



Asta e centralina bidet per scarico automatico, in ottone cromato.
Rod and flange for bidet for pop-up automatic waste, in c.p. brass.

95QAC



Asta con pomolo e snodino per serie Ten, in ottone cromato.
Rod with knob and small joint for Ten series, in c.p. brass.

AST10



Asta con pomolo e snodino per serie Kiss, in ottone cromato.
Rod with knob and small joint for Kiss series, in c.p. brass.

ASK10



Asta per scarico automatico in ottone.
Rod for pop-up waste in brass.

ASX10



Confezione di fissaggio per art. K10, K20, K40.
Fixing set for art. K10, K20, K40.

FISK10



Confezione di fissaggio per art. R10, R20, R40.
Fixing set for art. R10, R20, R40.

FISR10



Confezione di fissaggio a doppio tirante.
Fixing set with double screw.

FIST10



Confezione di fissaggio per: Atmos, Flash, Qubika Cascata.
Fixing set for: Atmos, Flash, Qubika Waterfall.

FISA10



Confezione di fissaggio per art. S42 U, S10 G, B10, B20, Q42U, Q10 G.
Fixing set for art. S42 U, S10 G, B10, B20, Q42U, Q10 G.

FISB10

ACCESSORI PER LAVABO - WASH BASIN ACCESSORIES



Copriforo per lavabo, Ø mm 50 in ottone cromato, tipo pesante.
Tap-hole-cover for wash basin Ø 50 mm in C.P. brass, heavy type.

695



Copriforo per lavabo, Ø mm 50 verniciato bianco, tipo pesante.
Tap-hole-cover for wash basin Ø 50 mm in white color, heavy type.

695BI



Copriforo per lavabo Ø mm 44, in acciaio inox.
Tap-hole-cover for wash basin Ø 44 mm, in stainless steel.

694



Griglietta copripiletta in acciaio inox.
Grate for sink waste in stainless steel.

696



Griglia copripiletta in acciaio inox, Ø esterno mm 70.
Grate for sink waste in stainless steel, external Ø 70 mm.

696B



Tappo in PVC nero, con maniglia Ø mm 52.
Plug in black PVC, with handle Ø mm 52.

69252



Tappi con catena e anello, con rosetta copritappo.
Plugs with chain and chain ring, with coverhole flange.

69040 Ø40 mm

69047 Ø47 mm

69052 Ø 52 mm



Tappi con catena e reggicatena, con rosetta copritappo.
Plugs with chain, chain-ring and holder, with coverhole flange.

69131 Ø31 mm

ACCESSORI PER LAVELLO - SINK ACCESSORIES



Piletta simplex 1"1/4.
Simplex waste 1"1/4.

903114



Piletta gattinara, Ø 70. 1"1/4.
Waste, Ø 70. 1"1/4

903SM114

ACCESSORI PER WC ED ORINATOI - WC AND ORINALS ACCESSORIES



Pull bianchi con catena a perline.
Pull handle for wc flushing tank, with C.P. chain.

699

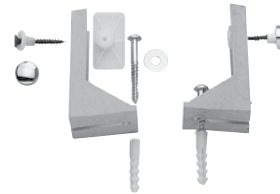

Coppia zanche in plastica antiurto a L con viti, per fissaggio laterale W.C. e bidet.
Couple wall brackets in plastic, shock-resistant, L shaped, with screws, for side WC and bidet fixing.

733



Confezione fissa water-bidet composta da 4 viti ottone, 4 dadi ottone, 4 sottoviti, 4 tasselli.
Bag for fixing W.C.-bidet: 4 brass screws, 4 caps, 4 underscrews, 4 nuts.

715



Confezione fissa water-bidet composta da 4 viti ferro, 4 dadi ottone, 4 sottoviti, 4 tasselli.
Bag for fixing W.C.-bidet: 4 iron screws, 4 caps, 4 underscrews, 4 brass nuts.

715F



Confezione fissa water-bidet composta da 2 viti ferro, 2 dadi ottone, 2 sottoviti, 2 tasselli.
Bag for fixing W.C.-bidet: 2 iron screws, 2 caps, 2 underscrews, 2 brass nuts.

715F2

RUBINETTERIA
TAPS

FLESSIBILI
FLEXIBLE HOSES

MINUTERIA
MINUTERY

VALVOLE
VALVES

RACCORDERIA
FITTINGS

ACCESSORI
ACCESSORIES

COMPONENTI PLASTICI
PLASTIC COMPONENTS



Coppia supporti per sedile WC, in nylon bianco completa di bulloni con guida.
Set of 2 holding brackets for WC seat, in white nylon, complete with bolts and slide way.

745



Coppia supporti per sedile WC, in ottone cromato con viti di fissaggio.
Set of 2 holding brackets in c.p. brass for WC seat, complete with bolts and slide way

746

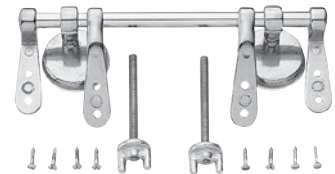

Coppia cerniere per sedile WC, in ottone cromato, tipo con tubetto per sedili in legno, con 8 viti in ottone.
Couple hinges for WC seat, in C.P. brass, kind with pipe for wooden seats, with 8 brass screws.

747

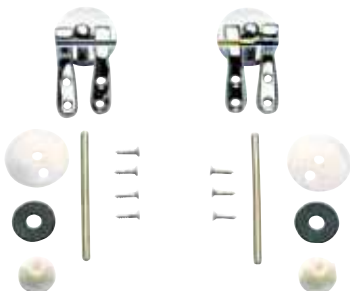

Coppia cerniere per fissaggio sedili W.C. in legno, con 8 viti in ottone.
Couple hinges for fixing W.C. seats, with 8 screws.

748



Coppia cerniere in ottone cromato, tipo universale, per fissaggio sedili W.C. in legno, con 8 viti in ottone.
Couple hinges in C.P. brass, universal type, for fixing W.C. seats, with 8 screws.

748UNI

ACCESSORI - ACCESSORIES



Coppia viti con tassello in acciaio per lavabo, lunghezza mm 120, 140.
Bag of 2 screws 120, 140 mm for wash-basin, with plastic nuts.

750120 mm120

750140 mm140



Coppia viti per lavabo semi incasso con tassello, lunghezza mm 180.
Bag of 2 screws for semi-recessed basin, with nut, length mm 180.

751180 mm180



Coppia viti Ø mm 8 con tassello e dado per cassetta W.C., lunghezza mm 90.
Couple screws Ø mm 8 with plastic screw anchors and nut, for WC flushing tank, length mm 90.

75290 mm90



Coppia tiranti con gancio e tassello in acciaio per scaldabagno, lunghezza mm 75, 100.
Bag of 2 screws, 75, 100 mm for water-heater, with plastic nuts.

75575 mm75

755100 mm100

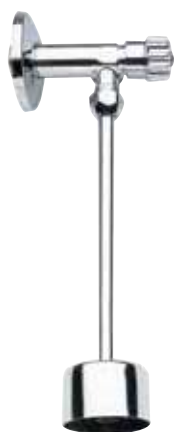

Rubinetto per orinatoio a maniglia, 1/2 con tubetto Ø mm 10 e rosoni.
C.P. urinal valve, 1/2, with copper pipe Ø 10 and C.P. brass flanges.

855



Spartiacque per orinatoio attacco Ø 15, con tubo Ø mm 15.
Water divide for urinal, connection Ø 15, with pipe Ø mm 15.

856



Spartiacque per orinatoio attacco Ø 15, per tubo Ø mm 15.
Water divide for urinal, connection Ø 15, for pipe Ø mm 15.

856CO

ACCESSORI PER DOCCIA - SHOWER ACCESSORIES

Canaline Sifonate Rettangolari - Rectangulars Floor Drains



Canalina sifonata a pavimento, in inox, con griglia di drenaggio, larghezza 12.5 cm lunghezze cm 70, 80, 90, 100, 120.
Rectangular floor drain, in stainless steel, with drain grill, large 12.5 cm, lengths cm 70, 80, 90, 100, 120.

913RG1270 70 cm

913RG1280 80 cm

913RG1290 90 cm

913RG12100 100 cm

913RG12120 120 cm



Canalina sifonata a pavimento, in inox, piastrellabile, larghezza 12,5 cm lunghezze cm 70, 80, 90, 100, 120.
Rectangular floor drain, in stainless steel, model for tiling, large 12,5 cm, lengths cm 70, 80, 90, 100, 120.

913RP1270 70 cm

913RP1280 80 cm

913RP1290 90 cm

913RP12100 100 cm

913RP12120 120 cm

Pilette Sifonate - Siphon Drains



Piletta da pavimento sifonata in inox, cm 10x10.
Stainless steel floor drain and siphon, cm 10x10.

913SF10



Piletta da pavimento sifonata in inox, cm 15x15.
Stainless steel floor drain and siphon, cm 15x15.

913SF15



Piletta da pavimento sifonata in inox, cm 20x20.
Stainless steel floor drain and siphon, cm 20x20.

913SF20

RUBINETTERIA
TAPS

FLESSIBILI
FLEXIBLE HOSES

MINUTERIA
MINUTERY

VALVOLE
VALVES

RACCORDERIA
FITTINGS

ACCESSORI
ACCESSORIES

COMPONENTI PLASTICI
PLASTIC COMPONENTS

Copertura a pavimento in acciaio inox - Stainless steel floor drains

10x10



Copertura a pavimento in inox cm 10x10, con griglia fissa e coperchio mobile.
Stainless steel floor drain cm 10x10, with fixed grill and movable plug.

913GVC10



Copertura a pavimento in inox cm 10x10, con griglia fissa.
Stainless steel floor drain cm 10x10, with fixed grill.

913GV10



Copertura a pavimento in inox cm 15x15, con griglia fissa e coperchio mobile.
Stainless steel floor drain cm 15x15, with fixed grill and movable plug.

913GVC15



Copertura a pavimento in inox cm 15x15, con griglia fissa.
Stainless steel floor drain cm 15x15, with fixed grill.

913GV15

15x15



Copertura a pavimento in inox cm 15x15, con coperchio avvitato fisso.
Stainless steel floor drain cm 15x15, with fixed plug.

913CV15



Copertura a pavimento in inox cm 15x15, con griglia e coperchio mobili.
Stainless steel floor drain cm 15x15, with movable grill and movable plug.

913GFC15

20x20



Copertura a pavimento in inox cm 20x20, con griglia fissa e coperchio mobile.
Stainless steel floor drain cm 20x20, with fixed grill and movable plug.

913GVC20



Copertura a pavimento in inox cm 20x20, con griglia fissa.
Stainless steel floor drain cm 20x20, with fixed grill.

913GV20



Copertura a pavimento in inox cm 20x20, con coperchio avvitato fisso.
Stainless steel floor drain cm 20x20, with fixed plug.

913CV20



Copertura a pavimento in inox cm 20x20, con griglia e coperchio mobili.
Stainless steel floor drain cm 20x20, with movable grill and movable plug.

913GFC20

Sifoni Anti Scarafaggio - Anti Cockroach-Insects Trap



Sifone anti-scarafaggio da utilizzare per coperture a pavimento cm 15x15 e 20x20.
Anti cockroach-insects to use under the floor drains with size cm 15x15 e 20x20.

913PSA01

15-20cm



Sifone anti-scarafaggio da utilizzare per coperture a pavimento cm 10x10.
Anti cockroach-insects to use under the floor drains with size cm 10x10.

913PSA02

10 x 10cm

SCARICHI AUTOMATICI - POP-UP WASTES



Scarico automatico 1", 1"1/4.
C.P. brass pop-up waste, 1", 1"1/4.

95



Scarico automatico da 1"1/4, tipo Lusso.
C.P. brass pop-up waste 1"1/4, luxury type.

95L80



Scarico automatico da 1"1/4, tipo lusso lucidato, con tappo grande a copertura totale della piletta.
C.P. polished pop-up waste, 1"1/4, luxury type with big plug covering the drain.

95LG80



Scarico automatico in plastica da 1"1/4.
Plastic pop-up waste, 1"1/4.

95P80



Scarico automatico da 1"1/4, tipo lusso lucidato, con tappo grande quadrato piatto a copertura totale della piletta.
C.p. polished pop-up waste, 1"1/4, luxury type with big squared flat plug covering the drain.

95LS80



Scarico tipo America o Americano, in ottone pulito e cromato.
C.p. waste model America or American, polished and in c.p. brass.

95AM

SCARICHI AUTOMATICI CLICK-CLACK - AUTOMATIC CLICK-CLACK POP-UP WASTES



Scarico automatico con sistema click-clack, 1"1/4, e tappo grande, senza troppo pieno, modello con bicchiere corto.
Automatic pop-up waste 1"1/4, click-clack system, big plug, without overflow, model with shorter cup.

904CC2114



Scarico automatico con sistema click-clack, 1"1/4, e tappo grande, senza troppo pieno.
Automatic pop-up waste 1"1/4, click-clack system, big plug, without overflow.

904CC114



Scarico automatico quadrato 1"1/4 con click-clack senza troppo pieno, modello con bicchiere corto.
Squared automatic pop-up waste 1"1/4 with click-clack system without overflow, model with shorter cup.

904SCC2114



Scarico automatico quadrato 1"1/4 con click-clack senza troppo pieno.
Squared automatic pop-up waste 1"1/4 with click-clack system without overflow.

904SCC114



Scarico automatico con sistema click-clack, 1"1/4, con troppo pieno, modello con bicchiere corto.
Automatic pop-waste 1"1/4, click-clack system, with overflow, model with shorter cup.

906CC2114



Scarico automatico con sistema click-clack, 1"1/4, con troppo pieno.
Automatic pop-up waste 1"1/4, click-clack system, with overflow.

906CC114



Scarico automatico con sistema click-clack, 1"1/4, e tappo grande, con troppo pieno, modello con bicchiere corto.
Automatic pop-up waste 1"1/4, click-clack system, big plug, with overflow., model with shorter cup

905CC2114



Scarico automatico con sistema click-clack, 1"1/4, e tappo grande, con troppo pieno.
Automatic pop-up waste 1"1/4, click-clack system, big plug, with overflow.

905CC114



Scarico automatico quadrato 1"1/4 con click-clack con troppo pieno, modello con bicchiere corto.
Squared automatic pop-up waste 1"1/4 with click-clack system with overflow, model with shorter cup.

905SCC2114



Scarico automatico quadrato 1"1/4 con click-clack con troppo pieno.
Squared automatic pop-up waste 1"1/4 with click-clack system with overflow.

905SCC114



Scarico automatico 1"1/4 con tappo grande sempre aperto e sistema click-clack per la pulizia interna, modello con bicchiere corto.
Automatic pop-up waste 1"1/4 with big plug always opened, and click-clack system for internal cleaning, model with shorter cup.

9072114



Scarico automatico 1"1/4 con tappo grande sempre aperto e sistema click-clack per la pulizia interna.
Automatic pop-up waste 1"1/4 with big plug always opened, and click-clack system for internal cleaning.

907114



Scarico automatico universale con chiusura click-clack da 1"1/4.
Universal automatic pop-up waste 1"1/4 with click-clack system.

905CCR114



Scarico automatico con sistema click-clack, 1" 1/4, tappo grande, con troppo pieno, versione extralunga.
Automatic pop-up waste 1"1/4, click-clack system, big plug, with overflow, extralong version.

905CCXL114

RUBINETTERIA
TAPS

FLESSIBILI
FLEXIBLE HOSES

MINUTERIA
MINUTERY

VALVOLE
VALVES

RACCORDERIA
FITTINGS

ACCESSORI
ACCESSORIES

COMPONENTI PLASTICI
PLASTIC COMPONENTS

SIFONI - TRAPS



Sifone a "P" in tubo, in ottone cromato, 1" 1/4".
"P" trap made by tube, in c.p. brass, 1" 1/4".

977114



Sifone "P" in tubo, in acciaio INOX, 1" 1/4.
"P" trap made by tube, in stainless steel, 1" 1/4.

977X114



Sifone a bottiglia in ottone cromato, canotto cm 25, 1", 1" 1/4.
C.P. brass bottle trap, 25 cm outlet tube, 1", 1" 1/4.

97010

1"

970114

1"1/4



Sifone a "S" in ottone cromato, canotto cm 25, 1" 1/4.
C.P. brass "S" trap, 25 cm outlet tube, 1" 1/4.

971114

1"1/4



Sifone a "S" in zama, canotto cm 25, 1" 1/4.
"S" trap in zamac, 25 cm outlet tube, 1" 1/4.

971Z114



Sifone a "U" per lavabo a colonna in ottone cromato, canotto cm 25, 1" 1/4.
C.P. brass "U" trap, 25 cm outlet tube, 1" 1/4.

972114



Sifone "MINIMAL" in ottone cromato, per lavabo, 1" 1/4, canotto cm 30 e rosone pesante.
C.P. brass "MINIMAL" P trap, for wash-basin, 1" 1/4, outlet tube cm 30 and heavy flange.

958L



Sifone "MINIMAL" in ottone cromato, per bidet, 1" 1/4, canotto cm 30 e rosone pesante.
C.P. brass "MINIMAL" P trap, for bidet, 1" 1/4, outlet tube cm 30 and heavy flange.

958B



Sifone a bottiglia in zama senza pileta, per lavabo, 1" 1/4, canotto cm. 30.
Bottle trap in zamac without waste, for wash-basin, 1" 1/4, outlet tube cm 30.

970Z114



Sifone SQ, in ottone cromato, canotto cm 30, 1" 1/4, con rosone pesante quadrato in ottone cromato.
C.p. brass SQ trap, 30 cm outlet tube, 1" 1/4, with heavy square wall flange.

960114



Sifone fuso pesante lusso in ottone cromato, per lavabo e bidet 1", 1" 1/4 canotto cm 30.
C.P. brass luxury "P" trap, heavy type, 1", 1" 1/4, outlet tube cm 30.

95610

1"

956114

1"1/4

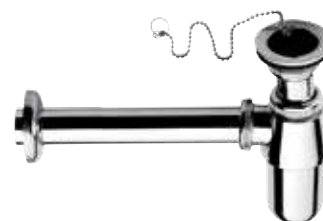

Sifone a bottiglia in zama con pileta, per lavabo, 1" 1/4.
Bottle trap in zamac with waste, for wash-basin, 1" 1/4.

973Z114



Sifone pesante in ottone fuso, con dado 1"1/2 per colonna vasca.
Heavy trap in casting brass, with nut 1"1/2 for bath waste and overflow.

98112



Ghiera per sifoni in ottone cromato, 1"M x 1"1/4 F, 1"1/4M x 1"1/2F.
C.P. brass reduction for trap 1"Mx1"1/4F, 1"1/4Mx1"1/2F.

96810M114F

1"Mx1"1/4F

968114M112F

1"1/4Mx1"1/2F



Ghiera per sifoni in ottone cromato, 1"1/4M x 1"F, 1"1/2M x 1"1/4F.
C.P. brass reduction for trap 1"1/4Mx1"F, 1"1/2Mx1"1/4F.

969114M10F

1"1/4Mx1"F

969112M114F

1"1/2Mx1"1/4F

RUBINETTERIA
TAPS

FLESSIBILI
FLEXIBLE HOSES

MINUTERIA
MINUTERY

VALVOLE
VALVES

RACCORDERIA
FITTINGS

ACCESSORI
ACCESSORIES

COMPONENTI PLASTICI
PLASTIC COMPONENTS

Sifoni salvaspazio - Space-saving traps



Sifone salvaspazio con piletta click-clack incorporata con troppo pieno, rotondo, cromato.
Space-saving traps with click-clack built-in drain with overflow, round, chrome.

985



Sifone salvaspazio con piletta click-clack incorporata senza troppo pieno, rotondo, cromato.
Space-saving traps with click-clack built-in drain without overflow, round, chrome.

984



Sifone salvaspazio con piletta click-clack incorporata con troppo pieno, quadrato, cromato.
Space-saving traps with click-clack built-in drain with overflow, squared, chrome.

985S



Sifone salvaspazio con piletta click-clack incorporata senza troppo pieno, quadrato, cromato.
Space-saving traps with click-clack built-in drain without overflow, squared, chrome.

984S

COLONNE DI SCARICO - BATH WASTES



Colonna di scarico automatica in plastica con filo esterno, senza dado e codolo.
Plastic combined bath waste with automatic pop-up with external wire.

96P



Colonna di scarico in plastica, con piletta "click-clack".
Plastic combined bath waste and overflow, "click-clack" waste system.

96PCC



Colonna di scarico con sifone per vasca con tubo in rame cromato e piletta click-clack, tutta cromata.
Bath brass waste with siphon, trap, chromated copper tube and click clack waste, all in chrome plated.

96LICC



Colonna di scarico con sifone per vasca con tubo in rame cromato, tutta cromata.
Bath brass waste with siphon, trap and chromated copper tube, all in chrome plated.

96LIT



Colonna di scarico automatica con filo esterno e tubo in rame senza dado e codolo.
C.P. brass automatic bath waste and overflow with external wire and copper tube.

96



Colonna di scarico con tubo in rame, con piletta "click-clack".
C.P. brass waste and overflow with copper tube and "click-clack" waste.

96CC



Colonna di scarico automatico con filo esterno e tubo in rame cm 70, per vasca ad angolo.
C.P. brass automatic bath waste, overflow and copper tube, cm 70, for bath tube edge.

96VA



Piletta doccia sifone, 1"1/4.
Trap drain for shower tray 1"1/4.

910114



Tappo ad espansione a 3 viti per sifone a pavimento,
Ø 100 mm.
Expansion plug with 3 nuts for floor trap, Ø 100 mm.

922100

RUBINETTERIA
TAPS

FLESSIBILI
FLEXIBLE HOSES

MINUTERIA
MINUTERY

ACCESSORI PER SCALDABAGNO - WATER HEATER ACCESSORIES

VALVOLE
VALVES



Resistenza per scaldabagno attacco 1"1/4 filettata, Watts 1200.
Straight heating element for water heater, 1"1/4, threaded cap, Watts 1200.

1111



Resistenza per scaldabagno attacco con flangia, Watts 1200.
Straight heating element for water heater, 1"1/4, flanged cap, Watts 1200.

1121



Resistenza per scaldabagni Ariston, con flangia, con tubetti prolungati, Watts 1200, 1"1/4.
Straight heating element for Ariston water heater, 1"1/4, flanged cap with longer pipes, Watts 1200.

1121AR

Resistenza per scaldabagno ricurva attacco 1"1/4 filettata, Watts 1200.
Bent heating element for water heater, 1"1/4, threaded cap, Watts 1200.

1112

Resistenza per scaldabagno ricurva attacco con flangia, Watts 1200.
Bent heating element for water heater, 1"1/4, flanged cap, Watts 1200.

1122

Resistenza ricurva per scaldabagni Ariston, con flangia, con tubetti prolungati, Watts 1200, 1"1/4.
Bent heating element for Ariston water heater, 1"1/4, flanged cap with longer pipes, Watts 1200.

1122AR

RACCORDERIA
FITTINGS

ACCESSORI
ACCESSORIES



Termostato per resistenza per scaldabagno, 1"1/4.
Round thermostat for water heater, 1"1/4.

1100



Guarnizione OR mm 36,10x43,16x3,53 per resistenza flangiata.
Oring washer in NBR mm. 36,10x43,16x5,53, for flanged heating elements.

1130



Guarnizione esente amianto Ø 44x51, per resistenza filettata.
Asbestosfree washer for threaded heating elements, Ø 44x51.

1131



Guarnizione in gomma anticalore (EPDM) 755H, Ø 44,5x36x4, per resistenza filettata.
Oring washer in EPDM, heating resistant, 755 H mm. 44,5x36x4, for threaded heating elements.

1132

COMPONENTI PLASTICI
PLASTIC COMPONENTS



COMPONENTI PLASTICI PLASTIC COMPONENTS



COMPONENTI PLASTICI - PLASTIC COMPONENTS



RUBINETTERIA
TAPS

FLESSIBILI
FLEXIBLE HOSES

MINUTERIA
MINUTERY

VALVOLE
VALVES

RACCORDERIA
FITTINGS

ACCESSORI
ACCESSORIES

COMPONENTI PLASTICI
PLASTIC COMPONENTS

COMPONENTI PLASTICI - PLASTIC COMPONENTS



Ermetic-past - Guarnipast (cartoni da 60 barattoli) in barattoli da Kg. 0,500.

Ermetic-past - Guarnipast, in cans of kgs 0,500 (each box contains 60 cans).

551



Extra Gas per impianti gas (cartoni da 60 barattoli) in barattoli da Kg.0,500.

Extra gas, for gas systems, in cans of kgs 0,500 (each box contains 60 cans).

552



Stearina in pacchi da Kg. 1.

Stearine in boxes of 1 Kg each.

555



Canapa pettinata in 4 matassine.

Combed hemp in 4 small strips skeins.

570

in sacchetto da 250gr (materiale venduto in pezzi).
in 250gr bags.

570BA250



Tappo di collaudo impianti, filetto in ottone, blu, 1/2".
Testing plug, thread in brass, blue colour, 1/2.

140BL12



Tappo di collaudo impianti, filetto in ottone, rosso, 1/2".
Testing plug, thread in brass, red colour, 1/2.

140RO12



Tappo di collaudo impianti, filetto in ottone, bianco, 1/2".

Testing plug, thread in brass, white colour, 1/2.

140BI12



Tappo di collaudo impianti, completamente in plastica blu, 1/2".

Testing plug, completely in plastic, blue colour, 1/2.

140BLPP



Tappo di collaudo impianti, completamente in plastica rosso, 1/2".

Testing plug, completely in plastic, red colour, 1/2.

140ROPP



Rosetta apribile universale in plastica bianca.
Wall flange, universal type in white plastic.

133



Rosetta apribile universale in plastica bianca.
Wall flange, universal type in white plastic.

134



Nastro P.T.F.E. in rullini da 1/2" per metri 10, spessore 0,075 mm.
P.T.F.E. Tape in rolls of 1/2", meters 10, thickness mm 0,075.

57210

Nastro P.T.F.E. in rullini da 1/2" per metri 12, spessore 0,075 mm.
P.T.F.E. Tape in rolls of 1/2", meters 12, thickness 0,075 mm.

57212

Nastro P.T.F.E. in rullini da 3/4, mm 19, per metri 12, spessore 0,075 mm. P.T.F.E. Tape in rolls of 3/4 (19 mm), meters 12, thickness 0,075 mm.

57234

Nastro P.T.F.E. in rullini da 1", mm 24, per metri 12, spessore 0,075 mm.
P.T.F.E. Tape in rolls of 1", (24 mm), meters 12, thickness 0,075 mm.

5721P



Nastro P.T.F.E. giallo professionale per gas, in rullini da mm 12 per metri 10, spessore mm 0,10, densità 1,20 g/cm³.

P.T.F.E. professional yellow tape for gas, in rolls of 12 mm, meters 10, thickness 0,10 mm, 1,20 g/cm³ density.

573



Nastro P.T.F.E. in rullini da mm 12 per metri 12, spessore mm 0,10.

P.T.F.E. Tape in rolls of 12 mm, meters 12, thickness 0,10 mm.

574



Nastro P.T.F.E. professionale per gas in rullini da mm 19 per metri 15, spessore mm 0,20.

P.T.F.E. Professional Tape for gas, in rolls of 19 mm, meters 15, thickness 0,20 mm

575



Nastro P.T.F.E. in rullini da 1/2" per metri 8, spessore 0,075 mm, stampato "RR".

P.T.F.E. Tape in rolls of 1/2", meters 8, thickness mm 0,075 with RR printed.

572



Nastro P.T.F.E. in rullini da mm 19,05 spessore mm 0,12, densità 0,30 g/cm³.

P.T.F.E. in rolls of 19,05 mm, thickness 0,12 mm, 0,30 g/cm³ density.

577 metri 30 - meters 30

57715 metri 15 - meters 15



Filo in P.T.F.E. professionale per ogni tipo di tubo in metallo e plastica di Ø inferiore a 6", per metri 150.

P.T.F.E. professional floss tape for pipe in metal or plastic, Ø up to 6", meters 150.

579



Liquido anticongelante ecologico puro tanica da 25kg. Pure ecological antifreeze liquid. 25kg tank.

554



Sigillante anaerobico flaconcino da 75ml. Anaerobic sealant, 75ml vial.

553

RUBINETTERIA
TAPS

FLESSIBILI
FLEXIBLE HOSES

MINUTERIA
MINUTERY

VALVOLE
VALVES

RACCORDERIA
FITTINGS

ACCESSORI
ACCESSORIES

COMPONENTI PLASTICI
PLASTIC COMPONENTS

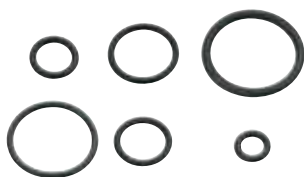

Anelli O'RING: in gomma NBR, rettificati, per tenuta a 120°C.

O-RINGS: in NBR rubber, applicable up to 120°C.

649R3	8,0X4,2X1,9
649R5	9,5X5,7X1,9
649R5A	10,2X6,4X1,9
649R6	11,0X7,2X1,9
649R6A	8,0X4,2X1,9
649R7	12,7X8,9X1,9
649R8	14,3X8,9X1,9
649R9	15,9X10,5X1,9
649R10	17,5X12,1X1,9
649R11	19,0X13,6X1,9
649R12	20,5X15,1X1,9



Scatola con 430 anelli "OR" per vitoni del tipo originale rettificato, assortiti in 12 misure da Ø esterno mm 8 al Ø esterno mm 20,5.

Box of 430 "OR" rings, assorted in 12 measures from external Ø mm 8 to external Ø mm 20,5.

648



Guarnizioni per raccordi senza amianto spessore mm 2 in conf. 100 pz.

Green washers, without asbestos in bags of 100 pcs thickness.

65038	3/8
65012	1/2
65034	3/4
65010	1"
650114	1"1/4
650112	1"1/2
65020	2"

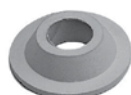

Guarnizioni coniche in gomma bianca. Washer conical seat in white rubber.

65212	1/2
65210	1"
652114	1"1/4
652112	1"1/2



Guarnizioni con bordino in gomma bianca. Washer with reinforcement collar in white rubber.

65312	1/2
65334	3/4
65310	1"
653114	1"1/4
653112	1"1/2



Guarnizioni per radiatori in ghisa, spessore mm 2, misure 1"1/4.

Washer for iron radiators, thickness mm 2, size 1"1/4.

6582114	1"1/4
----------------	-------

Guarnizioni per radiatori in alluminio, spessore mm 1, 1".

Washer for aluminium radiators, thickness mm 1, size 1".

659110	
---------------	--

Guarnizioni per radiatori in alluminio, spessore mm 2, 1".

Washer for aluminium radiators, thickness mm 2, size 1".

659210	
---------------	--



Guarnizione sede piana con filtro retinato. Washer plain seat with net filter.

662F112	1/2
662F134	3/4



Guarnizioni sede tonda Ø18 in gomma NBR per canne lavello.

Washers round seat in black Ø18, rubber NBR, for sink spout.

661CN18	
----------------	--



Anello in para Ø esterno mm 60 - interno mm 44, sezione a U per cassetta Pucci.

Caoutchouc rubber external Ø mm 60, internal Ø mm 44, with U section for Pucci WC flushing tank.

671PU	
--------------	--



Guarnizione per Idronitor in para Ø esterno mm 68, Ø foro interno mm 33.

Washer for Idronitor in caoutchouc rubber, external Ø mm 68, internal hole Ø mm 33.

671ID	
--------------	--



Membrana in para Ø esterno mm 58,5, Ø foro mm 18,5 per cassetta Kariba.

Caoutchouc rubber flushing tank bottom seal washer, suitable for Kariba, external Ø mm 58,5, hole Ø mm 18,5.

672KB	
--------------	--



Guarnizioni sede tonda in gomma NBR.
Washers round seat in black rubber NBR.

66138	3/8
66112	1/2
66134	3/4
66110	1"
661114	1"1/4
661112	1"1/2



Guarnizioni sede piana in gomma nera.
Washers plane seat in black rubber.

66238	3/8
66212	1/2
66234	3/4
66210	1"
662114	1"1/4
662112	1"1/2



Guarnizione sede conica in gomma nera.
Washer conical seat in black rubber.

66334	3/4
66310	1"
66330	Ø 30
663114	1"1/4
663112	1"1/2



Guarnizione sede rubinetto in gomma, collaudate a 200.000 chiusure con acqua a 80°.
Water taps sealing with hole, in rubber tested with 200.000 cycles.

66538	3/8
66512	1/2



Guarnizioni sede rubinetto in gomma, con foro.
Wall tap sealing with hole, in rubber.

66638	3/8
66612	1/2
66634	3/4



Guarnizioni sede rubinetto in silicone bianche.
Water tap sealing in white sylicone.

666SI38	3/8
666SI12	1/2



Guarnizioni a scodellino in gomma nera.
Washer, cup shaped, in black rubber.

669185	Ø 18,5
66924	Ø 24



Guarnizioni a scodellino per galleggiante Catis originale Ø 20 mm con perno.
Washer cup shaped for original Catis float valve, Ø 20 mm, with dowel.

669CA	
--------------	--



Guarnizioni a scodellino per galleggiante art. 176, 174 AS.
Washer cup shaped for ofloat valve art 176, 174 AS.

669RE	
--------------	--



Membrana in para Ø esterno mm 63, Ø foro mm 22, per cassetta Fait.
Caoutchouc rubber flushing tank bottom seal washer, suitable for Fait, external Ø mm 63, hole Ø mm 22.

672FA	
--------------	--



Guarnizione per cassetta Idron in para nera, Ø est mm 56, Ø foro mm 25, spessore mm 3,6.
Caoutchouc rubber flushing tank bottom seal washer, suitable for Idron, external Ø mm 56 hole Ø mm 25, thickness mm 3,6.

672ID	
--------------	--

COMPONENTI PLASTICI - PLASTIC COMPONENTS



Asta completa con sfera per cassetta Nuova Dora incasso 14 litri.

Complete set of rod and ball for Nuova Dora built-in 14 liters flushing tank.

673ND14



Valvola mezza sfera in para Ø est. mm 35, con nottolino ottone filetto 5/32 per batteria Catis.

Caoutchouc half sphere washer, external Ø mm 35, with brass nut, thread 5/32, for Catis group set.

674CA



Valvola mezza sfera in para Ø est. mm 35, senza nottolino ottone filetto 5/32 per batteria Catis.

Caoutchouc half sphere washer, external Ø mm 35, without brass nut, thread 5/32, for Catis group set.

674CASN



Morsetto per W.C. in gomma nera, Ø esterno mm 50, per canotti Ø 26, 30, 32.

Clamp gasket for WC in black rubber, external Ø mm 50, for pipes Ø 26, 30, 32.

679502632



Morsetto per W.C. in gomma nera, Ø esterno mm 55, per canotti Ø 26, 30, 32.

Clamp gasket for WC in black rubber, external Ø mm 55, for pipes Ø 26, 30, 32.

679552632



Morsetto per W.C. in gomma nera, Ø esterno mm 55, per canotti Ø 40.

Clamp gasket for WC in black rubber, external Ø mm 55, for pipes Ø 40.

6795540



Sfera in para Ø esterno mm 55, con foro passante Ø mm 14, per cassetta Nuova Dora.

Ball in caoutchouc rubber for Dora WC flushing tank, external Ø mm 55, with passing hole Ø mm 14.

676ND



Morsetto per W.C. in gomma, Ø esterno mm 54, per canotti Ø 26, 30, 32.

Clamp gasket for W.C. in rubber, external Ø 54 mm, for pipe Ø 26, 30, 32.

679



Morsetto per W.C. in gomma nera, Ø esterno mm 60, per canotti Ø 26, 30, 32.

Clamp gasket for WC in black rubber, external Ø mm 60, for pipes Ø 26, 30, 32.

679602632



Raccordo per W.C. in para.
Connection for WC in caoutchouc rubber.

677



Morsetto per W.C. Standard in gomma bianca, Ø esterno mm 60, per canotti Ø 30, 32.

Clamp gasket for W.C. in white rubber, standard type, external Ø 60 mm, for pipe Ø 30, 32.

680ST



Morsetto per W.C. Standard in gomma bianca, Ø esterno mm 60, per canotti Ø 40.

Clamp gasket for W.C. in white rubber, standard type, external Ø 60 mm, for pipe Ø 40.

680ST40



Raccordo in gomma nera Nicoll, Ø esterno mm 50, per canotti Ø 26.
Connector in black rubber Nicoll, external Ø 50 mm, for pipe Ø 26.

6825026



Raccordo in gomma nera Nicoll, Ø esterno mm 50, per canotti Ø 30, 32.
Connector in black rubber Nicoll, external Ø 50 mm, for pipes Ø 30, 32.

6825032



Raccordo in gomma nera Nicoll, Ø esterno mm 50, per canotti Ø 40.
Connector in black rubber Nicoll, external Ø 50 mm, for pipe Ø 40.

6825040



Raccordo in gomma nera per Von Roll, Ø esterno mm 50 per canotti Ø 26, 30, 32.
Connector in black rubber for Von Roll, external Ø 50 mm for pipes Ø 26, 30, 32.

684502632



Raccordo in gomma nera per Von Roll, Ø esterno mm 50 per canotti Ø 40.
Connector in black rubber for Von Roll, external Ø 50 mm for pipe Ø 40.

6845040



Raccordo in gomma nera per Geberit, Ø esterno mm 47 per canotti Ø 26, 30, 32.
Connector in black rubber for Geberit, external Ø 47 mm for pipes Ø 26, 30, 32.

686472632



Raccordo in gomma nera per Geberit, Ø esterno mm 47 per canotti Ø 40.
Connector in black rubber for Geberit, external Ø 47 mm for pipe Ø 40.

6864740



Prolunga W.C. in gomma nera, Ø esterno mm 111, Ø interno mm 95, altezza mm 92.
Wc extension in black rubber, external Ø mm 111, internal Ø mm 95, thickness mm 92.

689



Prolunga W.C. in gomma bianca, Ø esterno mm 111, Ø interno mm 95, altezza mm 92.
W.C. white rubber connector, ext. Ø mm 111, int. Ø mm 95, height mm 92.

689B



Collare sottovaso in gomma nera, Ø esterno mm 110, Ø interno mm 90.
Collar in black rubber for under WC bowl, internal Ø mm 90, external Ø mm 110.

68811090



Collare sottovaso in gomma nera, Ø esterno mm 120, Ø interno mm 90.
Collar in black rubber for under WC bowl, internal Ø mm 90, external Ø mm 120.

68812090



Ghiera per troppo pieno per lavabo e bidet, dorata.
Golden nut for basin and bidet overflow.

700DO13 Ø 13

700DO19 Ø 19

700DO24 Ø 24

700DO28 Ø 28

COMPONENTI PLASTICI - PLASTIC COMPONENTS



Raccordo in gomma nera per Redi, Ø esterno mm 32, per canotti Ø 26.
Fitting in black rubber for Redi, Ø external mm 32, for pipe Ø 26.

6873226



Raccordo in gomma nera per Redi, Ø esterno mm 40, per canotti Ø 26.
Fitting in black rubber for Redi, Ø external mm 40, for pipe Ø 26.

6874026



Raccordo in gomma nera per Redi, Ø esterno mm 40, per canotti Ø 32.
Fitting in black rubber for Redi, Ø external mm 40, for pipe Ø 32.

6874032



Raccordo in gomma nera per Redi, Ø esterno mm 50, per canotti Ø 26.
Fitting in black rubber for Redi, Ø external mm 50, for pipe Ø 26.

6875026



Raccordo in gomma nera per Redi, Ø esterno mm 50, per canotti Ø 32.
Fitting in black rubber for Redi, Ø external mm 50, for pipe Ø 32.

6875032



Prolunga W.C. in gomma, eccentrica Ø esterno mm 138, Ø interno mm 100, altezza mm 100.
W.C. white rubber connector, eccentric, ext. Ø mm 138, int. Ø mm 100, height mm 100.

689EC



Prolunga W.C. in gomma, eccentrica Ø esterno mm 138, Ø interno mm 100, altezza mm 160.
W.C. white rubber connector, eccentric, ext. Ø mm 138, int. Ø mm 100, height mm 160.

689ECL



Prolunga W.C. in propilene, eccentrica Ø esterno mm 138, Ø interno mm 100, altezza mm 125.
W.C. white propylene connector, eccentric, ext. Ø mm 138, int. Ø mm 100, height mm 125.

689RI



Rullino per portarotoli in plastica bianca con molla inox.
Toilet roll holder rod in white plastic with stainless steel spring.

698



Ghiera per troppo pieno per lavabo e bidet, cromata.
C.P. Nut for basin and bidet overflow.

70013 Ø 13

70019 Ø 19

70024 Ø 24

70028 Ø 28



Sifone in plastica regolabile con dado ottone 1 1/2 per colonna, con scarico innesto Ø 40, 50, e a saldare.
Adjustable low trap for bathtub in black PEHD, inlet nut 1 1/2, outlet to weld Ø 40, 50.

98P112 1 1/2



Sifone in plastica regolabile con dado ottone 1 1/2 per colonna, con scarico ad incollare Ø 32, 40, 50.
Adjustable low trap for bathtub in grey PVC, inlet nut 1 1/2, outlet to glue Ø 32, 40, 50.

98INC112 1 1/2



Sifone in plastica per vasca, 1 1/2 x 40.
Siphon for bathtub in white P.P., 1 1/2 x 40.

911112



Piletta sifonata Ø 80 per piatto doccia 1 1/2 x 40.
Waste and siphon for shower trays, in white P.P., S.S. grid Ø 80 mm, outlet plastic nut 1 1/2 x 40.

912112



Piletta doccia sifoide in plastica con attacco Geberit, piletta in ottone cromato, Ø 40, 50, a saldare.
Siphon-waste for shower trays, in black PEHD, C.P. brass waste, outlet to weld Ø 40, 50 mm.

914GE



Raccordo in plastica curvo per attacco Geberit Ø 40, con dado ottone, 1 1/4, 1 1/2.
Elbow plastic connection for Geberit connection Ø 40, with brass nut 1 1/4, 1 1/2.

916114 1 1/4

916112 1 1/2



Raccordo in PVC curvo per attacco Nicoll, con dado ottone, 1"1/4, 1"1/2.
Elbow connection in PVC for Nicoll connection, with brass nut, 1"1/4, 1"1/2.

917C114 1"1/4

917C112 1"1/2



Raccordo in PVC diritto per attacco Nicoll, con dado ottone, 1"1/4.
Straight connection in PVC for Nicoll connection, with brass nut, 1"1/4.

917D114 1"1/4



Piletta per doccia con piastra cromata Ø 120, con uscita scarico Ø mm 40, per piatto doccia con foro Ø 90 mm.
Waste for shower tray, with chrome plated cover Ø 120, outlet pipe mm 40, for shower tray with hole Ø 90 mm.

914120



Piletta per doccia con piastra cromata Ø 90, con uscita scarico Ø mm 40, per piatto doccia con foro Ø 60 mm.
Waste for shower tray, with chrome plated cover Ø 90, outlet pipe mm 40, for shower tray with hole Ø 60 mm.

91490



Colonna vasca semplice in plastica con tubo di collegamento corrugato in P.P., 1"1/2.
Corrugated plastic combined waste and overflow set for bathtub, in white P.P., S.S. grid, plug and chain. Male outlet 1"1/2.

931



Colonna vasca semplice in plastica con tubo di collegamento estensibile in P.P., 1"1/2.
Extensible plastic combined waste and overflow set for bathtub, in white P.P., S.S. grid, plug and chain. Male outlet 1"1/2.

932 1"1/2



Canotto flessibile estensibile resistente da +90° a -10°C, colore bianco, con dado in plastica e un manicotto.
Flexible and extensible plastic tube resisting from +90° to -10°C, white colour, with plastic nut and one coupling.

93311432 1"1/4 x Ø32 mm

9331143240 1"1/4 x Ø32/40 mm

93311240 1"1/2 x Ø40 mm

9331124050 1"1/2 x Ø40/50 mm



Canotto flessibile estensibile resistente da +90° a -10°C, colore bianco, con due manicotti, Ø manicotto mm 32, 40.
Flexible and extensible tube resisting from +90° to -10°C, white colour, with double coupling Ø mm 32, 40.

93632 Ø 32

93640 Ø 40



Come 933, con dado in ottone, con rosone art. 933 RO.
As 933, with brass nut and with flange art. 933 RO.

933B1032 1" x Ø32 mm

933B11432 1"1/4 x Ø32 mm

933B1143240 1"1/4 x Ø32/40 mm

933B11240 1"1/2 x Ø40 mm

933B1124050 1"1/2 x Ø40/50 mm

RUBINETTERIA
TAPS

FLESSIBILI
FLEXIBLE HOSES

MINUTERIA
MINUTERY

VALVOLE
VALVES

RACCORDERIA
FITTINGS

ACCESSORI
ACCESSORIES

COMPONENTI PLASTICI
PLASTIC COMPONENTS

COMPONENTI PLASTICI - PLASTIC COMPONENTS



Set composto da canotto flessibile 1"1/2 x Ø mm 40 nostro articolo 933 112 40 + piletta simplex 1"1/2 ns articolo 1005SM112.

Set composed by flexible and extensible plastic tube 1"1/2 x Ø mm 40 our article 933 112 40 + simplex waste 1"1/2 our article 1005SM112.

9331005SM2



Set composto da canotto flessibile 1"1/4 x Ø mm 32/40 nostro articolo 933 114 3240 + piletta simplex 1"1/4 ns articolo 1005SM114.

Set composed by flexible and extensible plastic tube 1"1/4 x Ø mm 32/40 our article 933 114 3240 + simplex waste 1"1/4 our article 1005SM114.

9331005SM4



Rosone in plastica per art. 933, Ø mm 40.
Plastic flange for art.933, Ø mm 40.

933RO40 Ø 40



Riduzione in plastica per art. 933 1"1/2M x 1"1/4F.
Plastic reduction for art.933 1"1/2M x 1"1/4F.

933RI



Tubo estensibile per collegamento w.c., estensibile da mm 230 a mm 570, diametro raccordo w.c. da mm 90 a mm 110.

Flexible and extensible plastic tube for W.C., extensible from 230 mm to 570 mm, diameter for W.C. from 90 mm to 110 mm.

944

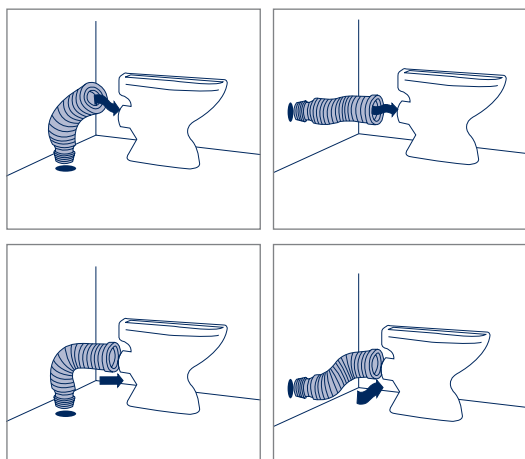

Manicotto estensibile e flessibile per W.C. estensibile da 270 mm a 540 mm, resistente e rinforzato in acciaio, guarnizione universale da 90 a 110 mm.

Extensible plastic pipe connection for W.C. reinforced with metal spiral, extensible from 270 to 540 mm, diameter for W.C. from 90 mm to 110 mm.

943



Manicotto per W.C., tipo corto, resistente e rinforzato con spirale in filo di nylon, guarnizione universale da 90 a 110 mm, lunghezza cm 40.

Flexible PVC plastic pipe connection for W.C. reinforced with nylon spiral, from 90 mm to 110 mm, length 40 cm.

945C



Manicotto per W.C., tipo lungo, resistente e rinforzato con spirale in filo di nylon, guarnizione universale da 90 a 110 mm, lunghezza cm 55.

Flexible PVC plastic pipe connection for W.C. reinforced with nylon spiral from 90 mm to 110 mm, length 55 cm.

945L



Piletta in polipropilene senza troppo pieno per lavelli in inox, 1"1/2.
Waste without overflow, in polypropylene, for stainless steel sinks, 1"1/2.

1025112



Piletta basket per lavelli, in polipropilene, con griglia e tappo inox, Ø 90 mm, (3"1/2, con filetto uscita 1"1/2).
Waste basket for sinks in polypropylene, with S.S. grid and plug, Ø 90 mm, (3"1/2, outlet thread 1"1/2).

1028112



Riduzione 1"1/4Mx1"1/2F in polipropilene.
Reduction in polypropylene, 1"1/4Mx1"1/2F.

1007



Piletta in polipropilene per lavelli in ceramica, con griglia in acciaio, 1"1/4, 1"1/2.
Waste in polypropylene for ceramic sinks, with S.S. grid, 1"1/4, 1"1/2.

1005114 1"1/4

1005112 1"1/2



Piletta "Simplex" in polipropilene con griglia in acciaio, 1"1/4 (per lavelli in acciaio), 1"1/2 (per lavabo).
Simplex waste in polypropylene, with S.S. grid, 1"1/4 (for stainless steel sinks), 1"1/2 (for wash basin).

1005SM114 1"1/4

1005SM112 1"1/2



Attacco lavatrice universale in polipropilene, 1"1/2x40.
Extension pipe for washing machine, in polypropylene, universal type, 1"1/2x40

1015



Piletta in polipropilene con troppo pieno per lavelli in inox, 1"1/2.
Waste with overflow, in polypropylene, for stainless steel sinks, 1"1/2.

1020112



Tubo di cacciata per cassetta alta, universale (45°/90°, 90°/90°).
Connection pipe for high wc tanks, universal type (45°/90°, 90°/90°).

1233



O-ring per art. 1233.
x O-ring for art. 1233.

1230OR

RUBINETTERIA
TAPS

FLESSIBILI
FLEXIBLE HOSES

MINUTERIA
MINUTERY

VALVOLE
VALVES

RACCORDERIA
FITTINGS

ACCESSORI
ACCESSORIES

COMPONENTI PLASTICI
PLASTIC COMPONENTS

Condizioni generali di vendita

Accettazione ordini

La commissione è sempre subordinata all'approvazione della Casa Venditrice. Le condizioni di vendita si intendono accettate dal committente al momento del conferimento dell'ordine e con il ritiro del materiale.

Consegne e rese

La merce è resa franco deposito di partenza e viaggia a rischio e pericolo del committente. Il venditore si riserva di poter effettuare consegne parziali.

Spedizioni

Le quantità devono essere verificate all'atto del ricevimento ed eventuali discordanze vanno annotate sulla bolla di consegna mediante accettazione "con riserva". Eventuali spese aggiuntive per giacenze sono a carico del committente.

Imballaggio

L'imballaggio è effettuato con imballi standard ed eventualmente su pallets a carico del committente.

Termini di consegna

I termini di consegna, eventualmente indicati, sono sempre forniti a puro titolo indicativo e non vincolante.

Prezzi

I prezzi riportati nei listini non sono vincolanti. La Remer Rubinetterie S.p.A. si riserva la facoltà di variare i prezzi di vendita in qualsiasi momento senza nessun preavviso.

Pagamenti

L'eventuale ritardo del pagamento comporterà l'addebito di interessi al tasso corrente. La Remer Rubinetterie S.p.A. si riserva la facoltà di sospendere eventuali ordini in corso in presenza di pagamenti irregolari. Le contestazioni di qualsiasi valore o entità non danno diritto alla sospensione dei pagamenti.

Reclami

Non si accettano reclami o resi merce dopo 7 giorni dal ricevimento della stessa. I reclami devono pervenire entro i termini indicati tramite lettera raccomandata e via fax. Ogni reso deve essere preventivamente autorizzato dalla Remer Rubinetterie S.p.A. che fornirà istruzioni in merito.

Caratteristiche tecniche

La Remer Rubinetterie S.p.A. si riserva il diritto di effettuare modifiche tecniche ed estetiche sui prodotti, senza preavviso alla clientela.

Riservato dominio

I prodotti rimangono di proprietà della Remer Rubinetterie S.p.A. fino al totale pagamento del prezzo in conformità a quanto previsto dal C.C.

Responsabilità

La Remer Rubinetterie S.p.A. non fornisce garanzie circa l'impiego errato o inadatto dei propri prodotti. Qualora il materiale risultasse difettoso per vizi di fabbricazione riconosciuti a seguito di perizia, la Remer Rubinetterie S.p.A. si riserva di sostituirlo o accreditarne il valore senza che la propria responsabilità si possa estendere in nessun caso ad altri oneri.

Foro

Per qualsiasi controversia il Foro competente è quello di Milano.

Stampato nel mese di Febbraio 2025.

Sale conditions

Orders acceptance

The order is always subject to approval by the seller.

Delivers

The goods are delivered Ex Works and travel at the buyer's own risk. The seller reserves the right to execute partial consignments.

Forwarding

The quantities must be checked on receipt of the goods and any complaint must be made to the carrier. Any additional cost applied by the carrier will be charged to the buyer.

Packing

The goods are packed in standard packing on pallets charged to the customer.

Delivery terms

The delivery terms are always given as information and they never have to be considered as binding.

Prices

The prices shown on price list are not binding. Remer Rubinetterie S.p.A. reserves the right to modify the sales prices in any time with no prior warning.

Payments

Interest at the current rate will be charged for any delays in payment. Remer Rubinetterie S.p.A. reserves the right to delete any order on hand if the payments are not correct. Any complaint of whatever type or value do not give the right to suspend payments.

Complaints

Complaints and returned goods cannot be accepted after a period of 7 days from the arrival of the goods. Complaints must be made by mean of a registered letter or by fax within the terms stated. Any return of the goods must be authorized in advance by Remer Rubinetterie S.p.A. with instructions about it.

Technical specifications

Remer Rubinetterie S.p.A. reserves the right to carry out technical and aesthetical changes without previous notice to customers.

Lien

The products remain the property of Remer Rubinetterie S.p.A. until the cost has been paid in full, in accordance with the provisions of the C.C.

Liability

Remer Rubinetterie S.p.A. does not provide a guarantee covering the incorrect or the inappropriate use of its products. If the material should be substandard owing to manufacturing faults which are technical inspections, Remer Rubinetterie S.p.A. reserves the right to replace the material or to credit the value to the buyer. However under no circumstance does the company's liability extend to the payment of direct or indirect charges for other things.

Competent Court of Law

For any controversy that may arise the competent court of law is the one of Milan.

Printed on February 2025.

REMER
RUBINETTERIE



Ufficio Commerciale Italia:

Tel. 0363 364 333
Fax 0363 63 575

Remer Rubinetterie S.p.A.

Via Leonardo da Vinci, 83
20062 Cassano d'Adda (MI) Italy
Tel. +39 0363 364 211
info@remer.eu www.remer.eu

Export Commercial Department:

Tel. +39 0363 364 364
Fax +39 0363 364 300